



Thank You for purchasing this

Factory Service Manual on EBAY

from PCTECHINFO!



[Click Here](#) for more Factory Service

Manuals for other Computer and

Printer / Copier Manufacturers

from PCTECHINFO!



Oki Data

Service Guide



OKIPAGE 18 and 18n

Adobe Acrobat printable reference copy
of the OKIDATA Service Training Manual.
01/26/2000

Note: This Adobe Acrobat version of the Okidata Service Training Manual was built with the pictures rendered at 300 dpi, which is ideal for printing, but does not display well on most displays.

Service Guide OKIPAGE 18/18n**0 Introduction**

Preface	1
---------	---

1 Configuration

Configuration	2
....1.1 System Configuration	3
....1.2 Printer Configuration	4
....1.3 Optional Configuration	5
....1.4 Specification	6
....1.5 Safety Standards	7
.....1.5.1 Certification Label	8
.....1.5.2 Warning Label	9

2 Operation Description

2.0 Operation Description	10
2.1 Main Control Board (BOARD-FFF)	11
2.2 Power Supply Unit	12
2.3 Electro-photographic Process	13
....2.3.1 Electro-photographic process mechanism	14
....2.3.2 Electro-Photographic process	15
....2.3.3 Process operation descriptions	16
....2.3.4 Revision of LED Head Illumination	17
2.4 Paper Jam Detection	18
2.5 Cover Open	19
2.6 Toner Low Detection	20
2.7 Stacker-full Detection	21
2.8 Page Size Detection	22

3 Parts Replacement

Parts Replacements	23
....3.1 Precautions for Parts Replacement	24
....3.2 Parts Layout	25
.....Figure 3-1	26
.....Figure 3-2	27
.....Figure 3-3	28
....3.3 How to Change Parts	29
.....3.3.1 Face-up Stacker Assy	30
.....3.3.2 Contact Assy	31
.....3.3.3 DC Fan Motor	32
.....3.3.4 OP Panel Assy	33
.....3.3.5 Board - FFF	34
.....3.3.6 Stacker Assy, Damper Arm, Cover Rear	35
.....3.3.7 Sensor Stacker Full	36
.....3.3.8 Cable cover (guide film)	37
.....3.3.9 Damper	38
.....3.3.10 Feeder Unit - Front	39
.....3.3.11 Roller Assy - Regist	40
.....3.3.12 Motor - Main	41
.....3.3.13 Guide Assy - Eject	42
.....3.3.14 Heat Assy	43
.....3.3.15 Roller feed (C)	44
.....3.3.16 Roller Assy - BK	45
.....3.3.17 Roller Assy - Feed	46

Table of Contents

Page

.....3.3.18 LED Head	47
.....3.3.19 Paper cassette, ROLLER Assy - Feed, ROLLER Assy - Hopping	48
.....3.3.20 Frame Assy - Separation	49
.....3.3.21 Transfer Roller / TR Gear / TR Bearing	50
.....3.3.22 EP lock shaft	51
.....3.3.23 LEVER Assy - Out Sensor	52
.....3.3.24 Toner sensor lever	53
.....3.3.25 Paper sensor lever	54
.....3.3.26 Inlet sensor lever	55
.....3.3.27 Power supply unit	56
.....3.3.28 Lever-Paper end & Lever-Paper near end	57
.....3.3.29 Guide Assy - Cassette (L)	58
.....3.3.30 Guide Assy - Cassette (R)	59
4 Adjustment	
4.0 Adjustment	60
....4.1 Maintenance Modes and Functions	61
.....4.1.1 User maintenance mode	62
.....4.1.2 System maintenance mode	63
.....4.1.3 Engine maintenance mode	64
.....4.1.4 EEPROM initialization	65
....4.2 Adjustment When Replacing a Part	66
.....4.2.1 Setting LED Head Drive Time	67
.....4.2.2 Destination setting	68
.....4.2.3 Setting of LED head drive time	69
5 Periodical Maintenance	
5.1 Periodic Maintenance	70
5.2 Cleaning	71
....5.2.1 Cleaning the LED Lens Array	72
....5.2.2 Cleaning the Plastic Film	73
6 Troubleshooting Procedures	
6.1 Troubleshooting Tips	74
6.2 Check Points Before Correcting Image Problems	75
6.3 Notes When Correcting Image Problems	76
6.4 Preparation Before Troubleshooting	77
6.5 Troubleshooting Flowchart	78
....6.5.1 Status Monitor Message List	79
....6.5.2 LCD message troubleshooting	80
.....(1) The printer does not work normally after being turned on.	81
.....(2) Paper jams	82
.....(2)-1 Paper input jam (1st tray)	83
.....(2)-2 Paper input jam (front feeder)	84
.....(2)-3 Paper feed jam	85
.....(2)-4 Paper exit jam	86
.....(3) Paper size error	87
.....(4) Fuser unit error (ERROR 71), (ERROR 72), (ERROR 73)	88
.....(5) I/F time-out between printer and optional tray (ERROR 81)	89
.....(6) I/F time-out between printer and Duplex Unit (ERROR 83)	90

Table of Contents	Page
--------------------------	-------------

.....(7) I/F time-out occurs between the printer and the operator panel (ERROR 80)	91
.....(8) Message cannot be received through the parallel interface	92
.....(9) Message cannot be received through the serial interface	93
.....(10) Data cannot be received through the OKI HSP interface	94
.....(11) Synchronous serial I/O error (ERROR 74)	95
....6.5.3 Image Troubleshooting	96
.....(1) An image is light or blurred entirely	97
.....(2) Dark background density	98
.....(3) Black paper is output	99
.....(4) Black belts or stripes in the vertical direction	100
.....(5) Cyclic error	101
.....(6) Print voids	102
.....(7) Poor fusing	103
.....(8) White belts or streaks in the vertical direction	104
.....(9) Snowy print of high density pattern	105
.....(10) Blotchy faded print	106
.....Contents - Figure 6-5	107
.....Contents - Figure 6-6	108
7 Wiring Diagram	
7.1 Interconnect Signal Diagram	109
7.2 PCB Layout	110
....7.2.1 Main Control Board (HBY PCB)	111
....7.2.2 Power Supply Board (120V/230V)	112
....7.2.3 Power supply board (High voltage)	113
....7.2.4 Flash ROM module (BOARD-FSL or BOARD-FSL-2)	114
7.3 Resistance Check	115
7.4 Program Font/ROM Location	116
8 Parts List	
Figure 8-1 Printer Unit	117
Figure 8-2 Frame - Main Unit	118
Figure 8-3 Base Unit	119
A Centronics Parallel Interface	
Parallel Interface	120
B RS-232C Serial Interface	
RS-232C Serial Interface	121
C Duplex Unit Maintenance (option)	
1. OUTLINE	122
....1.1 Functions	123
....1.2 External View and Component Names	124
2.0 Mechanism Description	125
....2.1 General Mechanism	126
....2.2 JAM Release Mechanism	127
....2.3 Removing/Installing Duplex Unit	128
3.0 Parts Replacement	129
....3.1 Precautions Concerning Parts Replacement	130
....3.2 Parts Layout	131
....3.3 Parts Replacement Methods	132

Table of Contents

Page

.....3.3.1 Board-LEX	133
.....3.3.2 Connector (IMSA-9714N-14A)	134
.....3.3.3 Photo Sensor	135
.....3.3.4 SOLENOID Assy	136
.....3.3.5 Motor	137
4.0 Troubleshooting	138
....4.1 Precautions Prior to the Troubleshooting	139
....4.2 Preparations for the Troubleshooting	140
....4.3 Troubleshooting Method	141
.....4.3.1 LCD Status Message List	142
.....4.3.2 Troubleshooting Flow	143
5.0 Connection Diagram	144
....5.1 Interconnection Diagram	145
....5.2 PCB Layout	146
6.0 Parts List	147
Table 6-1 Duplex Unit	148
D Second / Third Paper Feeder Maint (option)	
1.0 Outline	149
....1.1 Functions	150
....Appearance and Parts Name	151
2.0 Description of operation	152
....2.1 Driving Mechanism	153
....2.2 Hopper Mechanism	154
3.0 Parts Replacement	155
....3.1 Precautions Concerning Parts Replacement	156
....3.2 Parts Layout	157
....3.3 Parts Replacement Methods	158
.....3.3.1 Roller assy hopping, Roller assy feed	159
.....3.3.2 Cover front assy	160
.....3.3.3 Board-BBB	161
.....3.3.4 Lever paper end, Lever paper near end	162
.....3.3.5 Motor	163
.....3.3.6 Connector (IMSA-9714N-14B), Connector (IMSA-9714N-14A)	164
.....3.3.7 Frange pulley, pulley Idle, Mini pitch belt, Plate Earth shaft, Gear double, Tray switch assy	165
.....3.3.8 Roller feed	166
.....3.3.9 Bracket sub roller	167
.....3.3.10 Frame side (L) assy	168
.....3.3.11 Frame side (R) assy	169
4.0 Troubleshooting	170
....4.1 Precautions Prior to the Troubleshooting	171
....4.2 Preparations for the Troubleshooting	172
....4.3 Troubleshooting Method	173
.....4.3.1 LCD Status Message List	174
.....4.3.2 Troubleshooting Flow	175
5.0 Connection Diagram	176
....5.1 Interconnection Diagram	177
....5.2 PCB Layout	178
6.0 Parts List	179
E Multi-Purpose Feeder Maintenance	

Table of Contents	Page
1.0 Outline	180
....1.1 Functions	181
....1.2 External View and Component Names	182
2.0 Mechanism Description	183
....2.1 General Mechanism	184
....2.2 Hopper Mechanism	185
3.0 Parts Replacement	186
....3.1 Precautions Concerning Parts Replacement	187
....3.2 Parts Layout	188
....3.3 Parts Replacement Methods	189
.....3.3.1 Separator	190
.....3.3.2 AOLE-PCB	191
.....3.3.3 Square-shaped connector	192
.....3.3.4 Hopping Motor	193
.....3.3.5 Planet gear	194
.....3.3.6 Roller B	195
.....3.3.7 Roller A	196
.....3.3.8 Mini pitch belt & Feed roller	197
4.0 Troubleshooting	198
....4.1 Precautions Prior to the Troubleshooting	199
....4.2 Preparations for the Troubleshooting	200
....4.3 Troubleshooting Method	201
.....4.3.1 LCD Status Message List	202
.....4.3.2 Troubleshooting Flow	203
5.0 Connection Diagram	204
....5.1 Interconnection Diagram	205
....5.2 PCB Layout	206
6.0 Parts List	207



Service Guide OKIPAGE 18/18n Chapter 0 Introduction

Page: 1

Preface

This maintenance manual describes the field maintenance methods for OKIPAGE 18.

This manual is written for use by maintenance personnel. Note, however, that the user should refer to the USER'S MANUAL for methods of handling and operating the equipment.

Copyright 1998, Okidata, Division of OKI America, Inc. All rights reserved. See the OKIDATA Business Partner Exchange (BPX) for any updates to this material. (<http://bpx.okidata.com>)



Service Guide OKIPAGE 18/18n Chapter 1 Configuration

Page: 2

Configuration

System Configuration

Printer Configuration

Optional Configuration

Specification

Safety Standards

Copyright 1998, Okidata, Division of OKI America, Inc. All rights reserved. See the OKIDATA Business Partner Exchange (BPX) for any updates to this material. (<http://bpx.okidata.com>)



1.1 System Configuration

The OKIPAGE 18 consists of control and engine blocks as the standard configuration (See Figure 1-1).

In addition, the following options are also available.

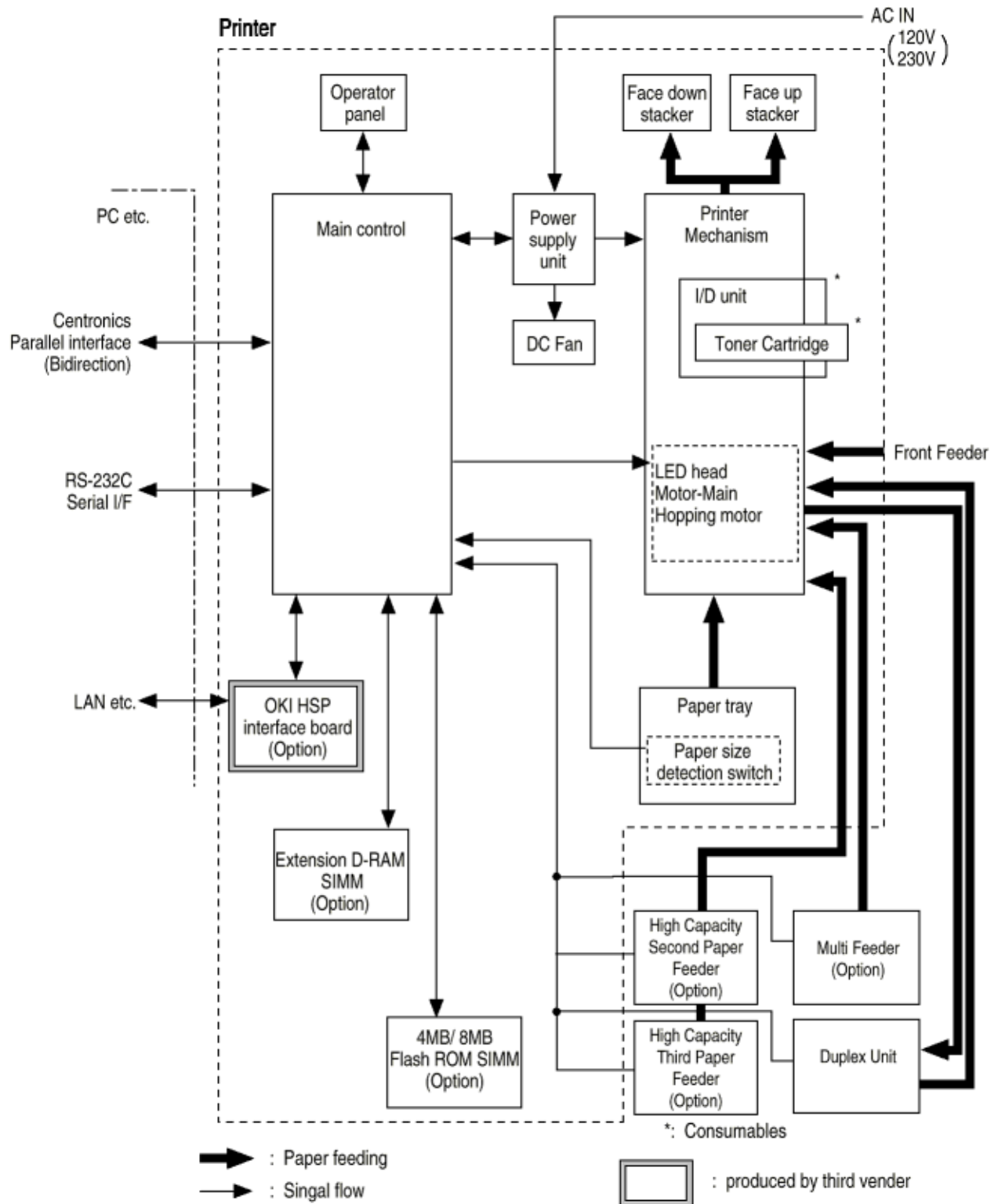

Figure 1-1

Figure 1-1

Copyright 1998, Okidata, Division of OKI America, Inc. All rights reserved. See the OKIDATA Business Partner Exchange (BPX) for any updates to this material. (<http://bpx.okidata.com>)



1.2 Printer Configuration

The printer unit consists of the following hardware components:

- Electro-Photographic Processor
- Paper Feeder
- Controller
- Operator panel
- Power supply unit

Figure 1-2 is the configuration of the printer unit.

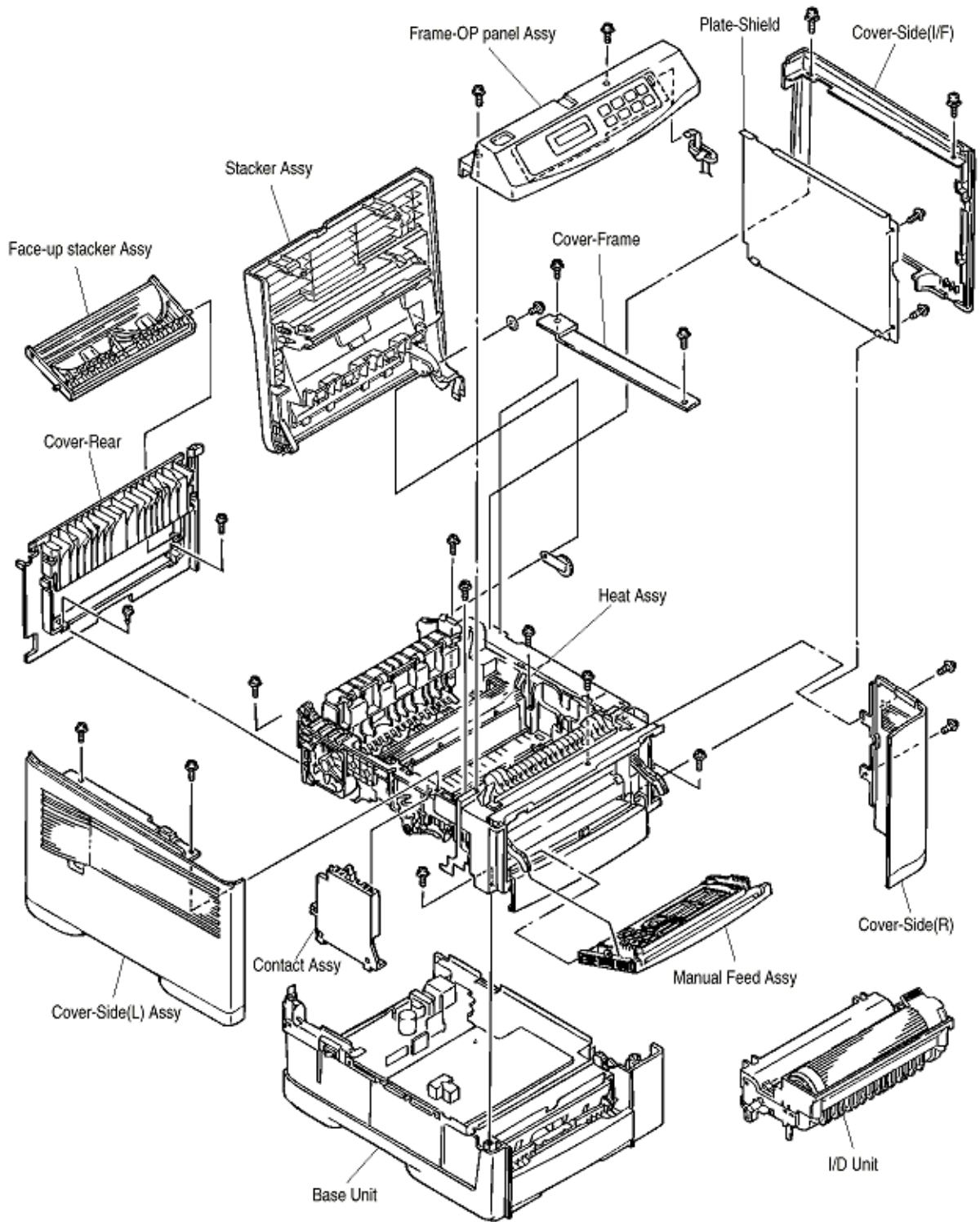
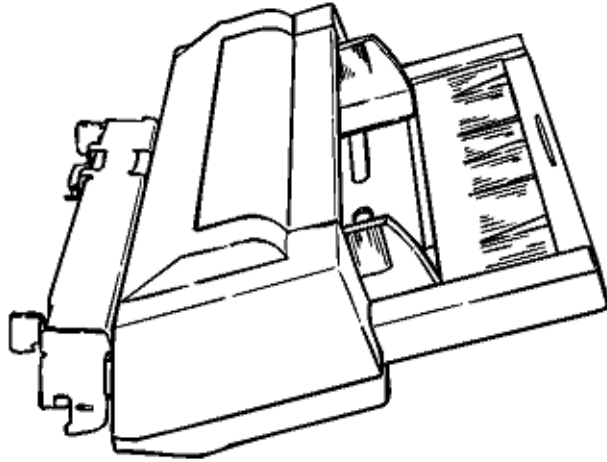
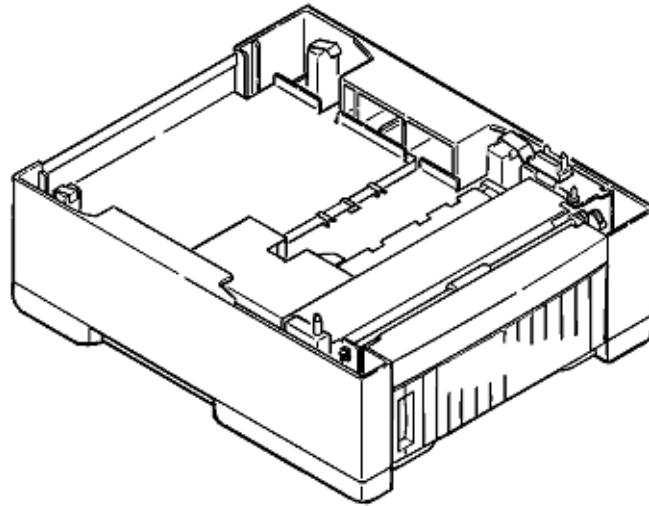
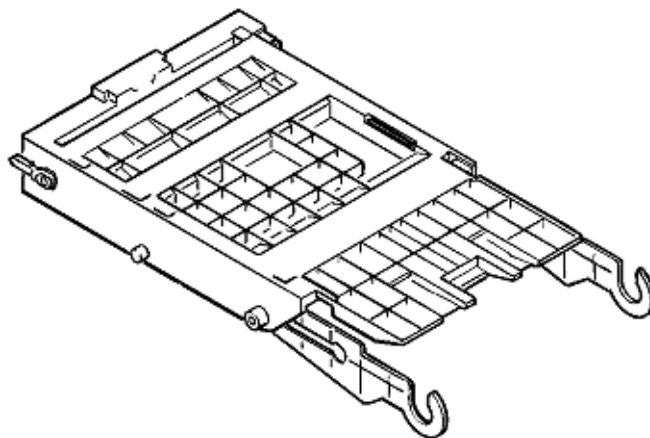
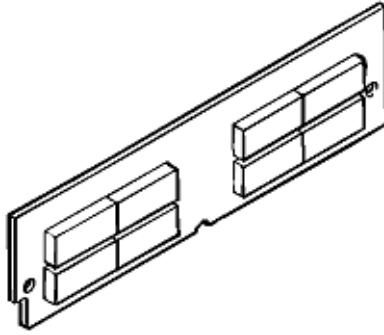

Figure 1-2

1.3 Optional Configuration**1 Multi Feeder****2 Second / Third Paper Feeder****3 DUPLEX Unit (Optional)**

- 4 D-RAM SIMM module (72 pin SIMM, 16 MB/32MB, EDO SIMM type) (See 7.2 (1) for where to install).



- 5 Flash ROM module (72 pin SIMM, 4MB/8MB) (See 7.2 (1) for where to install).

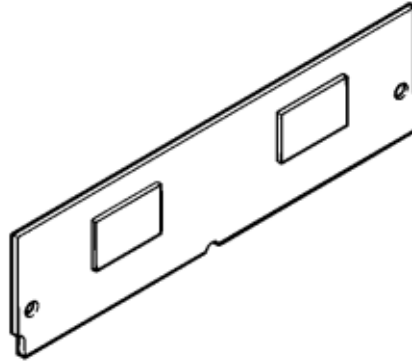



1.4 Specification

- | | |
|--|--|
| (1) Type: | Desktop |
| (2) Outside dimensions
(excludes protruding
portion) | Height: 13.0" (331 mm)
Width: 14.4" (366 mm)
Depth: 18.2" (462 mm) |
| (3) Weight | 42 lbs. (19.0 kg)
If installed Duplex 47 lbs. (21.3 kg) |
| (4) Development method
Exposure method | Dry electrophotography
LED stationary head |
| (5) Paper used | <Type> <ul style="list-style-type: none">● Standard paper- Xerox 4200 (20 lbs)● Application paper (manual face-up feed)- Label- Envelope- OHP paper (Transparency) <Size> <ul style="list-style-type: none">● Standard sizes- Letter- Legal- Executive- Envelope (with Duplex printing)- A4- A5 (without Duplex printing)- B5 (without Duplex printing)- A6 (without Duplex printing)● Applicable sizes-Width: 3.4" to 8.5" (86 to 216 mm)- Length: 5.5" to 14" (140 to 355.6 mm) <Thickness> <p>Automatic feed: 16 to 28 lbs (60 to 105 g/m²)</p> <p>- Manual feed: Label, OHP paper (transparency), Envelope, 16~36 lb.</p> |
| (6) Printing speed: | First print: 8 seconds
Continuous print: 8 sheets/min. [at duplex print: 9 sheets/min]
Warm-up time: 90 seconds (at room temperature 77° F (25° C) and rated voltage (120 VAC) |
| (7) Paper feeding method | Automatic feed or manual feed |

- (8) Paper delivery method Face down/face up
- (9) Resolution 600 dpi x 600 dpi (default)
600 x 1200 dots/inch
- (10) Power input 120 VAC +/-15%
230 VAC +/-10%
- (11) Power consumption Peak: Approx. 820W
Typical operation: Approx. 350W
Idle: Approx. 95W
Power save mode: Approx. 25W
- (12) Temperature and humidity

	In operation	Power off mode	During Storage	Unit
Temperature	50 - 90 (10-32)	32-110 (0-43)	14-110 (-10 - 43)	° F (°C)
Humidity	20 - 80	10-90	10-90	% RH
Maximum wet bulb temperature	77 (25)	80.4 (26.8)	-----	° F (°C)
Minimum difference of wet and dry bulb temperature	35.6 (2)	35.6 (2)	-----	° F (°C)

Notes:

1. Storage conditions specified above apply to printers in packed condition.
2. Temperature and humidity must be in the range where no condensation occurs.

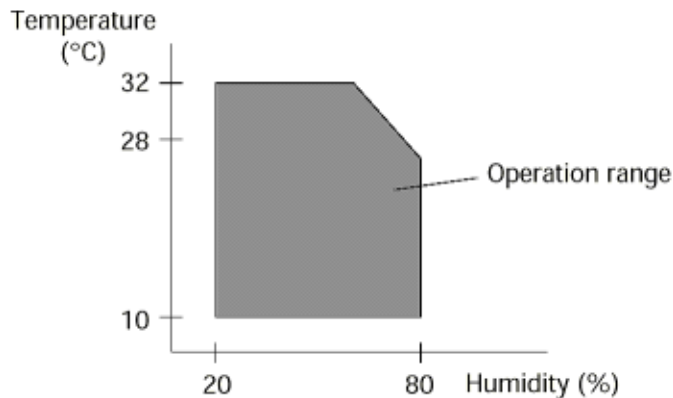

- (13) Noise During operation: 52 dBA or less (without second tray)
52 dBA or less (with second tray)
At standby: 45 dBA or less
Power save mode: 43 dBA or less
 - (14) Consumables Toner cartridge kit - 6,000 (5% duty)
Image drum cartridge - 30,000 (at 5% density, continuous printing)
-

Copyright 1998, Okidata, Division of OKI America, Inc. All rights reserved. See the OKIDATA Business Partner Exchange (BPX) for any updates to this material. (<http://bpx.okidata.com>)



Service Guide OKIPAGE 18/18n Chapter 1 Configuration

Page: 7

1.5 Safety Standards

1.5.1 Certification Label

1.5.2 Warning Label

Copyright 1998, Okidata, Division of OKI America, Inc. All rights reserved. See the OKIDATA Business Partner Exchange (BPX) for any updates to this material. (<http://bpx.okidata.com>)



Service Guide OKIPAGE 18/18n Chapter 1 Configuration

1.5.1 Certification Label

The safety certification label is affixed to the printer in the position below.

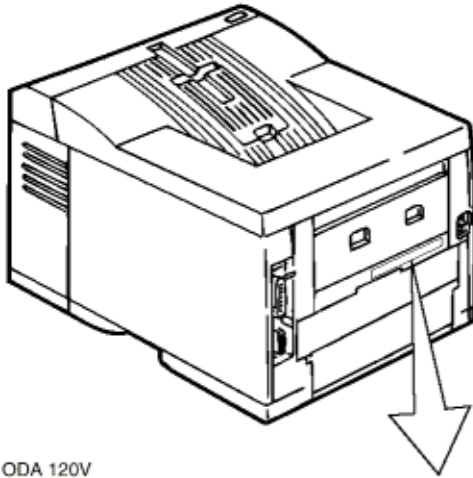

ex. ODA 120V

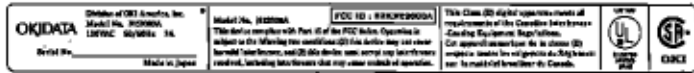

Service Guide OKIPAGE 18/18n Chapter 1 Configuration

1.5.2 Warning Label

The warning label is affixed to the portion which may cause an injury to human body. Follow the instructions on warning labels during maintenance.

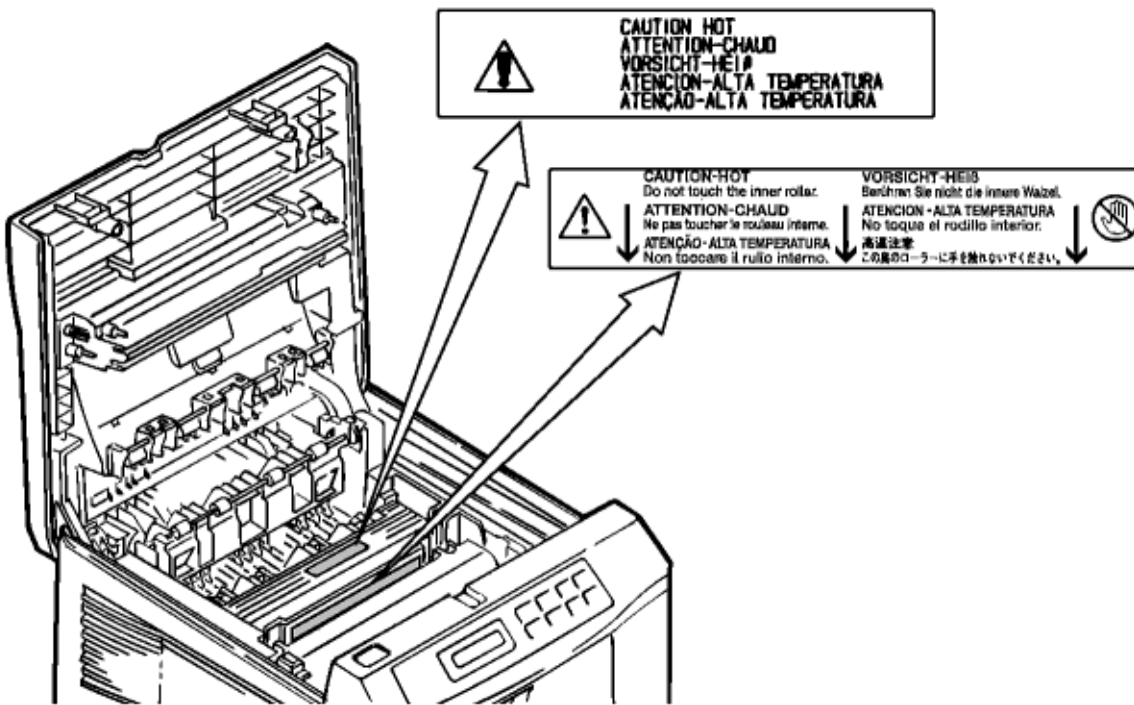



Service Guide OKIPAGE 18/18n

Chapter 2 Operation Description

2.0 Operation Description

OKIPAGE 18 consists of a main control board, power supply unit (120V/230V), power supply unit (high voltage) and operator panel and an electro-photographic process mechanism.

The control board receives data through a host I/F, decodes and edits the data, and stores the edited data in a memory. After completing edition of one page of data, it references the font memory and generates bit data on the same memory. At the same time, it transfers the bit image data to an LED head in units of one dot line.

The electro-photographic process mechanism prints data on paper.

The operator panel is used for operations and status display.

Fig. 2-1 shows an OKIPAGE18 block diagram.

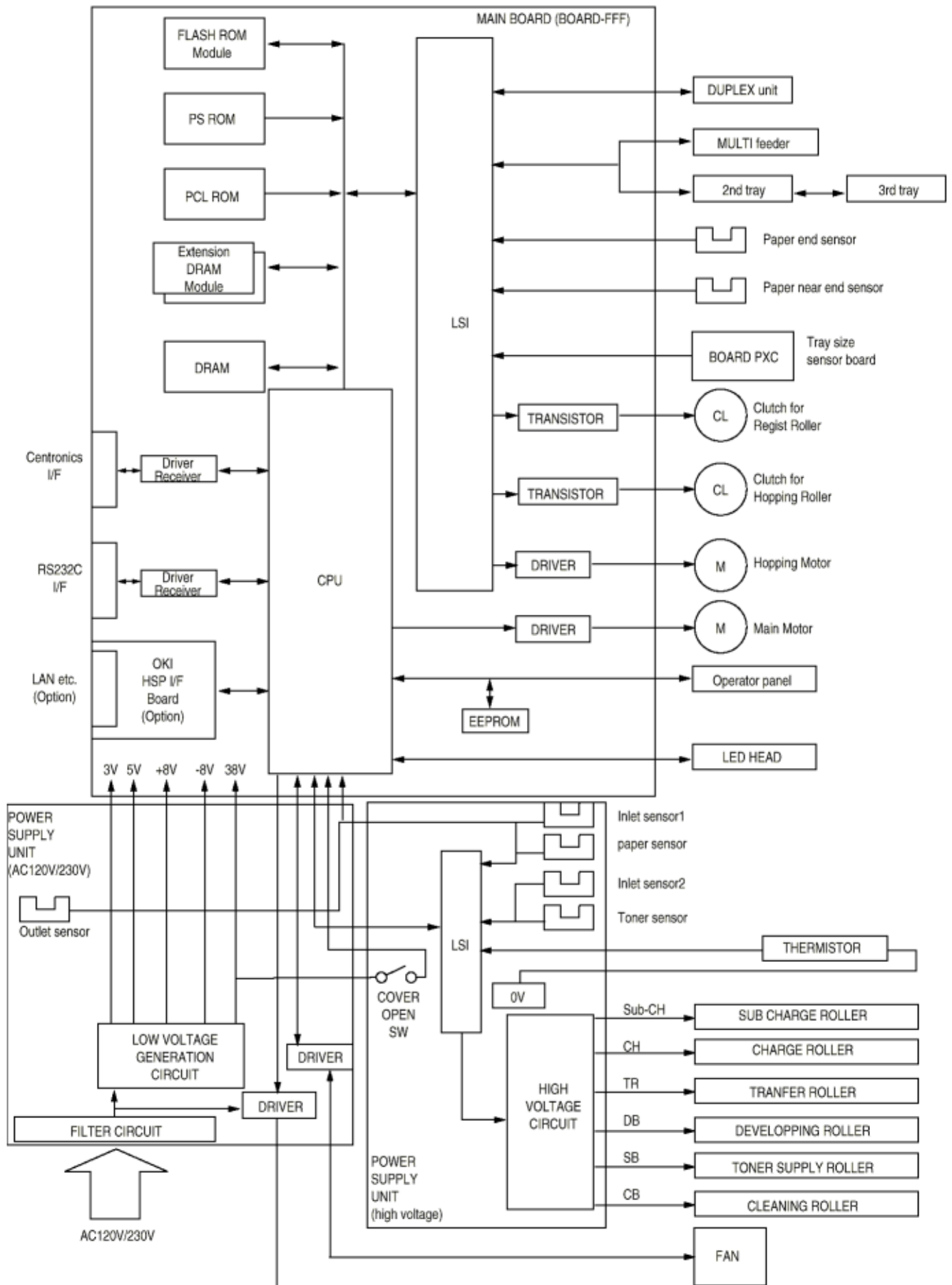

Figure 2-1 OKIPAGE 18 block diagram

Copyright 1998, Okidata, Division of OKI America, Inc. All rights reserved. See the OKIDATA Business Partner Exchange (BPX) for any updates to this material. (<http://bpx.okidata.com>)

Service Guide OKIPAGE 18/18n

Chapter 2 Operation Description

2.1 Main Control Board (BOARD-FFF)

The main control board consists of a one-chip CPU, LSI, program/font ROM's, DRAM's, EEPROM, host interface circuit, and a mechanism driving circuit.

(1) One-chip CPU

The one-chip CPU is a custom CPU (32-bit internal bus, 32-bit external bus, 120-MHz clock) that incorporates an RISC CPU and its peripheral devices, and has the following functions.

Built-in Device	Function
Chip select controller Bus controller DRAM controller	Control peripheral LSI, ROM, DRAM and I/O device.
DMA controller	Transfer of data Host I/F to RAM
Serial interface controller	Control of RS232C serial interface.
Parallel interface controller	Control of Centronics parallel interface.
Timer	Generates various control timings for monitoring paper feeding and a paper size.
Serial I/O port	Inputting of various signals Outputting of various control signals
I/O port	Inputs and outputs the sensor signals and motor signals, etc. Also performs I/O for EEPROM.
Motor driver controller	Control of Main Motor.
Image processing circuit	Executes the image data process for printing.

(2) Program/font ROM's

- PCL ROM
The program/font ROM's store the HP LJ5 emulation program and various types of font. MASK ROM is used as the program/font ROM's.
- PS ROM
The program/font ROM's store the Adobe PostScript Level 2 program and its fonts.

(3) DRAM

16-Megabyte DRAM (64 Mbit DRAM x 2) is mounted as resident memory to be used for storing the program and providing various buffers. This DRAM is expandable up to 128 Mbytes by adding expansion memory (SIMMs). This DRAM provides the areas shown in the following table.

Memory area	Use	Memory capacity setting	
		MENU	Expansion RAM
System area	Working area used for the program	Fixed	Fixed
Raster buffer	Stores converted bit image data	Enable	Expandable
Receive buffer	Stores temporarily the data received from the host interface	Enable	Expandable
Page buffer	Adds print information to the analyzed receive data and stored the resulted data.	----	Expandable
DLL/macro buffer	Stores soft fonts and macro data.	----	Expandable
Font cache buffer	Stores bit map fonts generated by the font rasterizer based on scalable font information.	Enable	Expandable

(4) EEPROM

EEPROM has a 16-kbit capacity and stores the following data.

- Menu data
- Various counter data (page counter, drum counter, fuser counter, etc.)
- Adjustment parameters (LED head drive time, print start position, etc.)

(5) LSI (LZ9FF22)

Built in device	Function
Serial I/O port	Control of serial interface between controller and 2nd tray, 3rd tray, Multi purpose feeder Control of serial interface between controller and Duplex unit
Motor drive controller	Control of Hopping motor
I/O Port	Inputting of various sensor signals Outputting if various control signals

(6) Host interface

This printer has the following interfaces to the host.

- Centronics bidirectional parallel interface
- RS232C interface
- OKI HSP interface (Option)

The single effective interface or the automatic interface select mode can be selected using the menu. If the busy state of the printer continues for a long time period, the buffer near-full control releases the busy status at constant intervals even if the host side is busy so not to cause the interface time-out at the host side.

(a) Centronics bidirectional parallel interface

This is an interface conforming to IEEE-1284 and provides either of unidirectional and bidirectional communications according to each of the following communication modes.

- Compatibility mode
Unidirectional communications from the host to the printer.
- Nibble mode

This mode transmits 4-bit wide data from the printer to the host. In this mode, each 1-byte data is transferred in the form of two nibbles using ERROR, BUSY, FAULT, and SELECT signal leads. This mode can provide the bidirectional operation in combination with the compatibility mode.

- ECP mode
This mode provides the asynchronous bidirectional interface and transmits and receives 1-byte data using eight data signal leads under the semi-duplex control by the host.

When the power is turned on, the compatibility mode is automatically selected. The change to another mode from the compatibility mode is made through negotiation. (When the BI DIRECTION is set to ENABLE in the menu, this change can be performed.) (For the electrical/physical characteristics of this interface, see APPENDIX B)

(b) RS232C serial interface

The following protocol is supported for the serial interface conforming to EIA RS232C.

- READY/BUSY (DTR HI or DTR LO)
- X-ON/X-OFF
- RBST X-ON

(For the electrical/ physical characteristics of the interface, see APPENDIX B)

(c) OKI HSP interface (Option)

This interface (slot) is an OKI unique universal interface that provides the platform to connect option boards (including those supplied by third party vendors) such as the LAN connection expansion board and SCSI expansion board.

Any expansion boards compatible with this interface can be mounted on the Control board in the piggyback board without modifying the program at the printer side. The conceptual diagram of the OKI HSP interface is shown in Figure 2-2.

(For the electrical/physical characteristics of the OKI HSP interface, see the OKI HSP interface technical manual.)

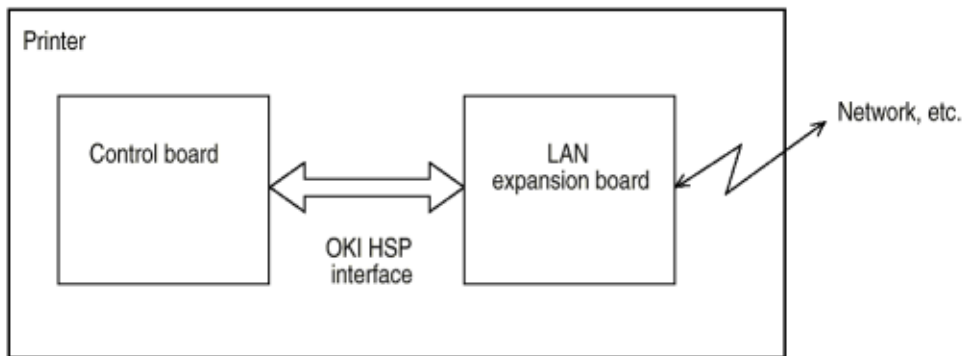
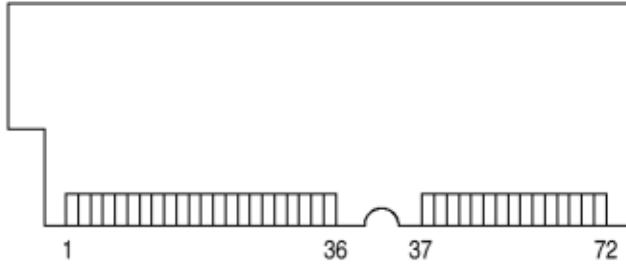

Figure 2-2

(7) RAM module

- Pin layout



- Basic specification

- Type: 72 pins Standard SIMM (32 bits buss width)
[Note: EDO SIMM type]
- Access time: 60ns, 70ns, 80ns, 100ns
- Capacity: 16 or 32 MB
- Parity: None

(8) Flash ROM module

- Pin layout

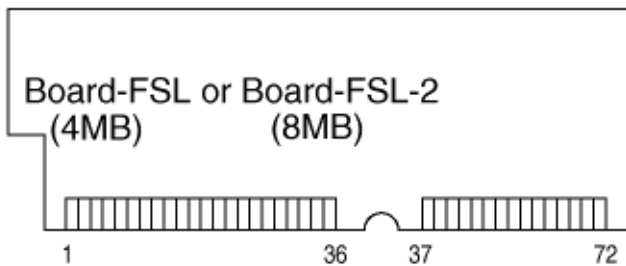

- Basic specification

- Type: 72 pins SIMM (32 bits buss width)
- Access time: 90ns
- Capacity: 4 or 8 MB

Service Guide OKIPAGE 18/18n

Chapter 2 Operation Description

2.2 Power Supply Unit

The power supply unit consists of an AC filter circuit, a low voltage power supply circuit, a high voltage power supply circuit, heater drive circuit, and photosensors.

(1) Low voltage power supply circuit

This circuit generates the following voltages.

Output voltage	Use
+5 V	Logic circuit supply voltage
+30 V	Motor and fan drive voltage and source voltage for high-voltage supply
+8 V	Reset circuit, RS232C Line voltage
-8 V	RS232C Line voltage
+3.8 V	LED HEAD supply voltage

(2) High voltage power supply circuit

This circuit generates the following voltages necessary for electro-photographic processing from +30 V according to the control sequence from the control board. When cover open state is detected, +30 V supply is automatically interrupted to stop the supply of all the high-voltage outputs.

Output	Voltage	Use	Remarks
Sub-CH	-15 uA	Voltage applied to Sub charging roller	
CH	-1.30 KV	Voltage applied to charging roller	
DB	-220 V+300 V	Voltage applied to developing roller	
SB	-450 V	Voltage applied to toner supply roller	
TR	+4 KV/-1.3 kV	Voltage applied to transfer roller	Variable + Only
CB	+450 V-1350V	Voltage applied to cleaning roller	

(3) Photosensor

The photosensor mounted on this power supply unit supervises the paper running state during printing.

Figure 2-3 shows the sensor layout diagram.

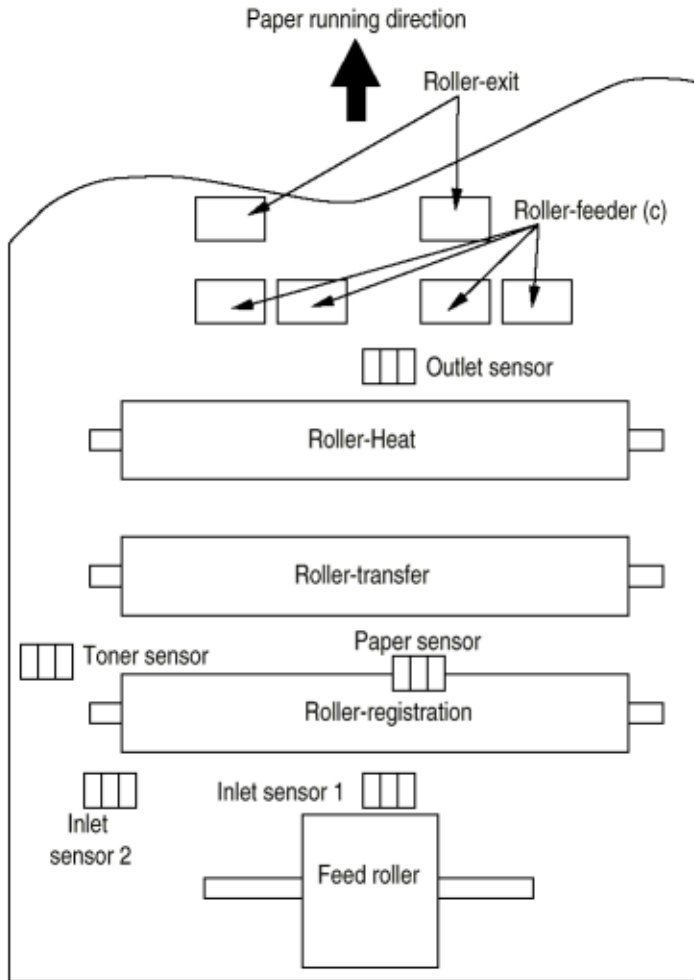

Figure 2-3

Sensor	Function	Sensing state
Inlet sensor	Detects the leading part of the paper and gives the supervision timing for switching from hopping operation to feeding operation. Supervises the paper running state and the paper size according to the paper reach time and running time.	ON: Paper exists OFF: No paper exists
Inlet sensor 2	Detects the form width.	ON: A4 or larger OFF: A4 or smaller
Paper sensor	Detects the leading part of the paper. Supervises the paper running state.	ON: Paper exists OFF: NO paper exists
Outlet sensor	Supervises the paper feed and size according to the time of arrival to the sensor and the time of passage of paper.	ON: Paper exists OFF: No paper exists
Toner low sensor	Detects the lack of toner.	ON long: Toner low exists OFF short: No Toner low exists

Copyright 1998, Okidata, Division of OKI America, Inc. All rights reserved. See the OKIDATA Business Partner Exchange (BPX) for any updates to this material. (<http://bpx.okidata.com>)



2.3 Electro-photographic Process

2.3.1 Electro-photographic process mechanism

2.3.2 Electro-photographic process

2.3.3 Process operation descriptions

2.3.4 Revision of LED Head Illumination

Copyright 1998, Okidata, Division of OKI America, Inc. All rights reserved. See the OKIDATA Business Partner Exchange (BPX) for any updates to this material. (<http://bpx.okidata.com>)

2.3.1 Electro-photographic process mechanism

This mechanism prints image data from the control board on the paper by electro-photographic process.

The Figure 2-4 shows the layout of the electro-photographic process mechanism.

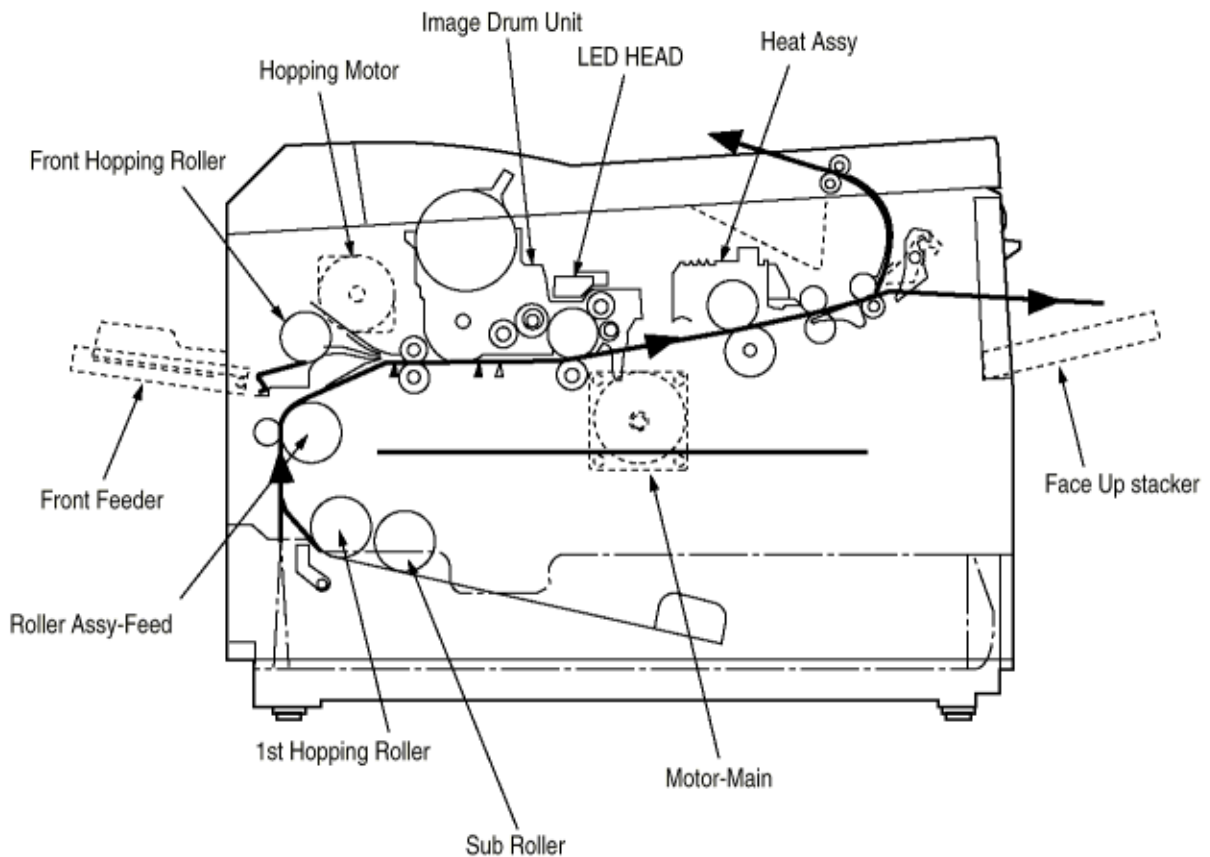

Figure 2-4

(1) Image drum unit

The image drum unit consists of a sensitive drum, a charger, and a developer. The unit forms a toner image on the sensitive drum, using a electrostatic latent image formed by the LED head.

(2) Hopping motor

This motor is a pulse motor of 48 steps/rotation that is two-phase excited by the signal from the control board. It drives the hopping roller of the first tray and the front feed roller via two one-way clutches according to the direction of rotation.

(3) Motor-Main

This motor is a pulse motor of 72 steps/rotation that is two-phase excited by the signal from the control board and is the main motor of this mechanism.

(4) Clutch (for Registration)

Switches the transfer of power to Roller Registration if necessary depending on the power Motor-Main and instructions from the control PCB.

(5) Clutch (for Feed Roller)

Switches the transfer of power to Feed Roller if necessary depending on the power from Motor-Main and instructions from the control PCB.

(6) LED head

Image data for each dot line from the control board is received by the shift register and latch register. The 4992 LEDs are driven to radiate the image data to the image drum.

(7) Fuser

The fuser consists of a heater, a heat roller, a thermistor and a thermostat. An AC voltage from the power supply board is applied to the heater under the control of the HEATON signal from the control board. This AC voltage heats the heater. The control board supervises the heat roller temperature via the thermistor, and regulates the heater roller at a predetermined temperature (185 °C : Normal paper, MEDIA TYPE = MEDIUM) by connecting or disconnecting the AC voltage supply to the heater. If the heater roller temperature rises abnormally, the thermostat of the heater voltage supply circuit is activated to cut the AC voltage supply forcibly.

2.3.2 Electro-Photographic process

The electro-photographic processing is outlined below. Figure 2-5 shows the electro-photographic printing process.

1 Charging

The surface of the image drum is uniformly charged with negative charges by applying a negative voltage to the charge roller.

2 Exposure

Light emitted from the LED head irradiates the negatively charged surface of the image drum. The surface potential of the irradiated part of the image drum surface is lowered, so that an electrostatic latent image associated with the print image is formed.

3 Developing and toner recovery

When the negatively charged toner is brought into contact with the image drum, it is attracted to the electrostatic latent image by static electricity, making the image visible. At the same time, the residual toner on the image drum is attracted to the developing roller by static electricity.

4 Transfer

When paper is placed over the image drum surface and a positive charge, opposite in polarity to the toner, is applied to the reverse side of the paper from the transfer roller, the toner is attracted by the positive charge and is transferred to the paper. As a result, the toner image formed on the image drum is transferred to the paper.

5 Temporary cleaning

Residual toner that remains on the image drum without being transferred is made uniform by the cleaning roller and is temporarily attracted to the cleaning roller by static electricity.

6 Fusing

The toner image transferred to the paper is fused under heat and pressure. Figure 2-6 shows an electro-photographic process timing chart.

Figure 2-7

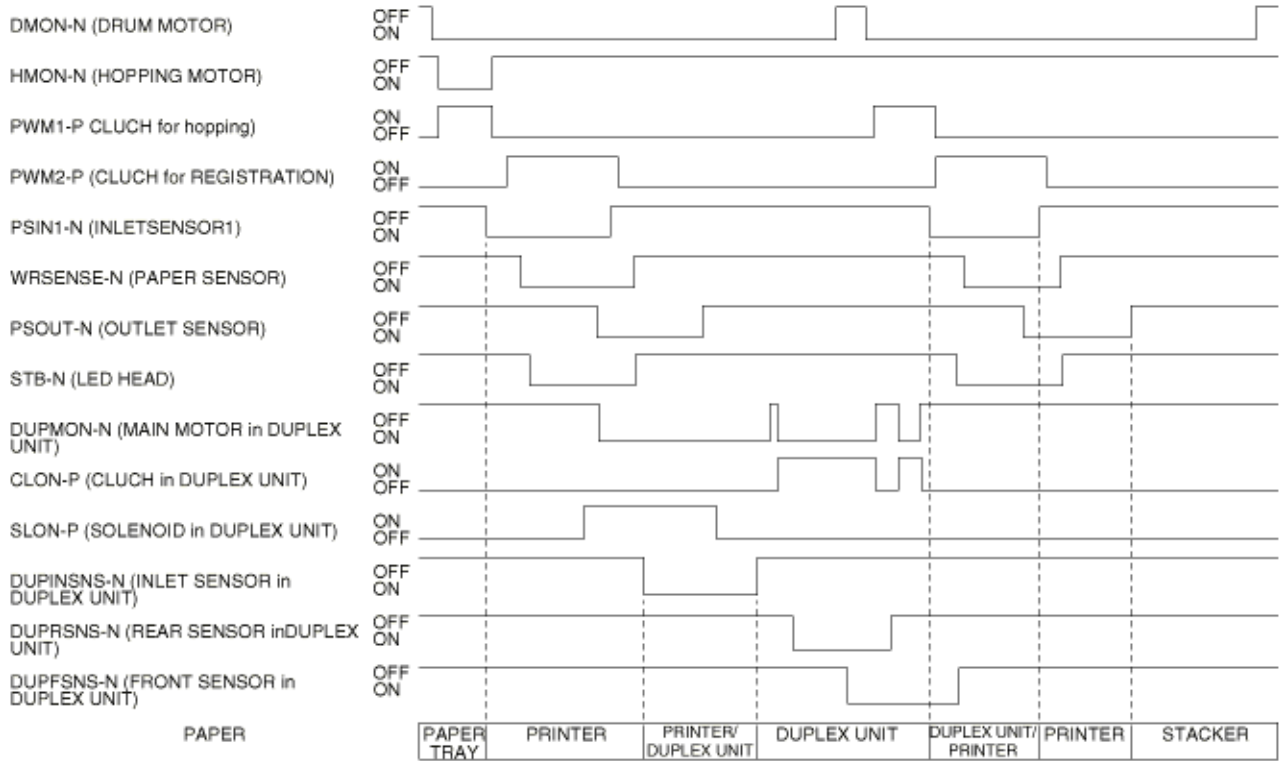

DUPLEX PRINTING TIMING CHART

2.3.3 Process operation descriptions

(1) Hopping

Hoppings from the first tray and the front feeder are effected by a single hopping motor in the mechanism shown below.

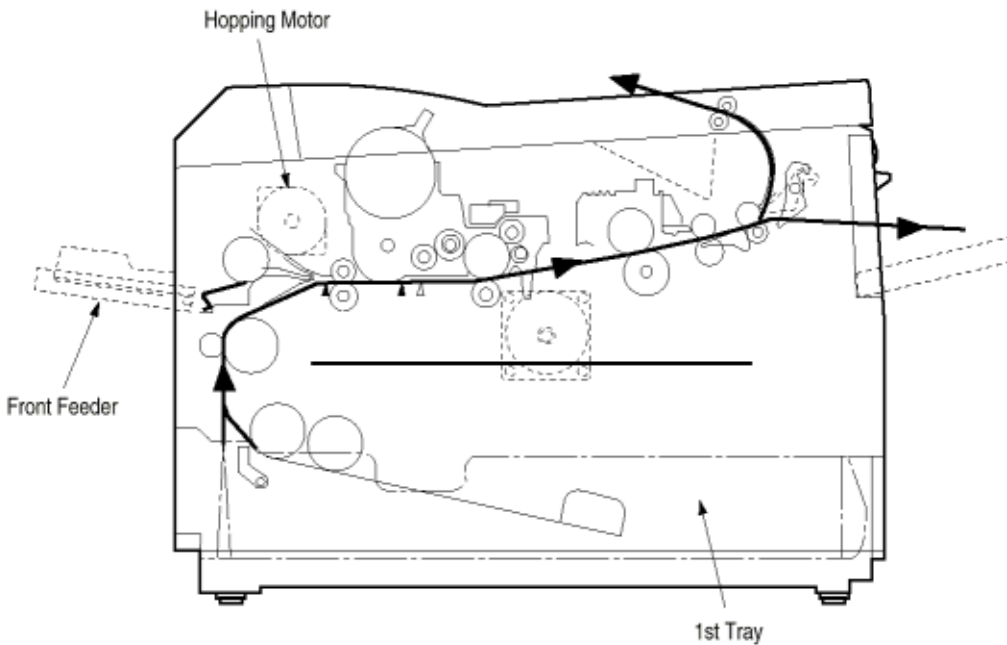

Turning the Hopping motor in direction a (CW) drives the 1st Hopping Roller. Turning the Hopping motor in direction b (CCW) drives the Front Hopping Roller. Gear C and Hopping roller built-in one way bearing, so that turning each of these gears in reverse direction will not be transmitted to the corresponding roller.

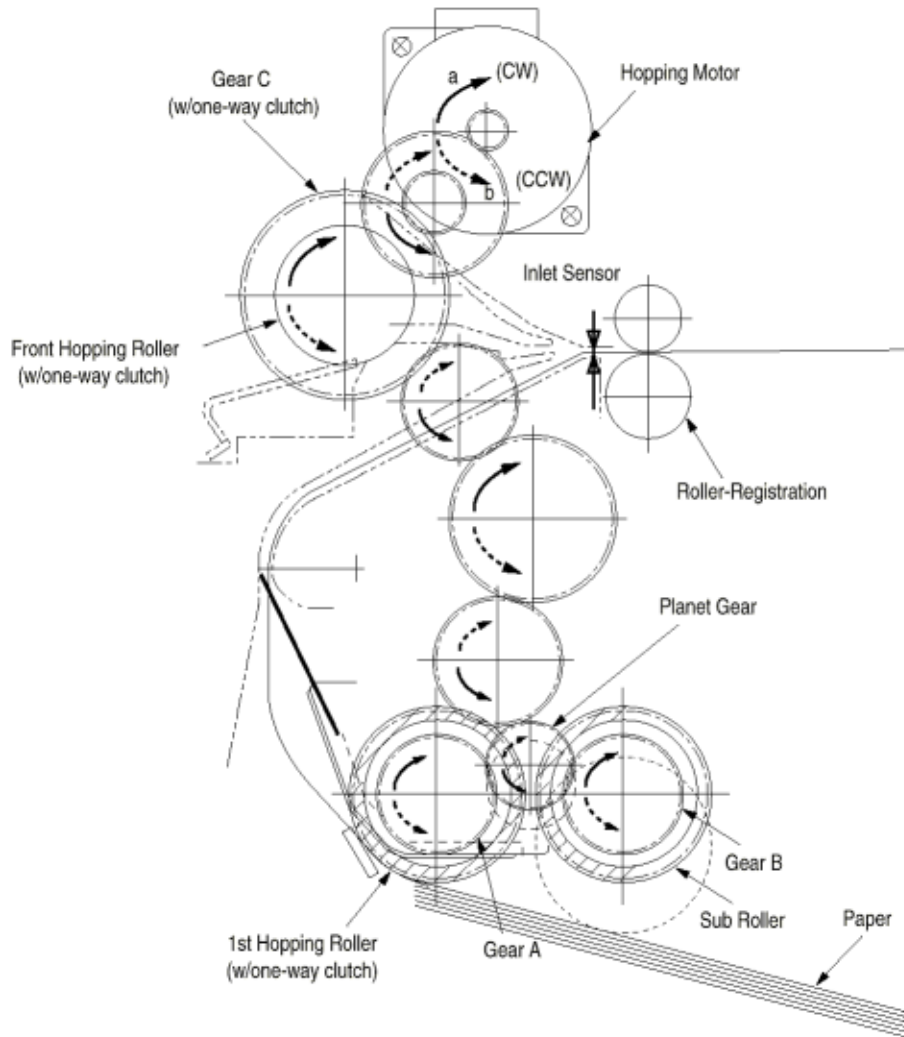

(a) Hopping from the 1st Tray

1 Hopping

Rotating the Hopping Motor in direction a (CW) drives the 1st Hopping Roller and the Sub Roller then pick up a sheet of paper in the 1st tray. The Main Motor is always driven in direction c (CCW) on printing. After the paper is fed approx. 30mm from the tray, the Clutch (Feed) drives the Align Roller to advance the paper until the Inlet Sensor turns on.

2 Aligning

After turning on the Inlet Sensor, the paper fed by a predetermined length and choked up to the wedge space formed by the Registration Roller and the Pressure Roller to align the skew of the paper.

3 During the paper fed from the 1st tray, the built-in clutch of Gear C is idled and does not drive the Front Hopping Roller.

4 Feeding

After aligning the paper, the Hopping Motor is turned off and stops hopping. Also the Clutch (Feed) is turned off and the Align Roller idles freely. Then the Clutch (Registration) is turned on and the Registration Roller starts to feed the paper. After the paper is fed, the 1st Hopping Roller idles freely by releasing built-in one way clutch, also the Sub

Roller idles freely by escaping the Planet Gear.

5 Printing starts after the paper turns off the Write Sensor.

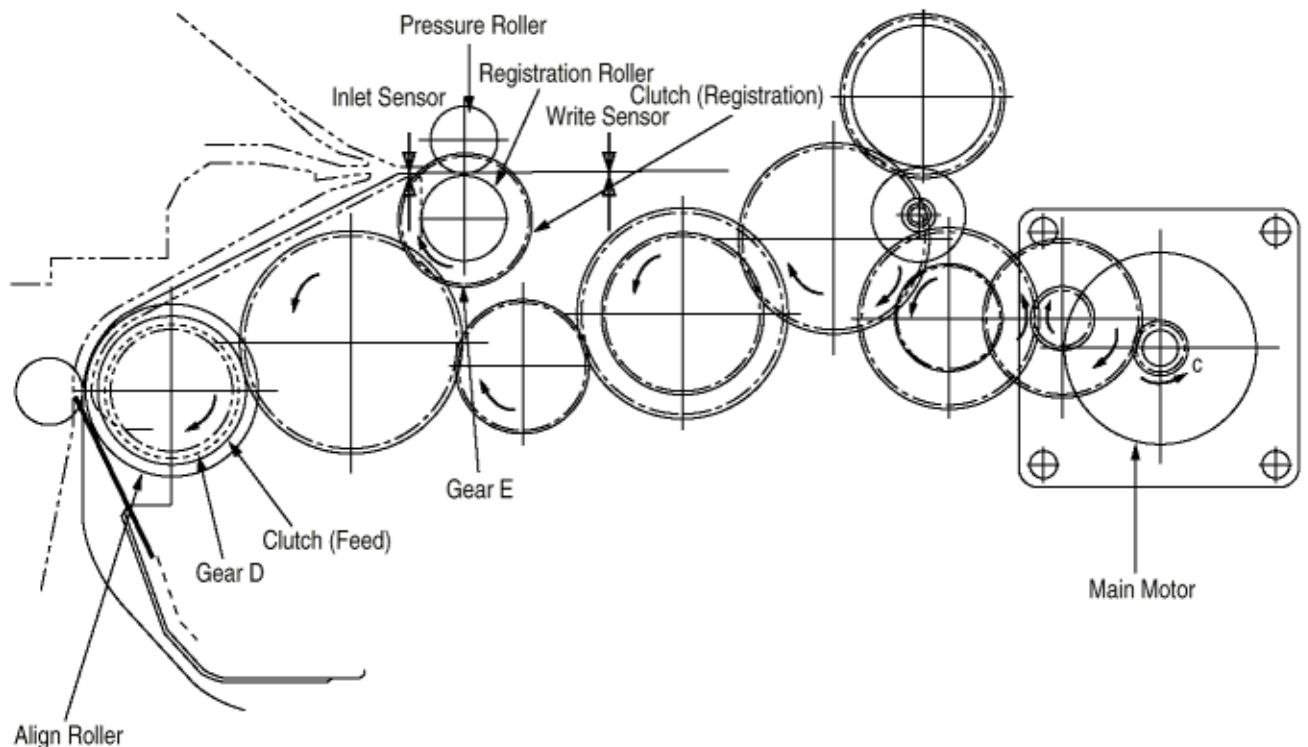

(b) Hopping from the Front Feeder

1 Hopping

The Front Feeder Plate is normally locked at the lower position by the Release Lever activating the Micro Switch. The top of the FF Cam which is attached to the end of the Front Hopping Shaft is normally located in the upper position (0 to 30 degree : home position). Rotating the Hopping Motor in direction b (CCW) drives the Front Hopping Shaft, the attached FF Cam and the Front Hopping Roller. When the FF Cam is rotated approx. 60 degrees, the Release Lever is pushed and the Front Feeder Plate lifts up allowing the Front Hopping Roller to pick up a sheet of paper. When the FF Cam is rotated approx. 180 degree, the Front Feeder Plate is pushed down and locked by the Release Lever again. When the FF Cam is rotated approx. 275 degrees the paper is fed until the Inlet Sensor turns off.

2 Aligning

After turning on the Inlet Sensor, the paper is fed a predetermined length and choked up to the wedge space formed by the Registration Roller and the Pressure Roller to align the skew of the paper.

3 While the paper is fed from the Front Feeder Plate, the one way clutch of 1st Hopping Roller is idled and does not drive the 1st Hopping Roller and the Sub Roller.

4 Feeding

After aligning the paper, the Hopping Motor is turned off and stops hopping. Then the Clutch (Registration) is turned on and the Registration Roller starts to feed the paper. After the paper is fed, the Front Hopping Roller drives the Front Hopping Shaft and the attached FF Cam with a small idle torque of the built-in one way clutch advancing to the Release Lever. The one way clutch is slipped and the FF Cam is stopped at the upper position (home position). The Front Hopping Roller idles until the paper clears the roller.

5 Printing starts after the paper turns off the Write Sensor.

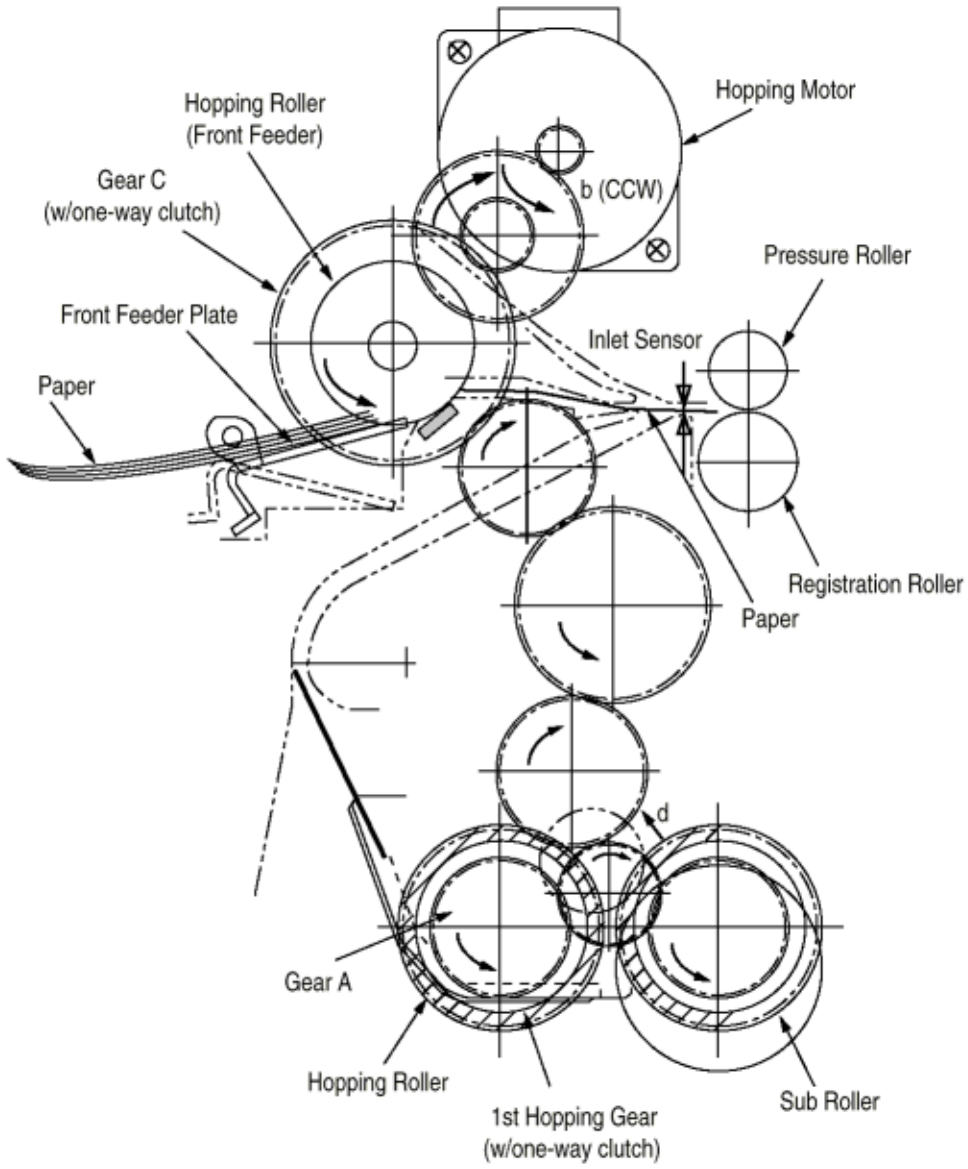

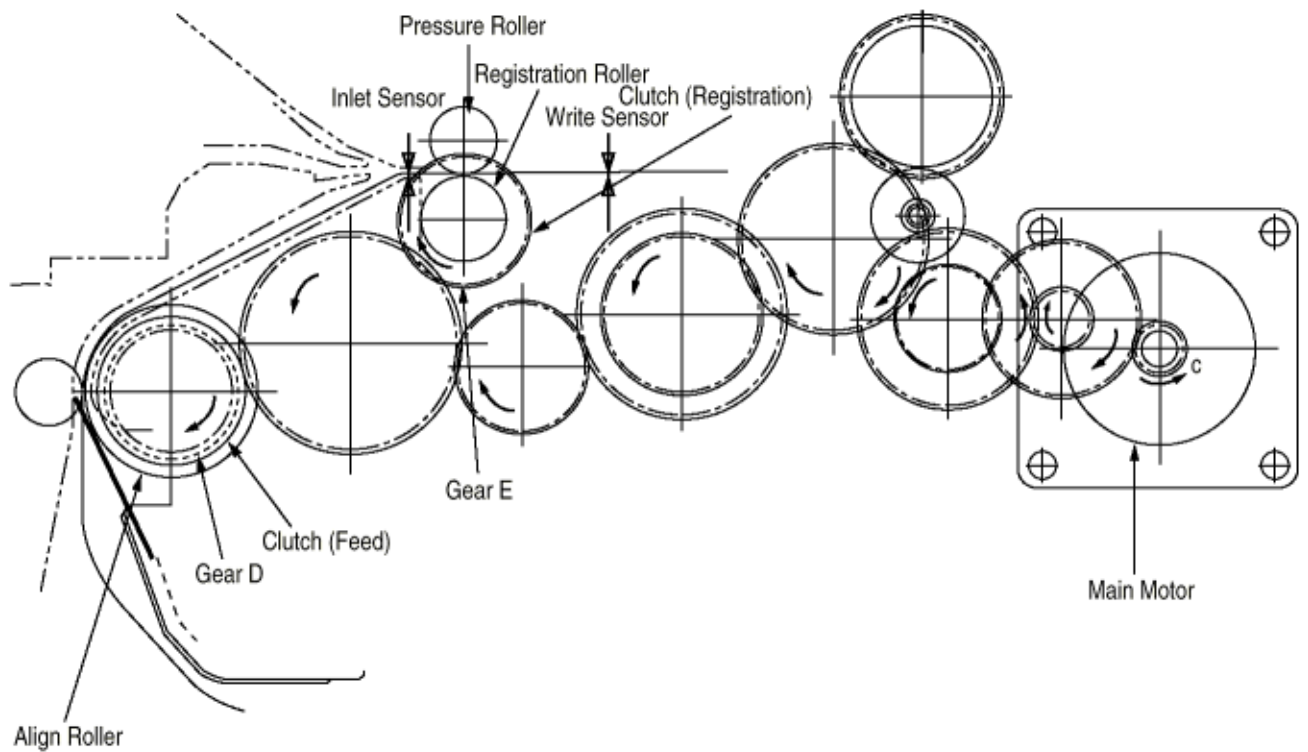
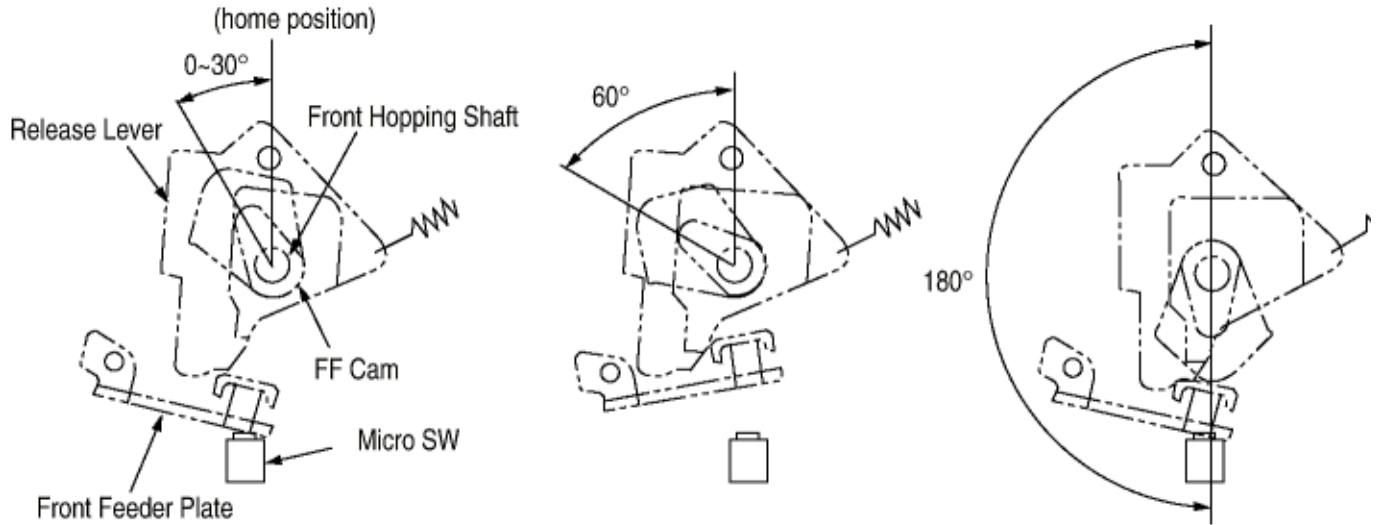

(2) Feeding

After finishing hopping, the pulse motor dedicated for driving the registration roller rotates to drive the registration roller. The registration roller advances the paper until it comes out of the registration roller.

When the leading edge of the paper causes the paper sensor to turn on, the printing is started synchronously.

Although Gear D is always rotating due to an all-time rotation of the main motor in direction c, the registration roller

would not rotate because the clutch (registration) is turned off. After completion of hopping, turn on the clutch (registration) to drive the registration roller. The registration roller will drive the paper until the paper has passed.

(3) Charging

Charging is effected by applying a DC minus voltage to the charge roller that is in contact with the image drum surface.

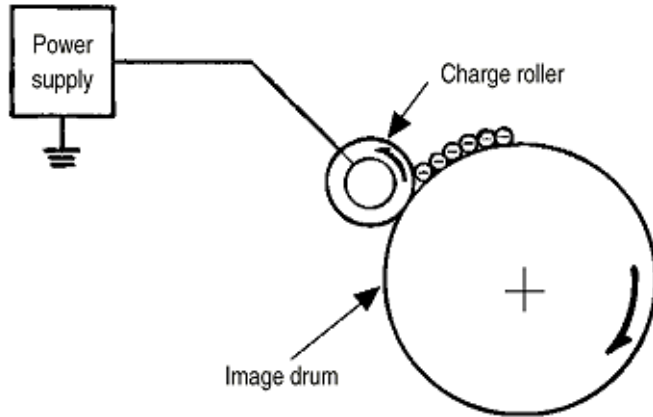

(4) Exposure

Light emitted from the LED head radiates the image drum surface with negative charges. The surface potential of the charged part of the image drum drops, thereby forming an electrostatic latent image associated with the image signal.

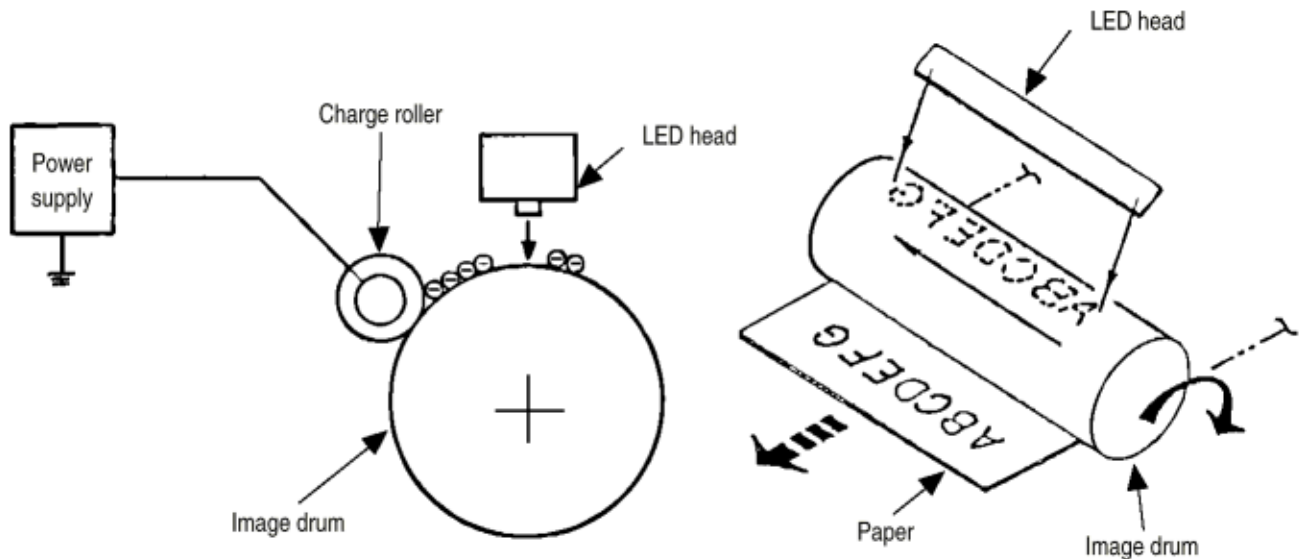

(5) Developing

Toner is attracted to the electrostatic latent image on the image drum surface to convert it into a visible toner image. Developing takes place at the contact between the image drum and the developing roller.

1 As the toner supply roller rotates while rubbing on the developing roller, a friction charge is generated between the developing roller and the toner, allowing the toner to be attracted to the developing roller. (The developing roller surface is charged positive and the toner, negative.)

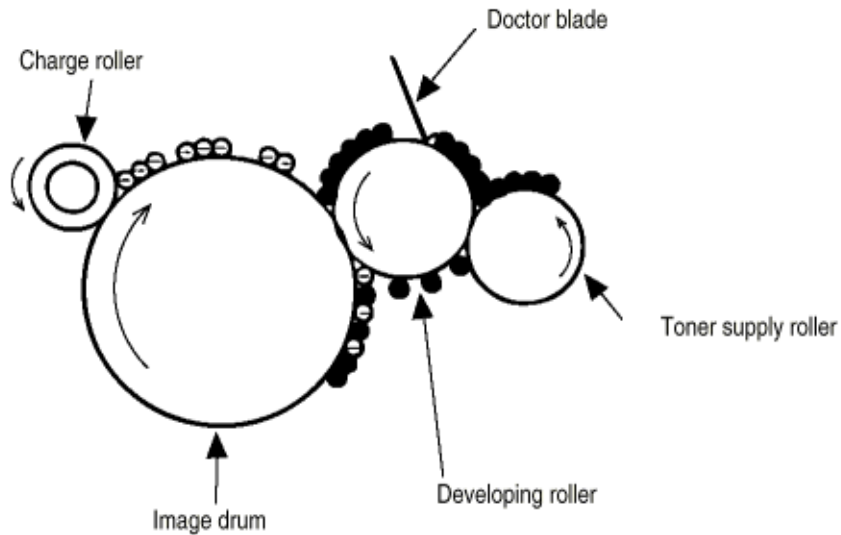

2 The toner attracted to the developing roller is scraped off by the doctor blade, forming a thin coat of toner on the developing roller surface.

3 Toner is attracted to the exposed part (low-potential part) of the image drum at the contact between the image drum and the developing roller, making the electrostatic latent image visible.

(6) Transfer

The transfer roller is composed of conductive sponge material and is designed to make the image drum surface and the paper closely into contact.

Paper is placed over the image drum surface, and a positive charge, opposite in polarity to the toner, is applied to the paper from its reverse side.

The application of a high positive voltage from the power supply to the transfer roller causes the positive charge induced to the transfer roller surface to be transferred to the paper at the contact between the transfer roller and the paper. As a result, toner charged negative that is attracted to the image drum surface is transferred to the upper side of the paper by the positive charge on the lower side of the paper.

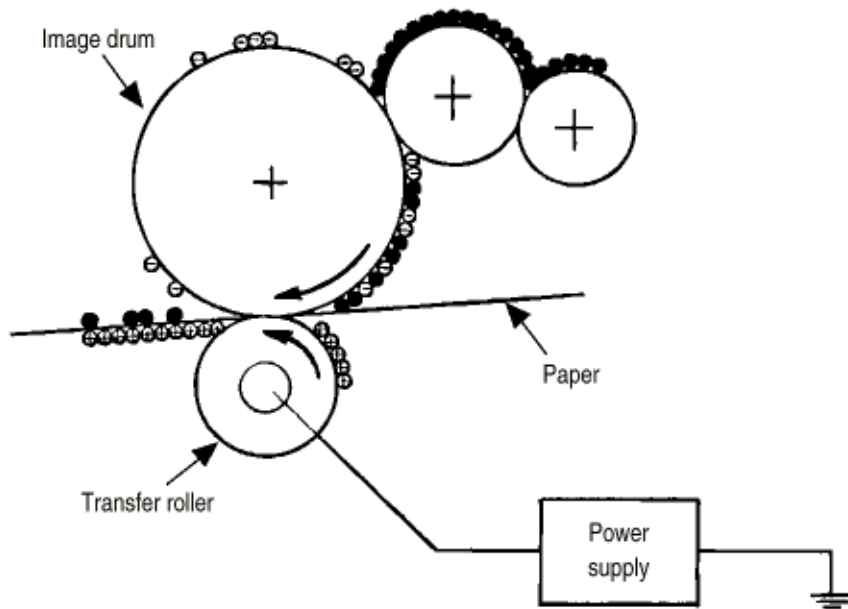

(7) Fusing

After the end of the transfer, the unfused toner image is fused on the paper under heat and pressure as it passes between the heater roller and the back-up roller. The heater roller with a Teflon coating incorporates a 750W heater (Halogen lamp), which heats the heat roller.

A thermistor which is in contact with the heater roller regulates the heater roller at a predetermined temperature (about 180 ~ 200°C). A safety thermostat cuts off voltage supply to the heater by opening the thermostat in the event of abnormal temperature rises.

The back-up roller is held under a pressure of 5 kg from the pressure spring at each side.

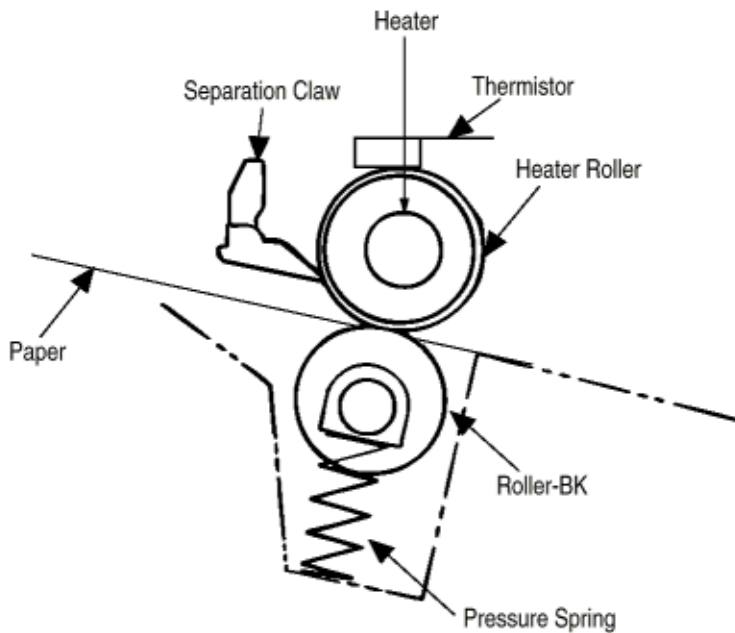

(8) Cleaning

After the end of the transfer, residual toner on the image drum is attracted to the cleaning roller temporarily by static electricity to clean the image drum surface.

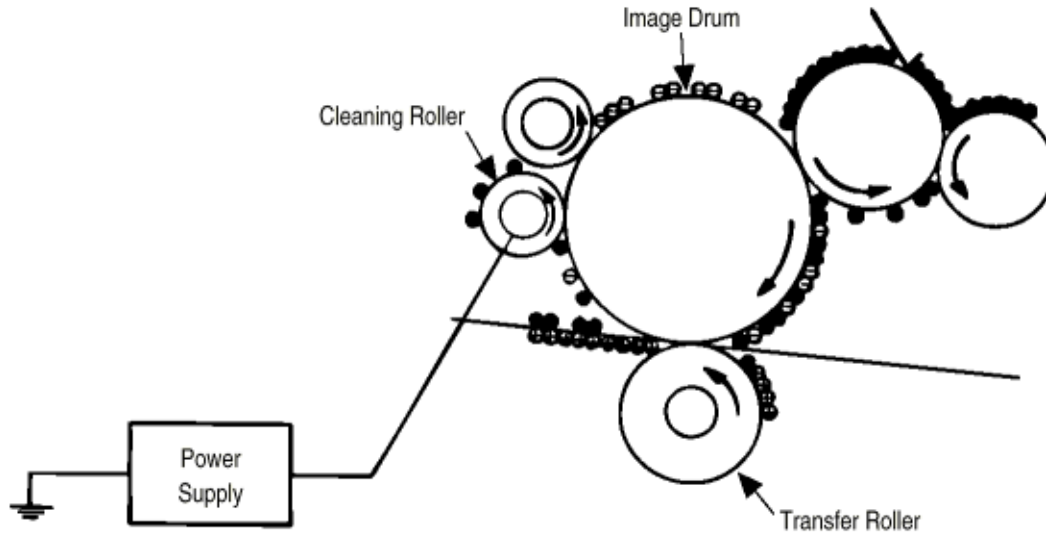

(9) Cleaning of rollers

The charge roller, transfer roller and cleaning roller are cleaned in the following cases:

- In warming up at power-on time
- In warming up after the cover is opened and closed
- When the number of accumulated sheets is 10 or more and the printout operation ends

Changes in bias voltage applied to each roller move adhesive toner from the roller to the image drum and return it to the developer.

2.3.4 Revision of LED Head Illumination

An LED correcting head, which is capable of correcting the illumination of the LED for each dot, is being used in this printer. LED illumination correction function of 16 steps is carried out by using an EEPROM which is installed in the LSI that maintains the LED illumination correction values, and an LED correction drivers together as a pair.

The LED correcting head consists of the correction control LSI , LED drivers , and an LED array.

The block diagram of the LED correcting head is shown below.

(1) Both sides wire-bonding head

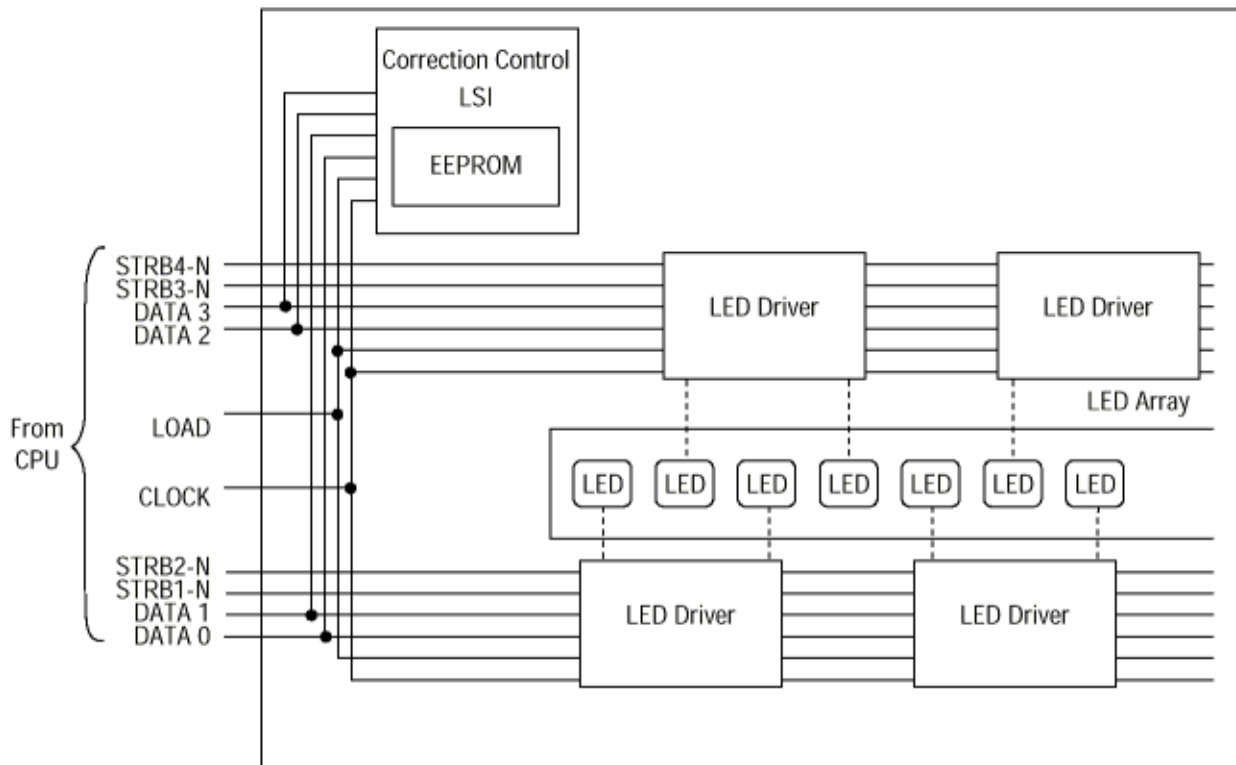

In OKIPAGE 18/18n, the correction control of LED head is executed directly by the CPU.

The procedure is as follows

- (i) LED head is set to the correction control read mode and all correction data stored in EEPROM within the correction control LSI are read by CPU, and stored temporarily in the memory.
- ii) Next LED head is set to the correction control direct mode and the correction data stored temporarily in the memory is transferred directly to the LED driver.

(i) Read of correction data

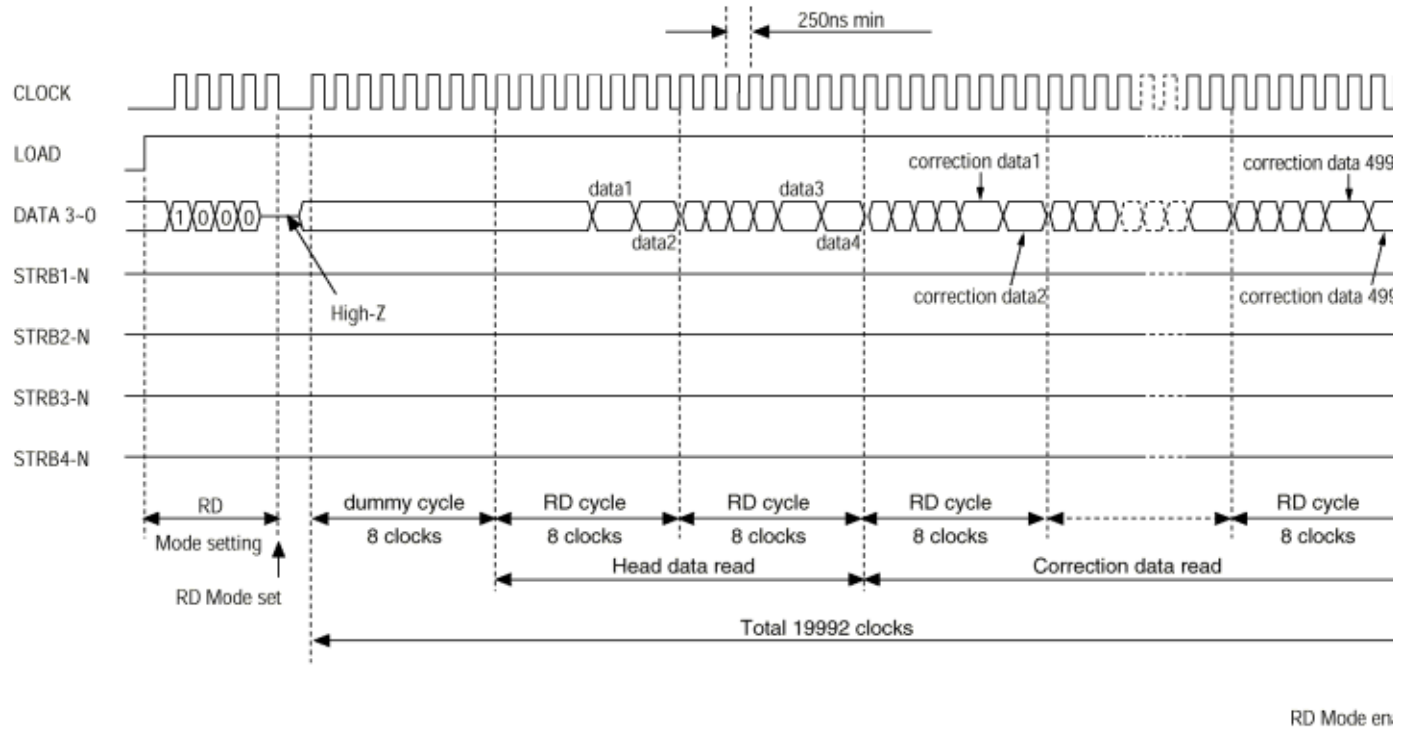

(ii) Transfer of correction data to head driver correction data

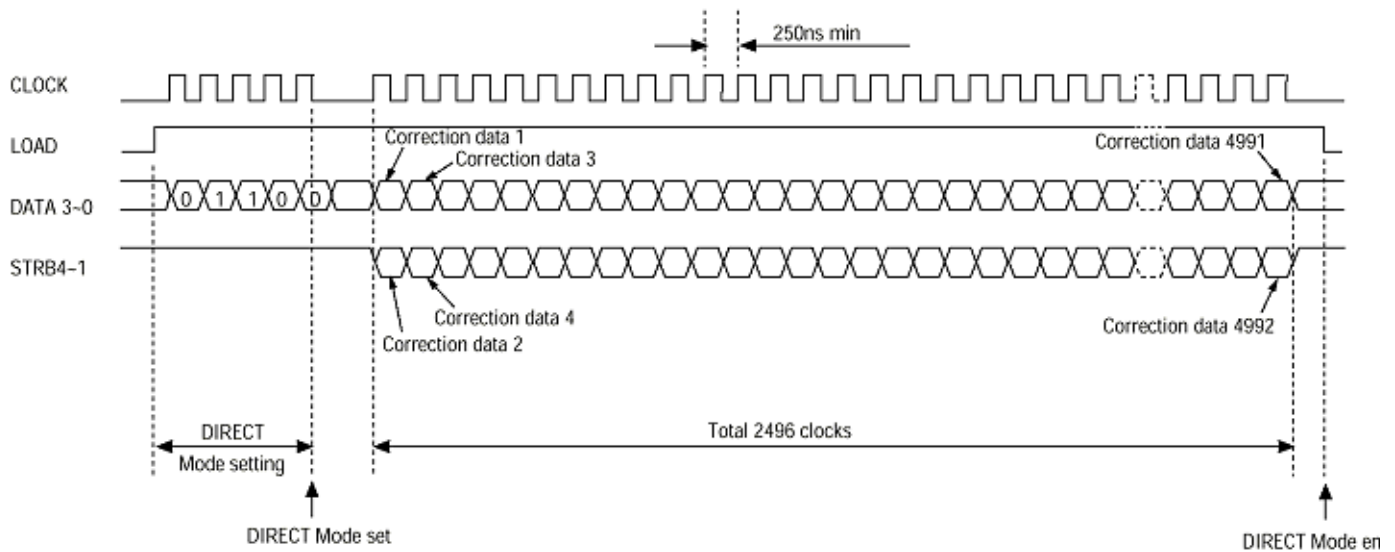

(2) One side wire-bonding head

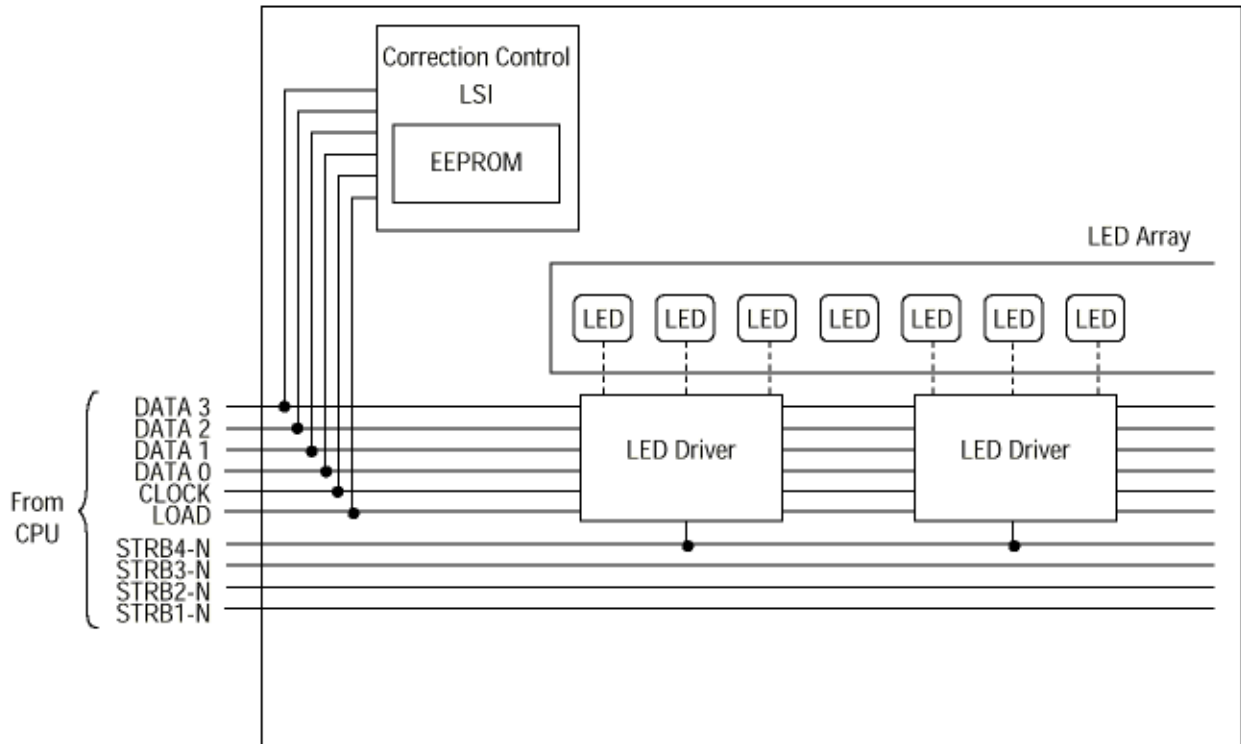

(i) LED head is set to the correction control read mode and all correction data stored in EEPROM within the correction control LSI are read by CPU, and stored temporarily in the memory.

(ii) Next, LED head is set to the correction control direct mode and the correction data stored temporarily in the memory is transferred directly to the LED driver.

(i) Read of correction data

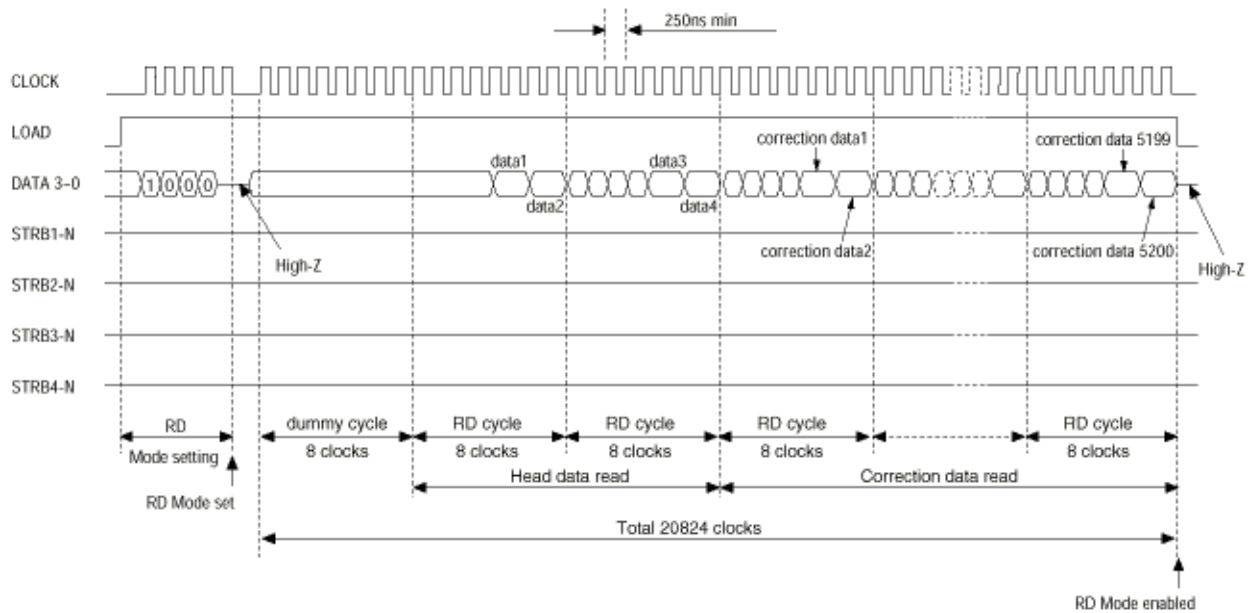

(ii) Transfer of correction data to head driver correction data

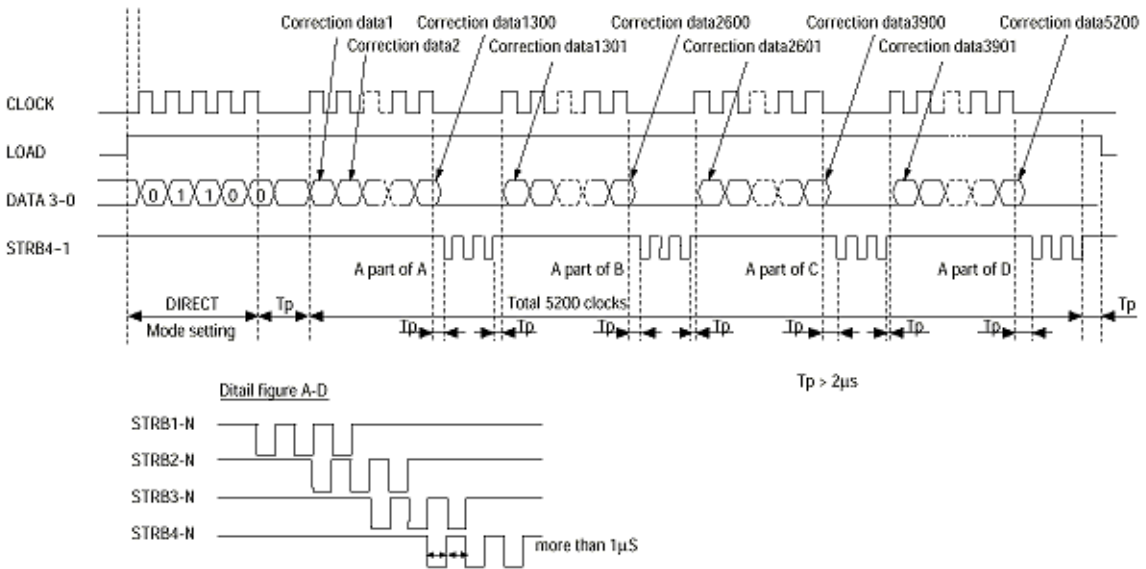

The LED driver corrects the LED illumination by controlling the LED current. The LED illumination can be set in 16 steps, with 7 steps in the direction of illumination increase in relation to the standard value, and 8 steps in the direction of decrease. For this reason, the LED correction data is a 4-bit data for each dot.

The relationship between the LED correction data and LED current correction steps with the LED driver used in an LED head is shown below.

LED Correction Data

Correction Data				Correction Step	Correction Mode
msb b3	b2	b1	lsb b0		
1	0	0	0	+16%	↑
0	1	1	1	+14%	↑
0	1	1	0	+12%	Correction by increasing illumination
0	1	0	1	+10%	
0	1	0	0	+8%	
0	0	1	1	+6%	
0	0	1	0	+4%	
0	0	0	1	+2%	
0	0	0	0	0%	
1	1	1	1	-2%	↓
1	1	1	0	-4%	↓
1	1	0	1	-6%	Correction by decreasing illumination
1	1	0	0	-8%	
1	0	1	1	-10%	
1	0	1	0	-12%	↓
1	0	0	1	-14%	↓

The printing operation timing chart is shown below.

Normal Mode Printing Timing Chart

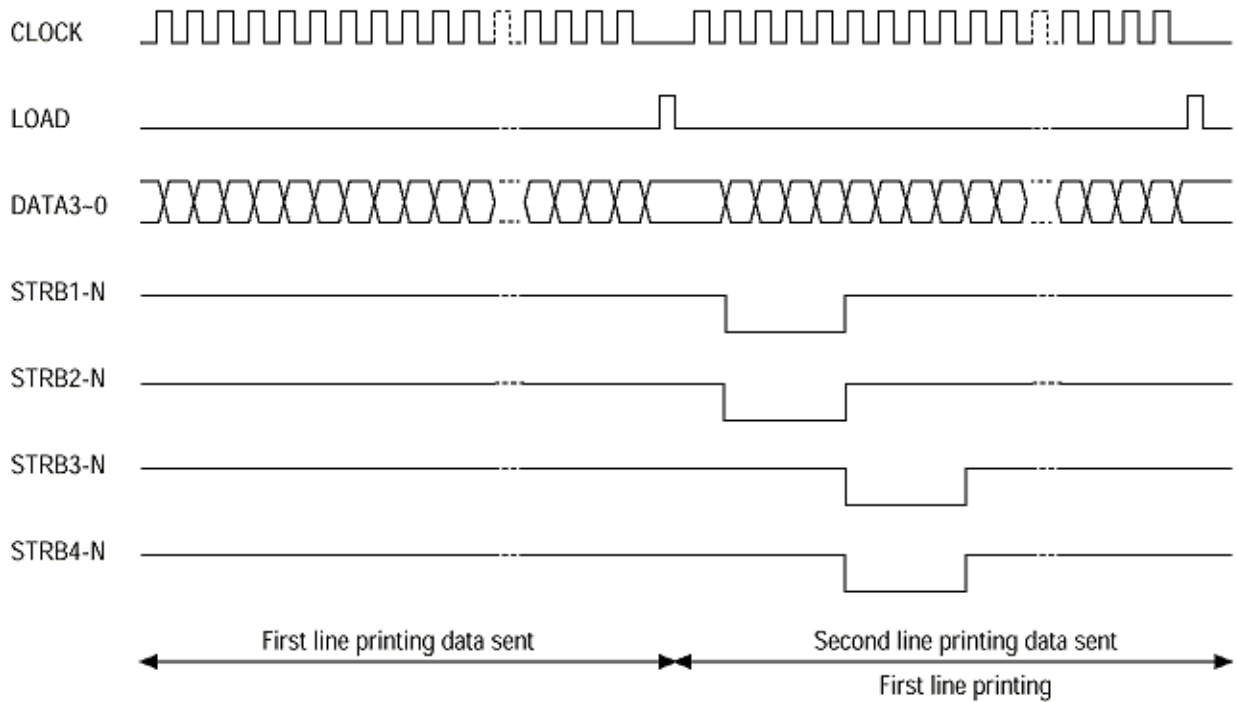

The printing operation is carried out in normal mode. Under ordinary circumstances such as when the power is turned on or when LOAD signal level is low, the normal mode is enabled. The printing operation is carried out in the following sequence. First, the printing data DATA3 through DATA0 are stored, sequentially shifted, in the shift registers of the LED drivers, by the printing data synchronous clock, CLOCK. Then the printing data stored in shift registers are latched by the high level pulse of LOAD. The latched printing data turns the LEDs on by STRB1-N through STRB4-N and actuates printing.



Service Guide OKIPAGE 18/18n

Chapter 2 Operation Description

2.4 Paper Jam Detection

The paper jam detection function supervises the paper state at power-on time and during printing. In the event that the following state occurs, this function interrupts the printing process. If any of the following errors is present, recovery printing will be performed by removing the jammed paper (namely by opening the upper cover, removing the jammed paper and closing the upper cover).

Error	Cause of Error
Paper input jam	<ul style="list-style-type: none">● At power-on time, the paper is placed at the inlet sensor.● After hopping operation is attempted three times, the leading edge of the paper does not reach the inlet sensor.
Paper feed jam	<ul style="list-style-type: none">● At power-on time, the paper is placed at the paper sensor.● The leading edge of the paper does not reach the paper sensor within a predetermined distance after the paper has reached the inlet sensor.● The trailing edge of the paper does not pass over the paper sensor within a predetermined distance after the leading edge of the paper has passed over the paper sensor.● The leading edge of paper does not reach the outlet sensor within a predetermined distance after the paper has reached the paper sensor.
Paper exit jam	<ul style="list-style-type: none">● At power-on time, the paper is placed on the outlet sensor.● The paper does not pass over the outlet sensor within a predetermined after the leading edge of the paper has reached the outlet sensor.● The paper size check with the manual feed specified considers the reference size as free size.
Paper size error	<ul style="list-style-type: none">● The size of the paper is supervised by the inlet sensors 1. It is detected that the paper does not pass over the inlet sensor 1 within predetermined range of distance.● The inlet sensor 2 detects that the size of the loaded paper is A4 or larger, or smaller than A4. The detected paper size differs from the paper size set by command or menu.● The paper size check with the manual feed specified considers the reference size as free size.



Service Guide OKIPAGE 18/18n

Chapter 2 Operation Description

2.5 Cover Open

When the stacker cover is opened, the cover open microswitch on the Power Supply Unit (High voltage) is turned off to cut the supply of +30V to the high voltage power supply circuit. As a result, all high-voltage outputs are interrupted. At the same time, the CVOPN signal is sent to the control board to notify it of the off state of the microswitch, and the Main board performs the cover open processing.

Copyright 1998, Okidata, Division of OKI America, Inc. All rights reserved. See the OKIDATA Business Partner Exchange (BPX) for any updates to this material. (<http://bpx.okidata.com>)

2.6 Toner Low Detection

- Composition

The device consists of the stirring gear which rotates at a constant rate, the stirring bar and the magnet on the stirring bar. The stirring bar rotates through the link on the protrusion in the stirring gear.

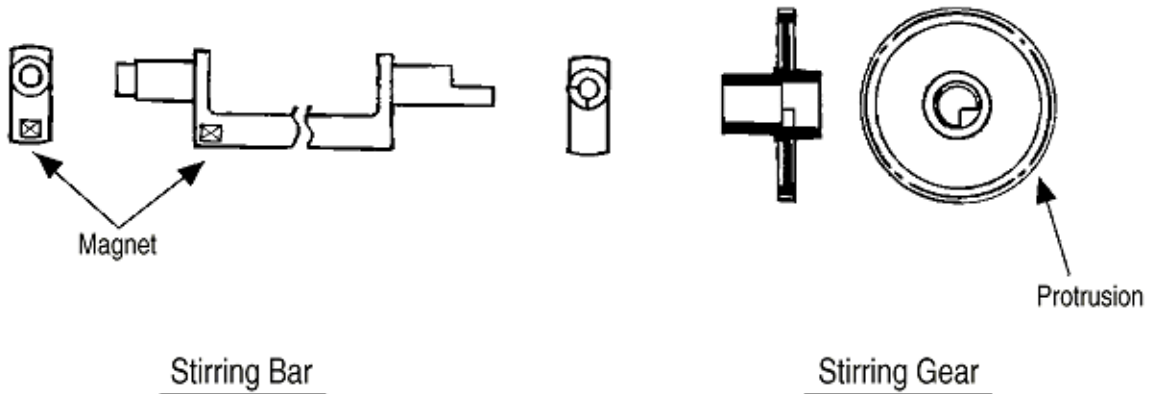

- Operation

Toner Low is detected by monitoring the time interval of the encounter of the magnet set on the sensor lever and the magnet on the stirring bar.

Operation during toner full state

- The stirring bar rotates due to the interlocking with the stirring gear.
- Even when the magnet on the stirring bar reaches the maximum height, since the other side is being dipped in the toner, the stirring bar is pushed by the stirring gear.

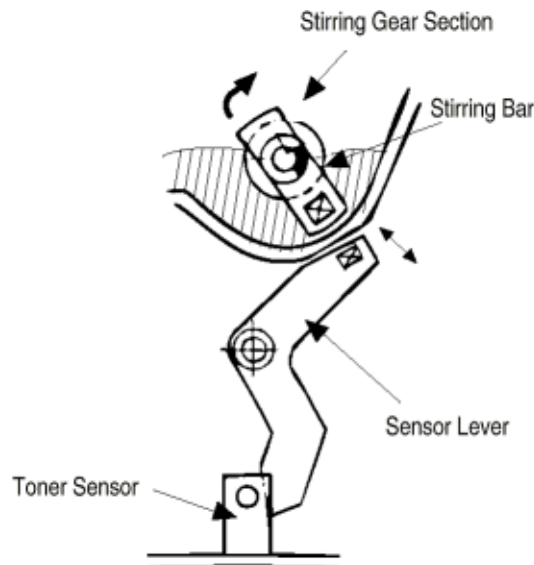

Operating during toner low state

- When the stirring bar reaches the maximum height, since there is no resistance provided by the toner on the other side, it falls to the minimum height due to its own weight. Because of this, the time interval during which it is in encounter with the magnet of the sensor lever becomes long. By monitoring this time interval, toner low can be detected.

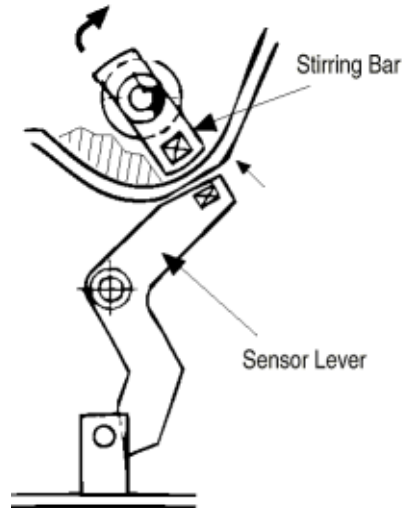

TONER FULL state

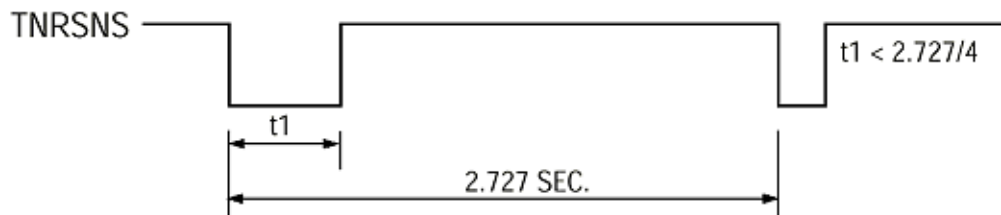

TONER LOW state

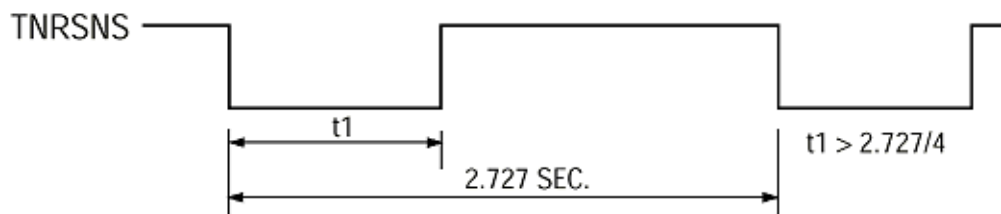

- When the toner low state is detected 2 times consecutively, Toner Low is established.
- When the toner full state is detected 2 times consecutively, Toner Low is canceled.
- When there is no change with the toner sensor for 2 cycles ($2.727 \text{ sec.} \times 2$) or more, then the Toner Sensor Alarm is activated.
- The toner sensor is not monitored while the drum motor is in halt.



Service Guide OKIPAGE 18/18n

Chapter 2 Operation Description

2.7 Stacker-full Detection

The sensor (interlocked with the lever) at the paper outlet to the stacker detects a stacker-full state (about 250 sheets) and stops printing of the ensuing pages.

Copyright 1998, Okidata, Division of OKI America, Inc. All rights reserved. See the OKIDATA Business Partner Exchange (BPX) for any updates to this material. (<http://bpx.okidata.com>)



Service Guide OKIPAGE 18/18n

Chapter 2 Operation Description

2.8 Page Size Detection

The four tab pieces are driven according to the setting position of the paper guide through the cam interlocked with the paper guide of the paper cassette.

When the paper cassette is inserted into the printer, the state of the tab pieces is detected by the microswitch to recognize the paper size.

State of Microswitches				Paper Size
SW1	SW2	SW3	SW4	
0	1	1	1	Letter
0	1	0	1	Executive
0	0	1	1	A4
1	1	1	0	Legal 14
1	0	1	1	Legal 13
1	1	0	1	B5
1	1	0	0	A5
1	0	0	1	A6 (Not available)

Copyright 1998, Okidata, Division of OKI America, Inc. All rights reserved. See the OKIDATA Business Partner Exchange (BPX) for any updates to this material. (<http://bpx.okidata.com>)



Service Guide OKIPAGE 18/18n

Chapter 3 Parts Replacement

Parts Replacements

This section explains the procedures for replacement of parts, assemblies, and units in the field. Only the removal procedures are explained here. Reverse the procedure for the installation.

3.1 Precautions for Parts Replacement

3.2 Parts Layout

3.3. Replacing Parts

Copyright 1998, Okidata, Division of OKI America, Inc. All rights reserved. See the OKIDATA Business Partner Exchange (BPX) for any updates to this material. (<http://bpx.okidata.com>)

3.1 Precautions for Parts Replacement

(1) Be starting parts replacement, remove the AC cable and interface cable.

(a) Remove the Ac cable in the following procedure:

- i) Turn off ("o") the power switch of the printer.
- ii) Disconnect the AC inlet plug of the AC cable from the AC receptacle.
- iii) Disconnect the AC cable and interface cable from the printer.

(b) Reconnect the printer in the following procedures:

- i) Connect the AC cable and interface cable to the printer.
- ii) Connect the AC inlet plug to the AC receptacle.
- iii) Turn on ("I") the power switch of the printer.

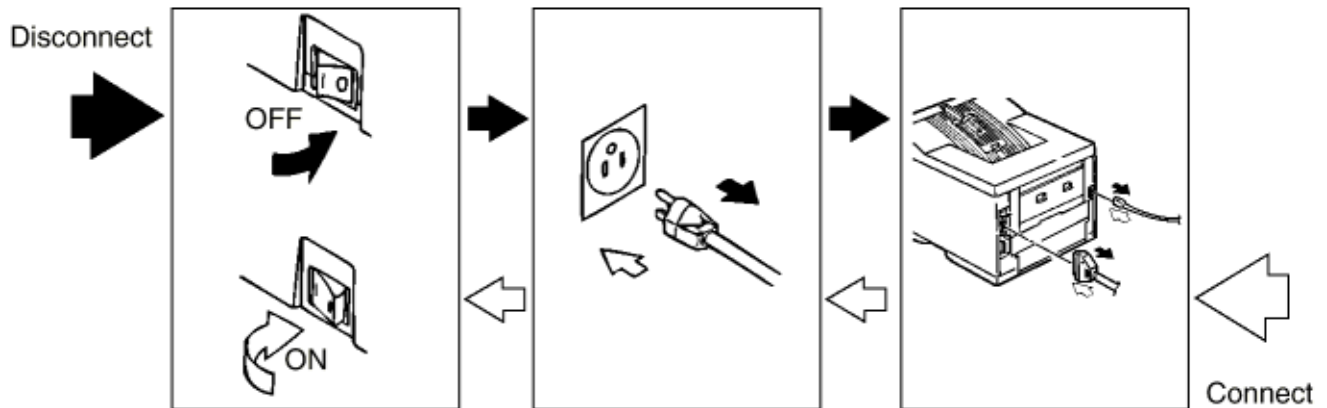

(2) Do not try disassembly as long as the printer is operating normally.

(3) Do not remove unnecessary parts: try to keep disassembly to a minimum.

(4) Use specified service tools.

(5) When disassembling, follow the determined sequence. Otherwise, parts may be damaged.









(6) Since screws, collars and other small parts are likely to be lost, they should temporarily be attached to the original positions.

(7) When handling ICs such as microprocessors, ROM and RAM, and circuit boards, do not wear gloves that are likely to generate static electricity.

(8) Do not place printed circuit boards directly on the equipment or floor.

[Maintenance Tools]

Table 3-1 lists the maintenance tools necessary for parts replacement.

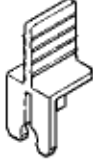
No.	Service Tools	Q' ty	Place of use	Remarks
1	 No. 1-100 Philips screwdriver	1	2-2.5 mm screws	
2	 No. 2-200 Philips screwdriver, Magnetized	1	3-5 mm screws	
3	 No. 3-100 screwdriver	1		
4	 No. 5-200 screwdriver	1		
5	 Digital multimeter	1		
6	 Pliers	1		
7	 Handy cleaner	1		
8	 LED Head cleaner P/N 4PB4083-2248P1	1	Cleans LED head	
9	 Connector remover P/N 4PP4076-5395P1	1	Disconnect connector	
10	 Holder-TR Eject P/N 40596701	1	For removing ROLLER-Transfer	



3.2 Parts Layout

This section explains the layout of main parts.

Figure 3-1

Figure 3-2

Figure 3-3

Copyright 1998, Okidata, Division of OKI America, Inc. All rights reserved. See the OKIDATA Business Partner Exchange (BPX) for any updates to this material. (<http://bpx.okidata.com>)

Service Guide OKIPAGE 18/18n Chapter 3 Parts Replacement

Figure 3-1

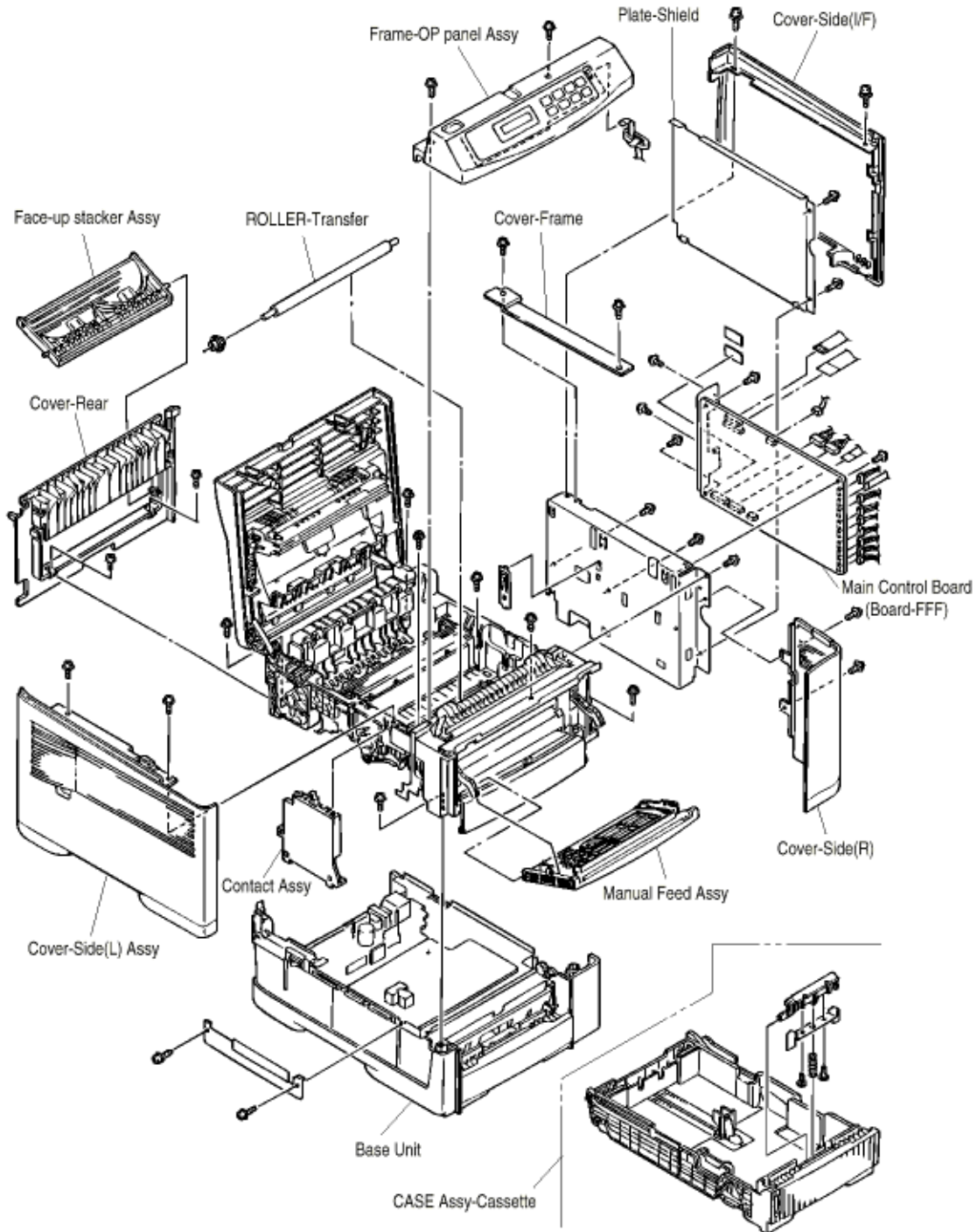

Copyright 1998, Okidata, Division of OKI America, Inc. All rights reserved. See the OKIDATA Business Partner Exchange (BPX) for any updates to this material. (<http://bpx.okidata.com>)



Figure 3-2

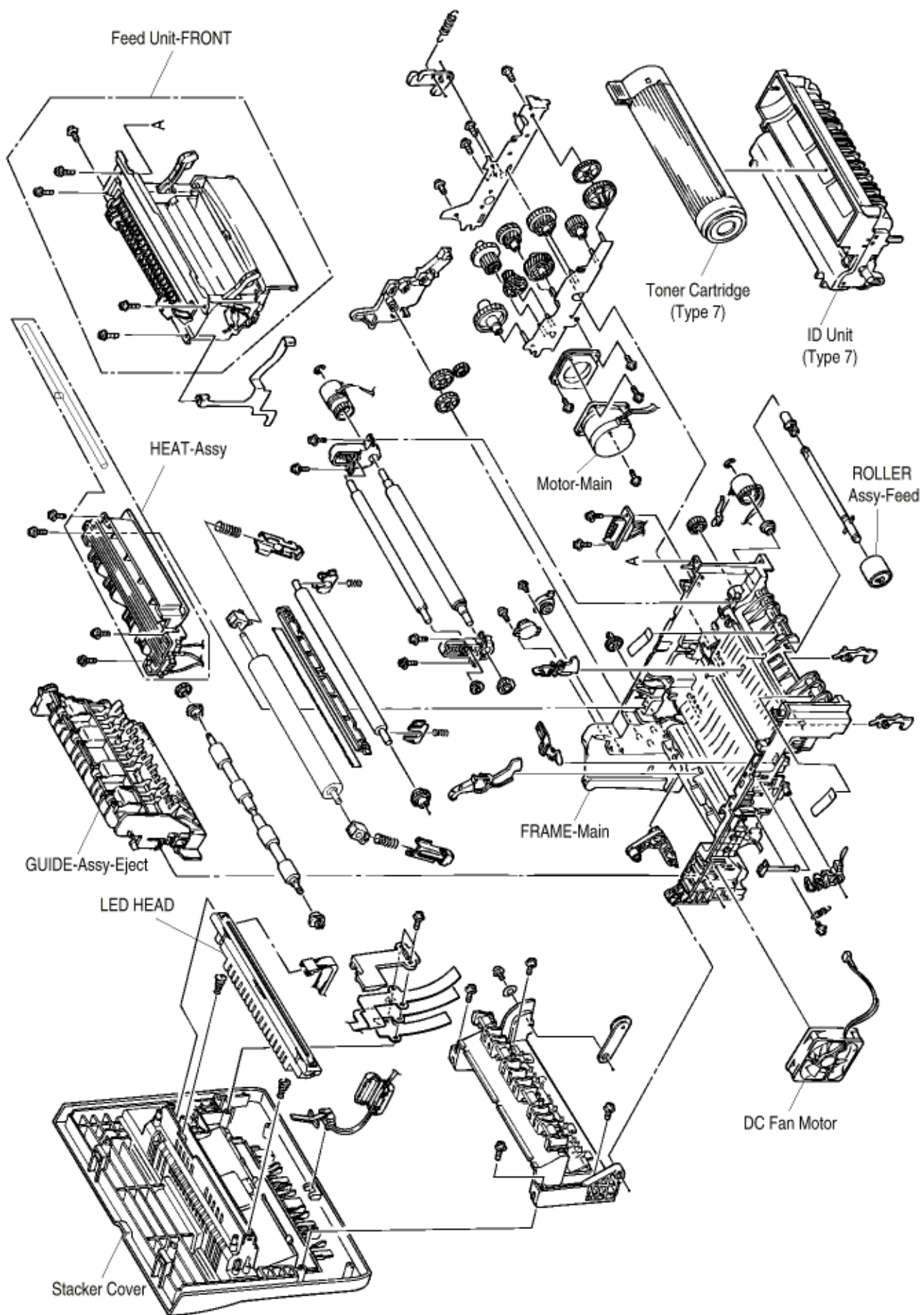

Copyright 1998, Okidata, Division of OKI America, Inc. All rights reserved. See the OKIDATA Business Partner Exchange (BPX) for any updates to this material. (<http://bpx.okidata.com>)



Service Guide OKIPAGE 18/18n
Chapter 3 Parts Replacement

Figure 3-3

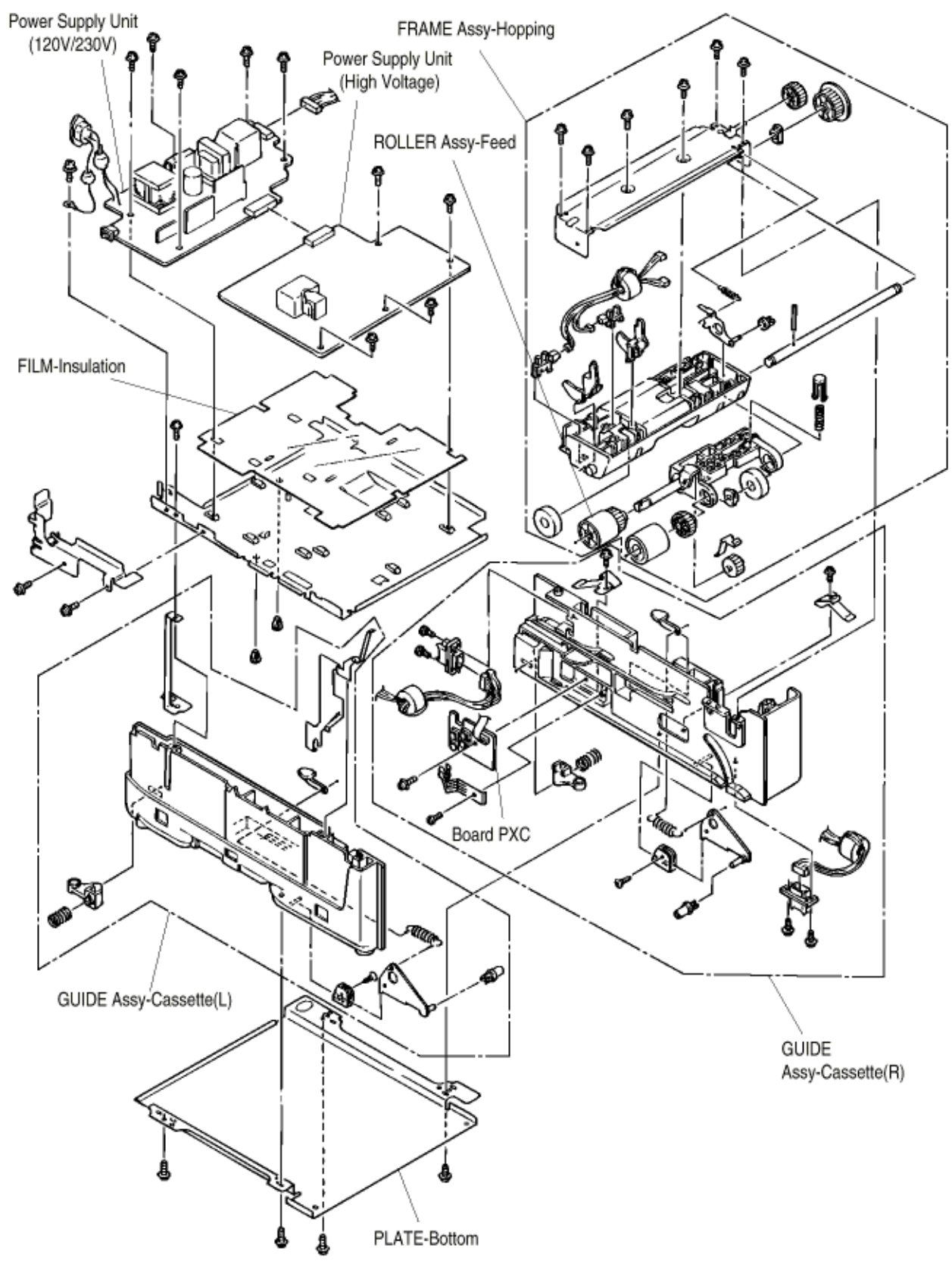

Copyright 1998, Okidata, Division of OKI America, Inc. All rights reserved. See the OKIDATA Business Partner Exchange (BPX) for any updates to this material. (<http://bpx.okidata.com>)



3.3 How to Change Parts

This section explains how to change parts and assemblies appearing in the disassembly diagram below.

3.3.1 Faceup Stacker Assy

3.3.2 Contact Assy

3.3.3 DC Fan Motor

3.3.4 OP Panel Assy

3.3.5 Board-FFF

3.3.6 Stacker Assy, Damper Arm, Cover Rear

3.3.7 Sensor Stacker Full

3.3.8 Cable cover (guide film)

3.3.9 Damper

3.3.10 Feeder Unit - Front

3.3.11 Roller Assy - Regist

3.3.12 Motor - Main

3.3.13 Guide Assy - Eject

3.3.14 Heat Assy

3.3.15 Roller feed (C)

3.3.16 Roller Assy - BK

3.3.17 Roller Assy - Feed

3.3.18 LED Head

3.3.19 Paper cassette, ROLLER Assy - Feed, ROLLER - Assy, Hopping

3.3.20 Frame Assy - Separation

3.3.21 Transfer Roller / TR Gear / TR Bearing

3.3.22 EP lock shaft

3.3.23 LEVER Assy - Out Sensor

3.3.24 Toner sensor lever

3.3.25 Paper sensor lever

3.3.26 Inlet sensor lever

3.3.27 Power supply unit

3.3.28 Lever - Paper end & Lever - Paper near end

3.3.29 Guide Assy - Cassette (L)

3.3.30 Guide Assy - Cassette (R)

Copyright 1998, Okidata, Division of OKI America, Inc. All rights reserved. See the OKIDATA Business Partner Exchange (BPX) for any updates to this material. (<http://bpx.okidata.com>)



3.3.1 Face-up Stacker Assy

- (1) Turn off the AC Power Switch and unplug the AC Power Cord from the outlet.
- (2) Disconnect the Interface Cable (1).
- (3) Open the face-up stacker assy **(2)**, unhook the right and left projections, and then remove the face-up stacker assy **(2)**.

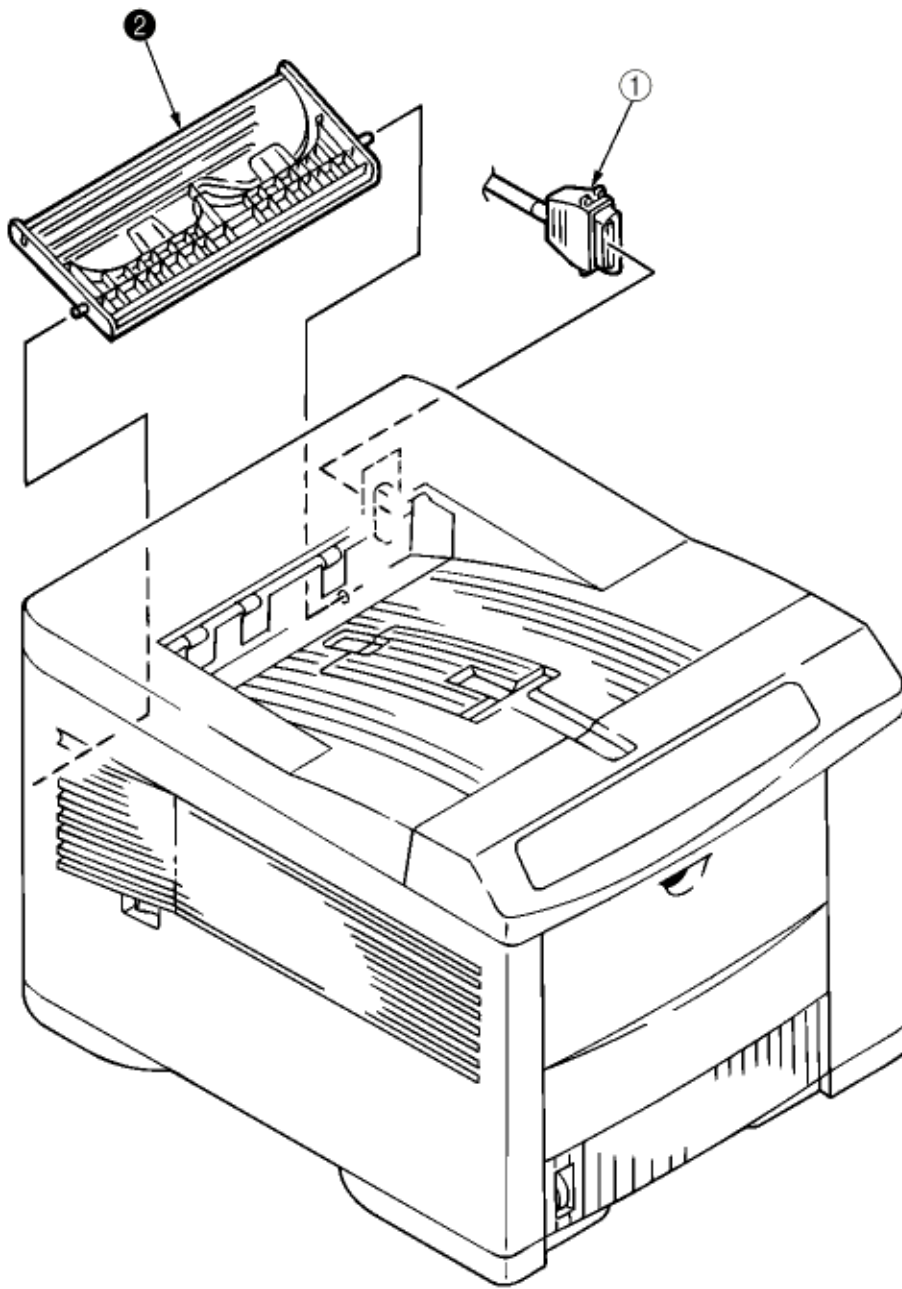

Copyright 1998, Okidata, Division of OKI America, Inc. All rights reserved. See the OKIDATA Business Partner Exchange (BPX) for any updates to this material. (<http://bpx.okidata.com>)



3.3.2 Contact Assy

- (1) Open the stacker assy (1) and unscrew 2 screws (2) to remove the cover assy-side (L)(3).
- (2) Unscrew 2 screws (4) and remove the plate (contact) (5) and contact Assy (6).

Note! Don't deform the electrode plates of the contact assy (6).

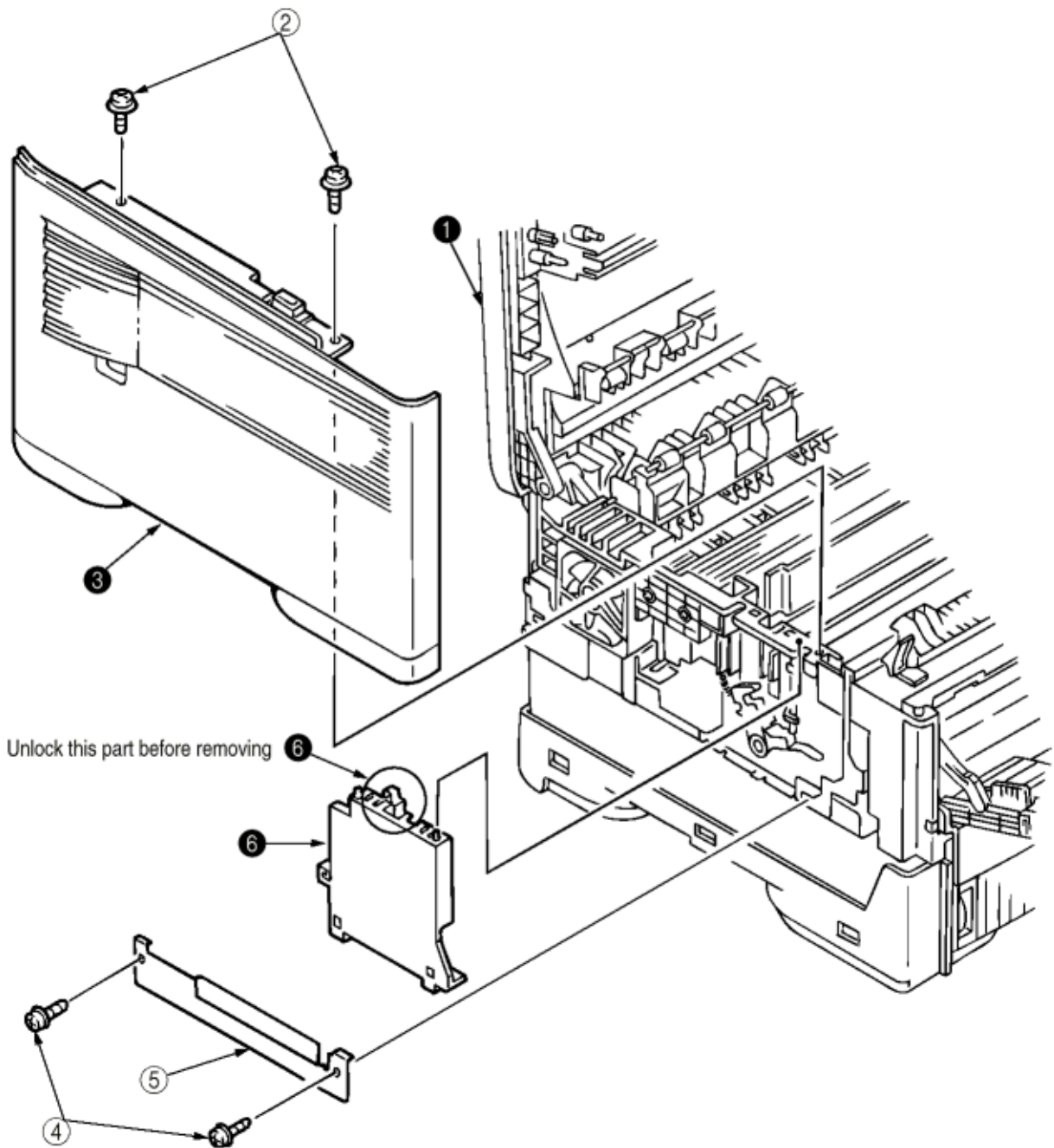

3.3.3 DC Fan Motor

- (1) Remove the cover assy-side (L). [See 3.3.2 (1)]
- (2) Remove the DC fan motor (1) by pulling out the connector of DC fan motor (1).

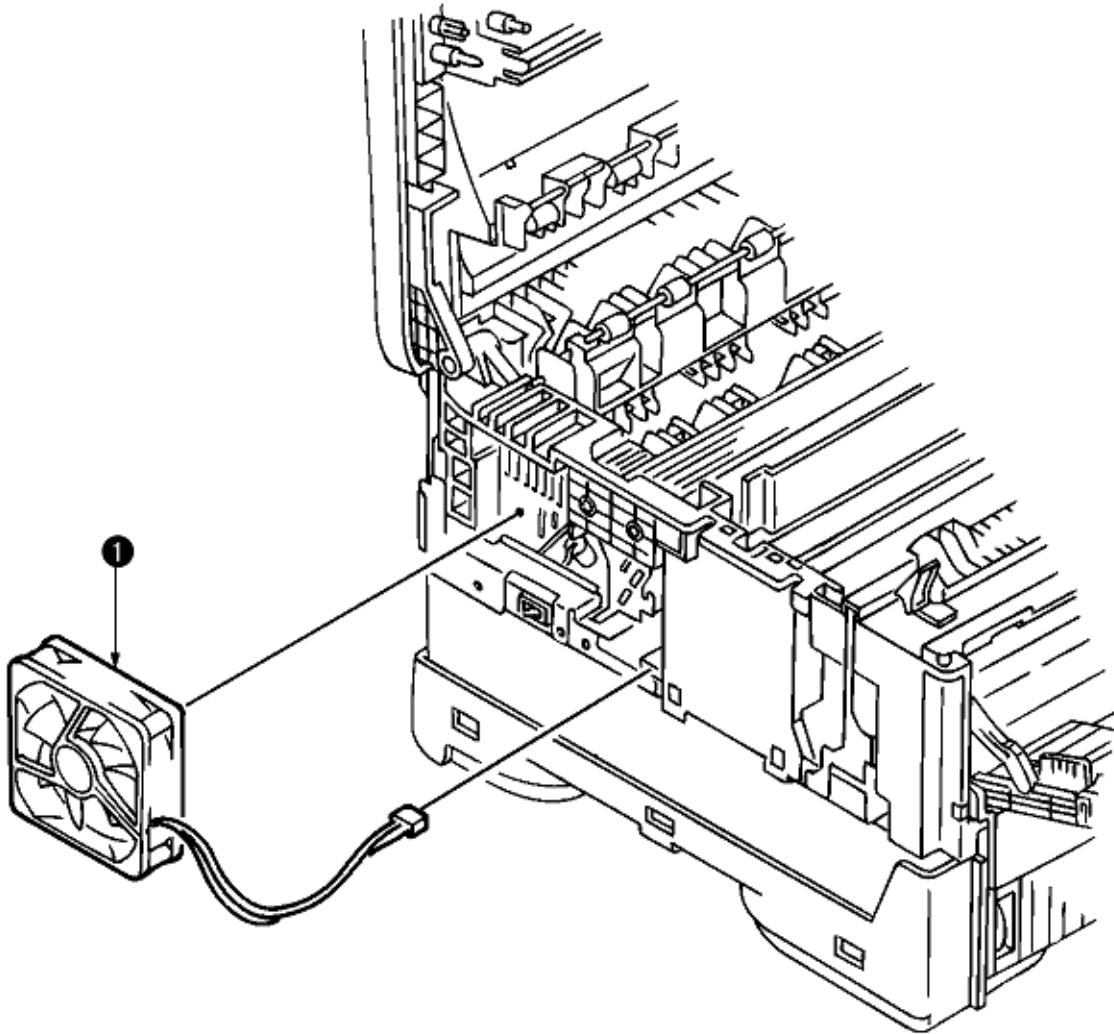



3.3.4 OP Panel Assy

- (1) Disconnect the Interface cable (1).
- (2) Open the stacker assy (2), unscrew 2 screws (3) and remove the cover assy-side (R) (4).
- (3) Remove 2 screws (5) and flexible cable (6) to remove the operator panel assy (7).

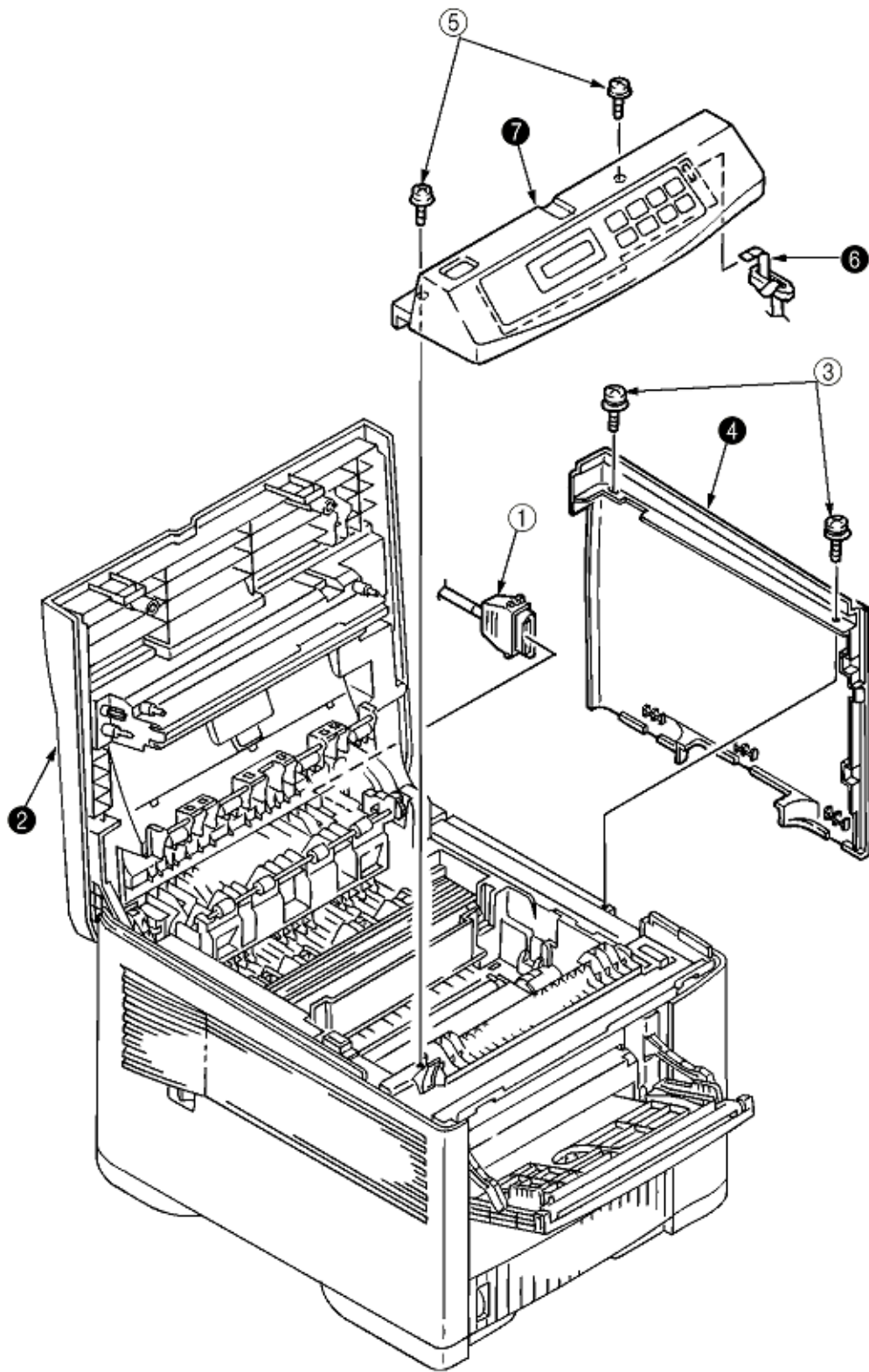

Copyright 1998, Okidata, Division of OKI America, Inc. All rights reserved. See the OKIDATA Business Partner Exchange (BPX) for any updates to this material. (<http://bpx.okidata.com>)



3.3.5 Board - FFF

- (1) Remove the operator panel assy and cover assy-side (R). [See 3.3.4]
- (2) Unscrew 2 screws (1) and remove the cover assy-corner (R) (2).
- (3) Unscrew 16 screws (3) and remove plate-shield (4).
- (4) Unscrew 3 screws (5) and 2 screws (6), unplug all the connectors (7) , and remove Board-FFF (8).

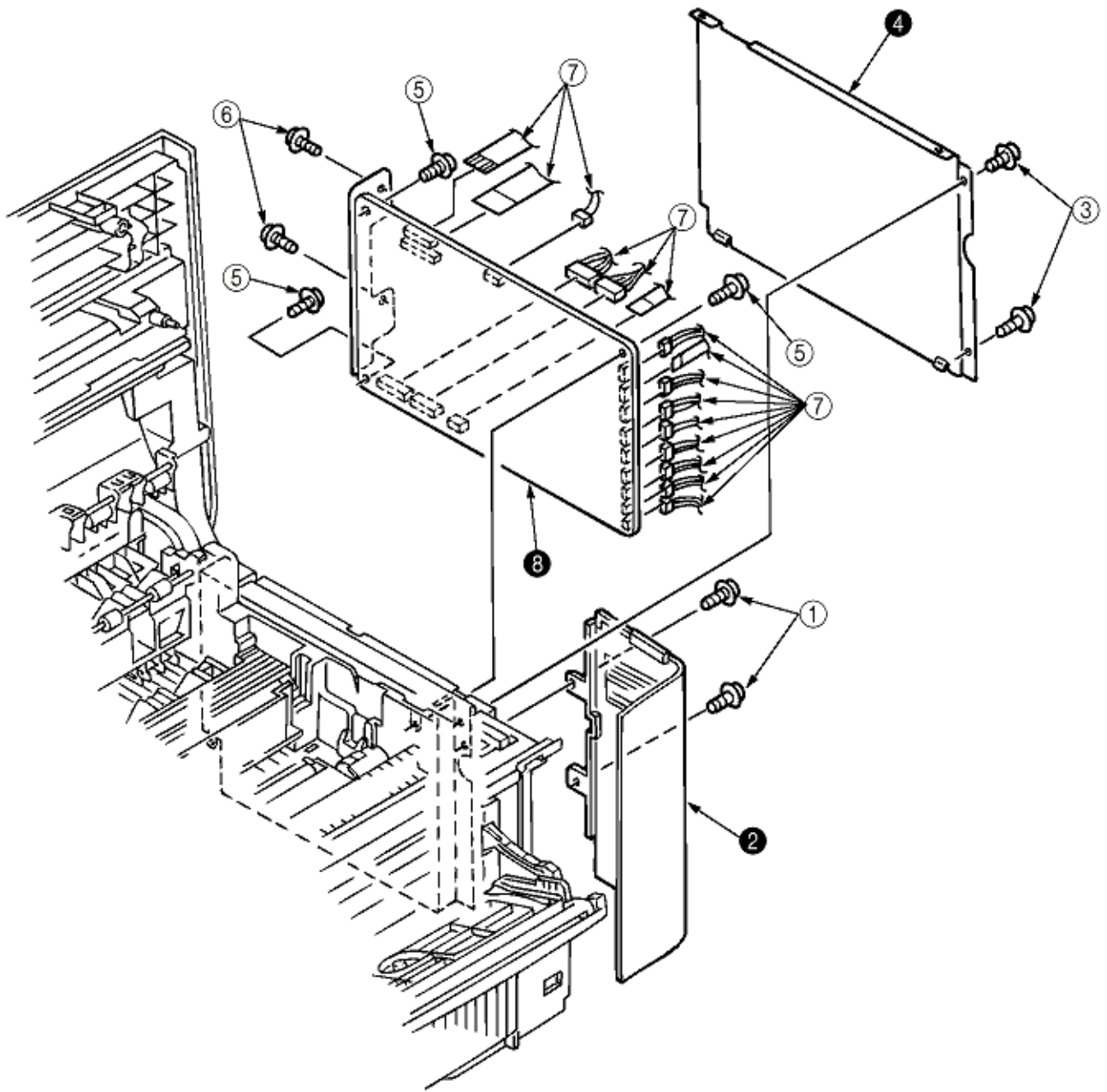

Copyright 1998, Okidata, Division of OKI America, Inc. All rights reserved. See the OKIDATA Business Partner Exchange (BPX) for any updates to this material. (<http://bpx.okidata.com>)



Service Guide OKIPAGE 18/18n

Chapter 3 Parts Replacement

3.3.6 Stacker Assy, Damper Arm, Cover Rear

- (1) Remove the face-up stacker assy. [See 3.3.1]
- (2) Remove the cover assy-side (L). [See 3.3.2 (1)]
- (3) Remove the OP panel assy. [See 3.3.4]
- (4) Remove the Board-FFF. [See 3.3.5]
- (5) Loosen 2 screws, unlock the latches from both sides and remove the rear cover **(11)**.
- (6) Unscrew 2 screws (1) and remove frame cover **(2)**.
- (7) Unscrew 3 screws (3) and remove the plate assy-side (R) (4).
- (8) Remove the lever back up release **(5)** and unlock the engagement of the projection on the right side of gear at the right side of the stacker cover.
- (9) Remove a screw 6 and washer **(7)**, and then remove the stacker assy **(8)**. (At this time, the damper arm **(9)** can also be detached simultaneously.)

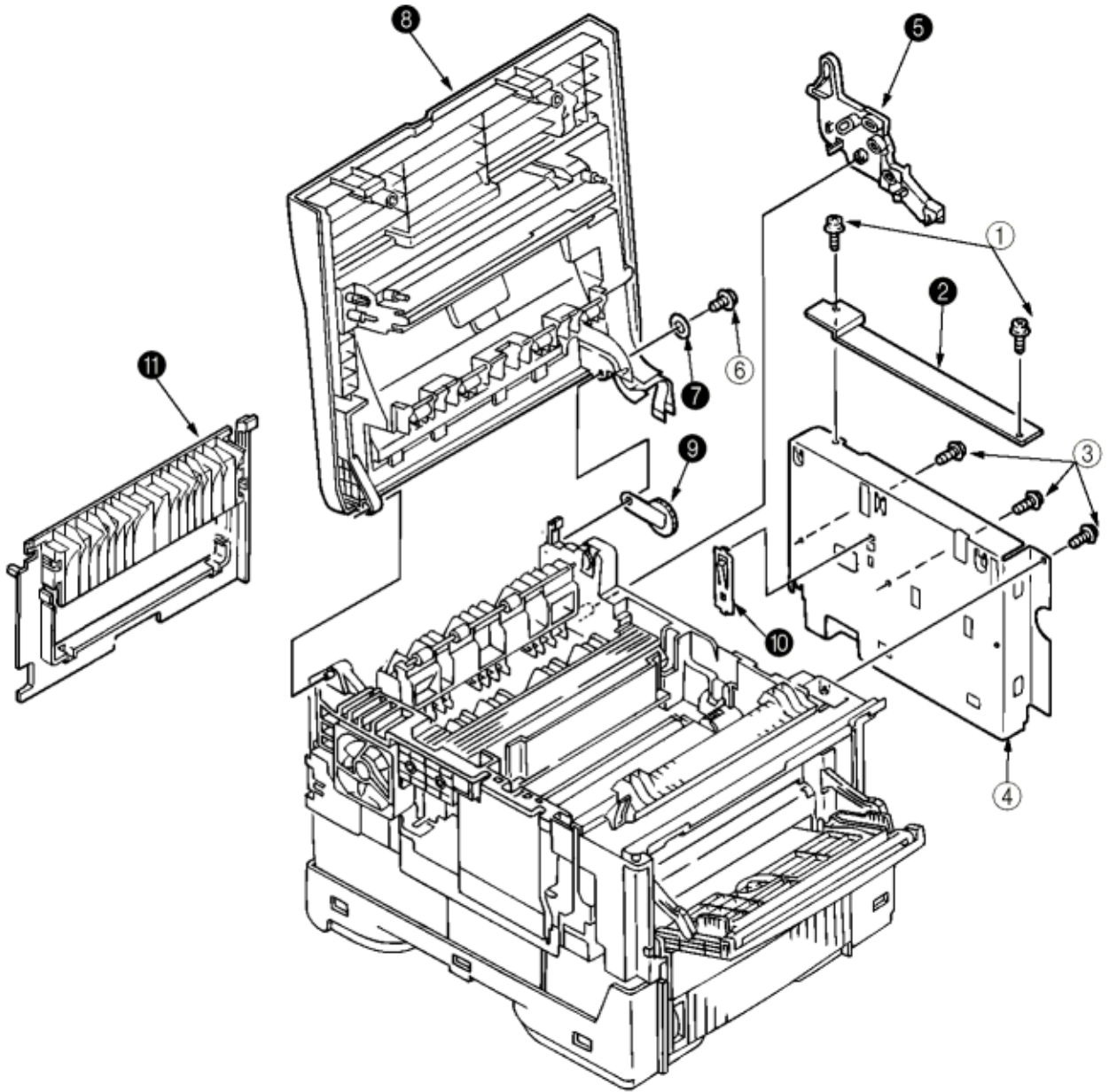

Copyright 1998, Okidata, Division of OKI America, Inc. All rights reserved. See the OKIDATA Business Partner Exchange (BPX) for any updates to this material. (<http://bpx.okidata.com>)



3.3.7 Sensor Stacker Full

- (1) Turn the AC power switch off. Unplug the AC power cord from the outlet.
- (2) Remove the Stacker assy. [See 3.3.6]
- (3) Remove four screws (1). Remove stacker mount 2 by releasing the tabs at position (2A) .
- (4) Remove Sensor stacker full (3) by spreading the plastic tabs on each side of sensor Assy (3) and lifting switch from cover.

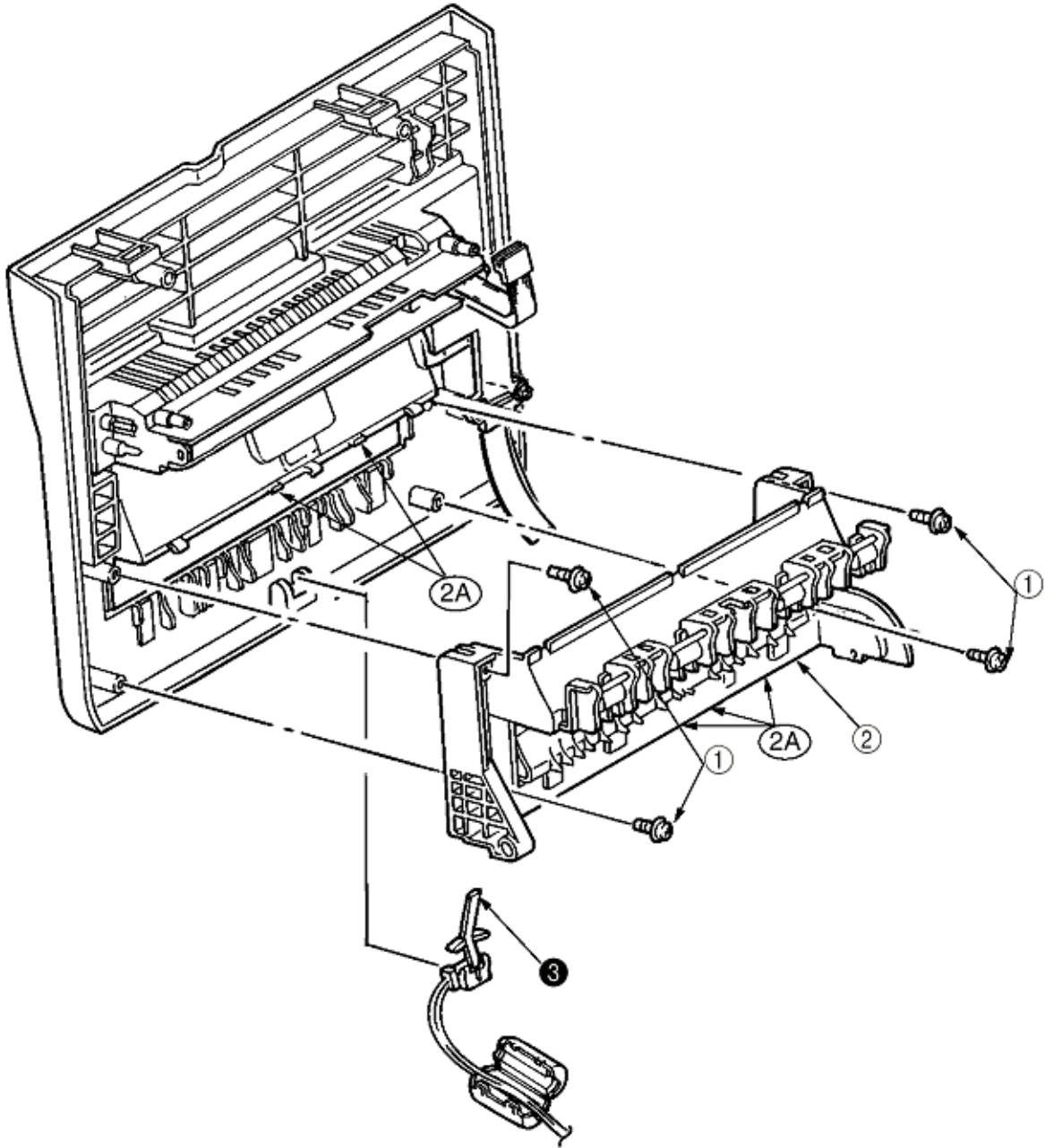

Copyright 1998, Okidata, Division of OKI America, Inc. All rights reserved. See the OKIDATA Business Partner Exchange (BPX) for any updates to this material. (<http://bpx.okidata.com>)

3.3.8 Cable cover (guide film)

- (1) Turn the AC power switch off. Unplug the AC power cord from the outlet.
- (2) Remove the stacker Assy. [See 3.3.6]
- (3) Unscrew 2 screws (1) release tabs at portion (1A) . Remove cable cover 2, guide film (3).

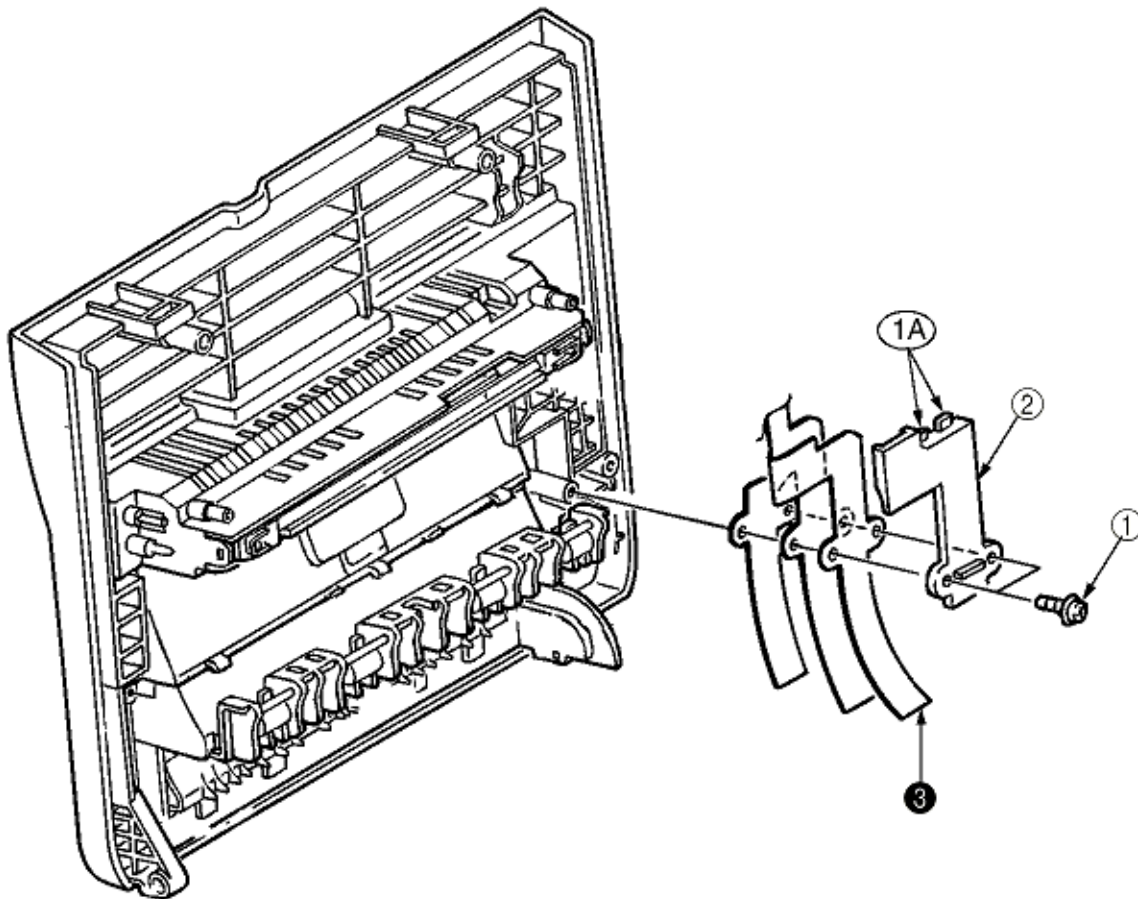

Note: Use care when replacing cable cover. Do not pitch, crimp, or cut cables or protective sheet.

3.3.9 Damper

- (1) Remove the damper arm. [See 3.3.6]
- (2) Unscrew 2 screws (1) and remove the two dampers (2).

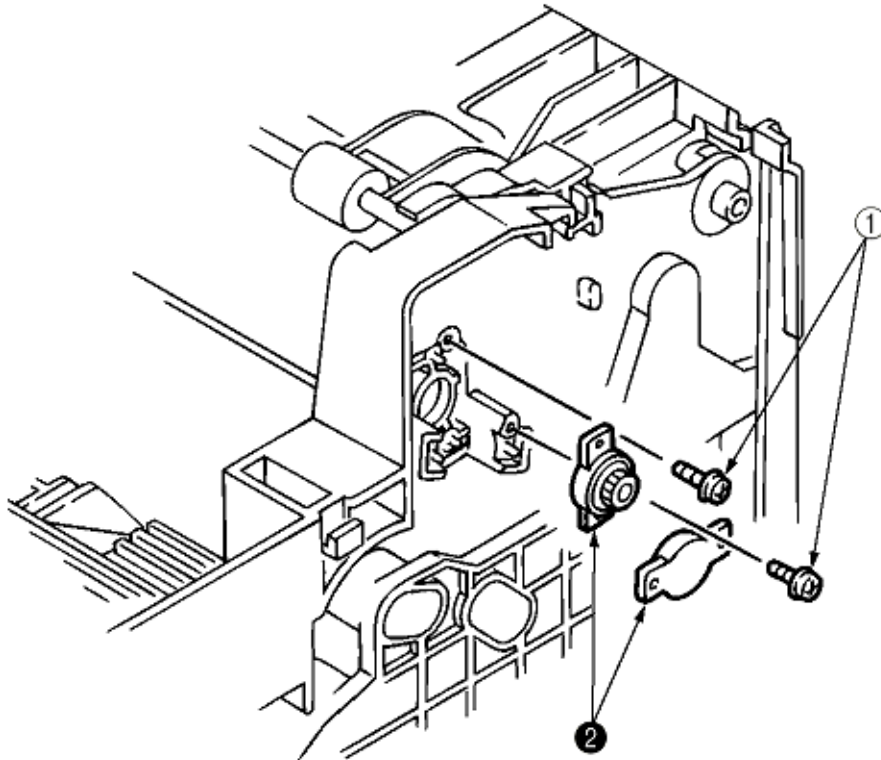



Service Guide OKIPAGE 18/18n

Chapter 3 Parts Replacement

3.3.10 Feeder Unit - Front

- (1) Open the manual feed assy (1) and release both right and left parts by pulling out the engagements on the lower part.
- (2) Stand the manual feed assy (1) on end and unhook the engagements with both right and left manual feed hopper stays.
- (3) Remove the OP panel assy. [See 3.3.4]
- (4) Unscrew 5 screws (2) and remove the feeder unit-front (3).

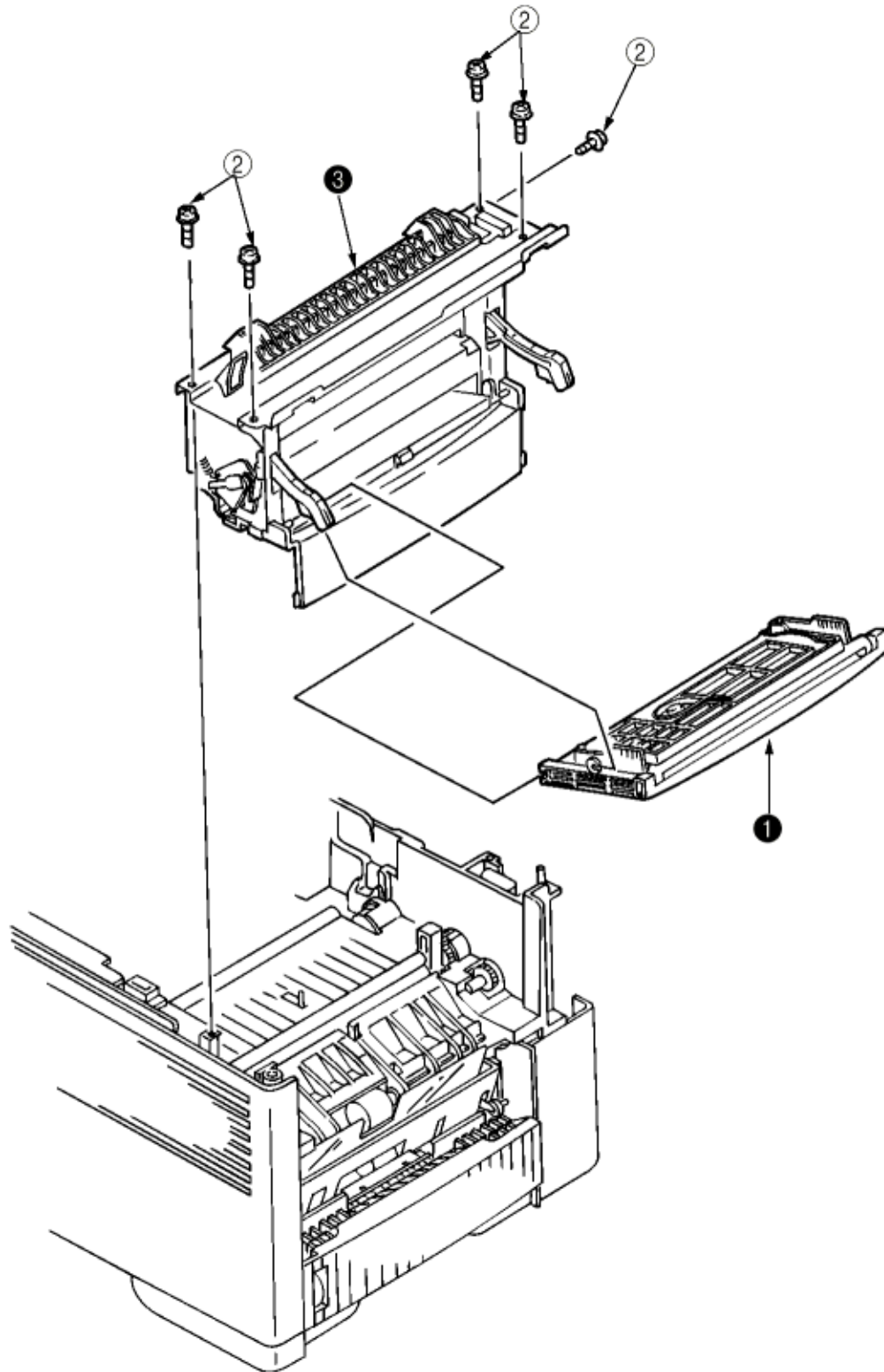

Exchange (BPX) for any updates to this material. (<http://bpx.okidata.com>)



3.3.11 Roller Assy - Regist

(1) Remove the feeder unit-front. [See 3.3.10]

(2) Remove an E-ring (3), gear assy-clutch (4), and four screws (1) in this order, and lift out the roller assy-registration (2).

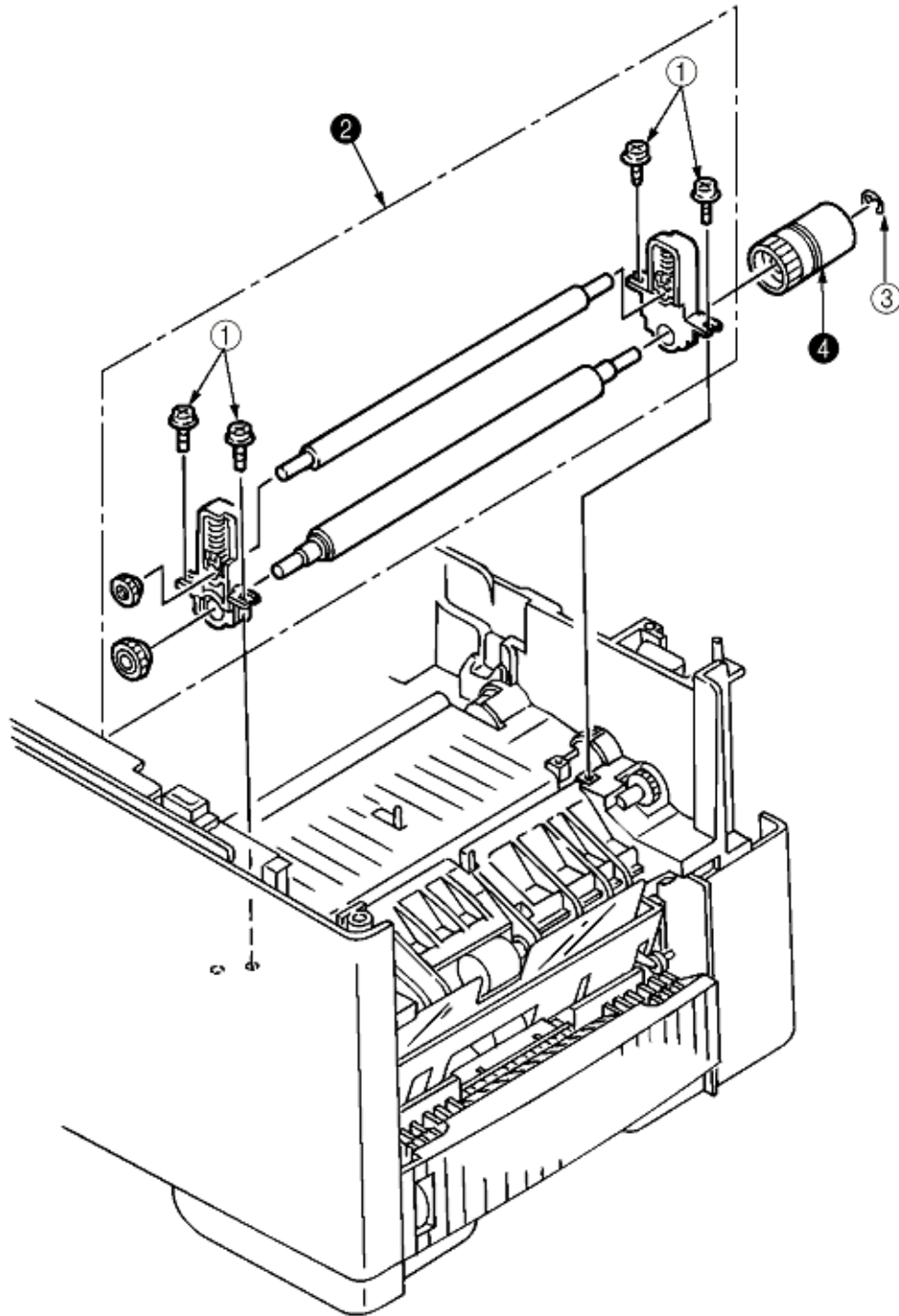

Copyright 1998, Okidata, Division of OKI America, Inc. All rights reserved. See the OKIDATA Business Partner Exchange (BPX) for any updates to this material. (<http://bpx.okidata.com>)

3.3.12 Motor - Main

- (1) Remove the stacker assy. [See 3.3.6]
- (2) Remove the feeder unit-front. [See 3.3.10] (At this point, the manual feed assy does not have to be removed.)
- (3) Remove the DC fan motor. [See 3.3.3]
- (4) Remove the contact assy. [See 3.3.2]
- (5) Remove the plate-FG (F) (1).
- (6) Remove the TR gear **(2)** and roller transfer **(3)**. (Use Holder-TR Eject (16) for the removal.)
- (7) Unscrew 7 screws (4) and remove the main frame **(5)**.
- (8) Unlock latches at two points of the lever back up release 6 and pull it out in right direction.
- (9) Unhook the EP lock spring (7) and remove the EP lock lever **(8)**.
- (10) Take off the E ring (9) and remove the plate-FG (1st) (10) and gear assy-clutch **(11)**.
- (11) Unlock 2 latches to remove the motor assy-main **(12)** and idle gear **(13)**.
- (12) Unscrew 2 screws (14) and remove the motor -main **(15)** .

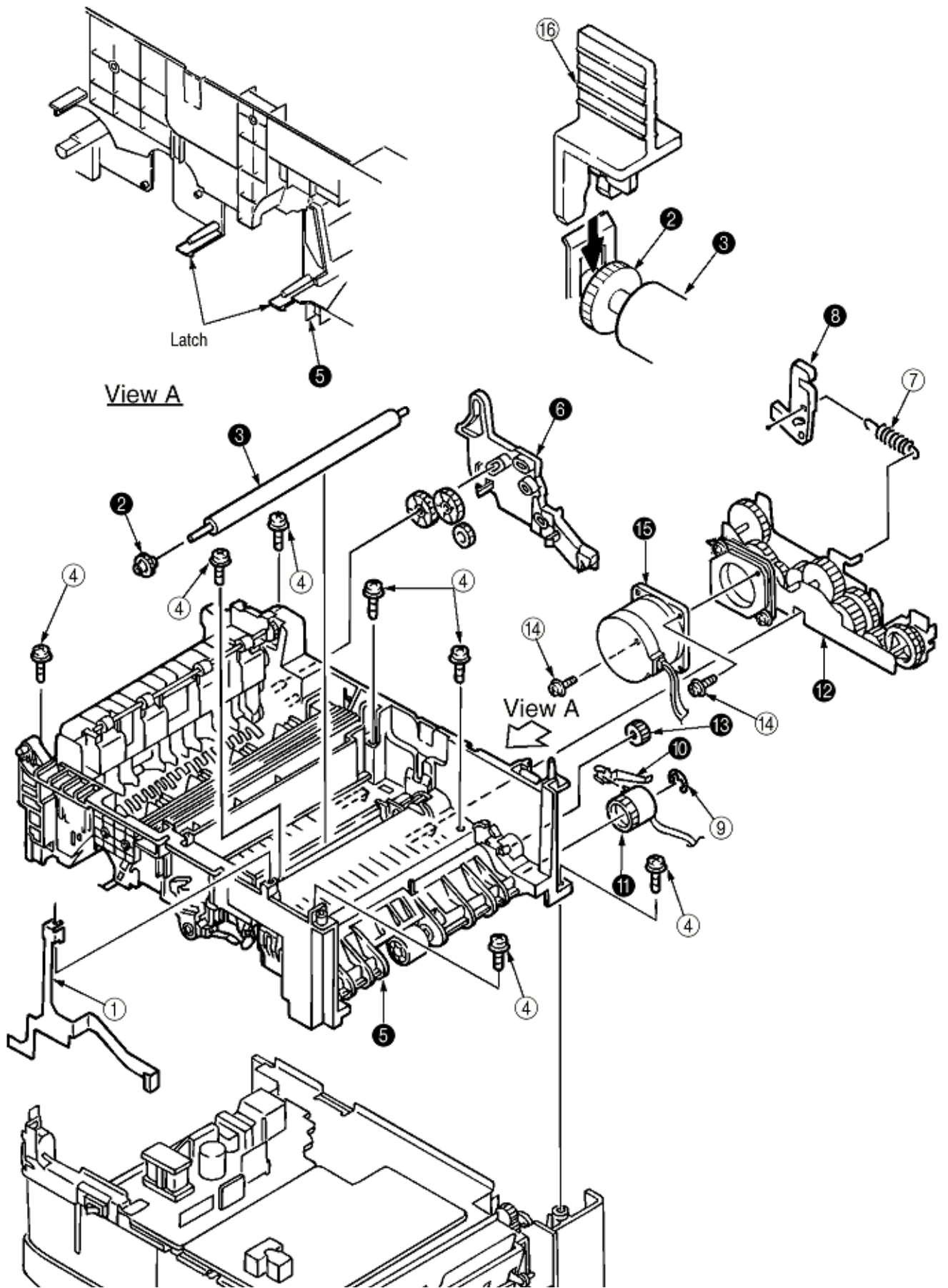

Copyright 1998, Okidata, Division of OKI America, Inc. All rights reserved. See the OKIDATA Business Partner Exchange (BPX) for any updates to this material. (<http://bpx.okidata.com>)



3.3.13 Guide Assy - Eject

- (1) Remove the lever back up release. [See 3.3.12(8)] (But the roller transfer/feeder unit front/plate-FG do not have to be removed)
- (2) Loosen 2 screws (1), unlock both side latches and remove the cover rear (2). [See 3.3.6(5)]
- (3) Unlock the latches on both sides of the guide assy-eject (3) and lift it out.

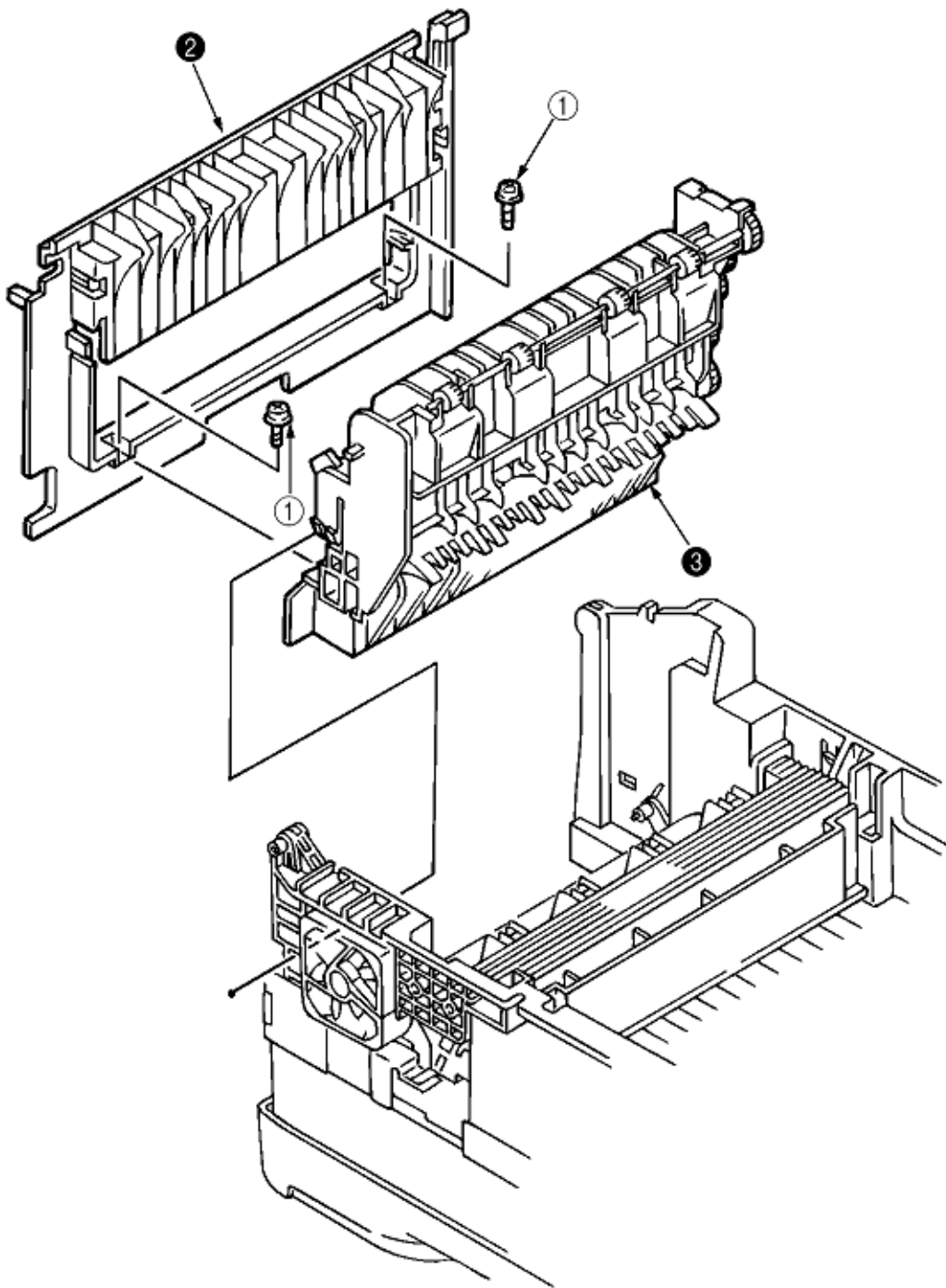

Copyright 1998, Okidata, Division of OKI America, Inc. All rights reserved. See the OKIDATA Business Partner Exchange (BPX) for any updates to this material. (<http://bpx.okidata.com>)



Service Guide OKIPAGE 18/18n

Chapter 3 Parts Replacement

3.3.14 Heat Assy

- (1) Remove the cover assy-side (L). [See 3.3.2 (1)]
- (2) Unplug the connectors (1), (2).
- (3) Unscrew 4 screws (3) and remove the heat assy (4) in the direction of the arrow by lifting the right side first.

Note !

- As the heat assy (4) remains at high temperature soon after the power is turned off, start the work after it cools off sufficiently.
- Carry out a reset of the counter after the replacement. (See Section 4.2)

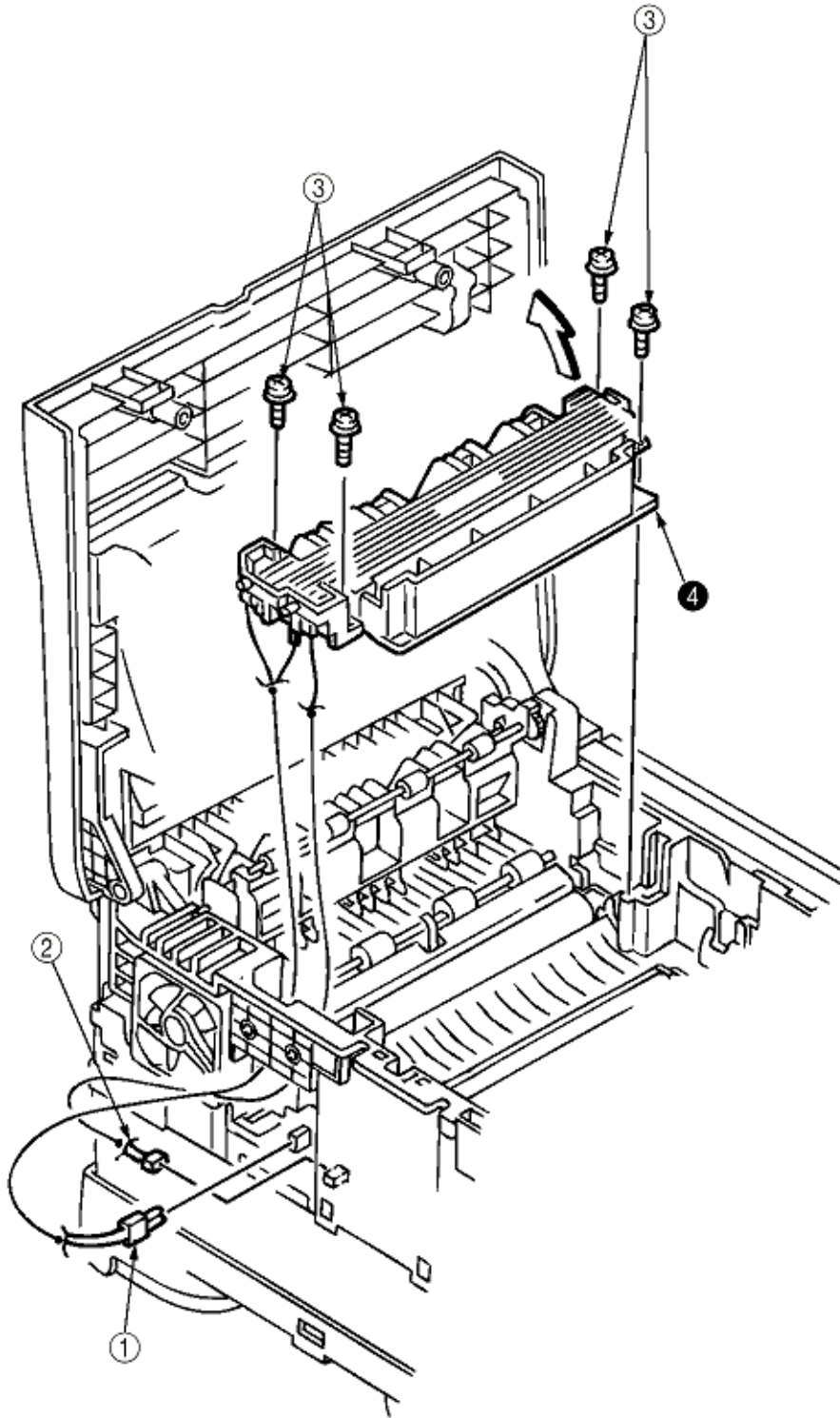

Copyright 1998, Okidata, Division of OKI America, Inc. All rights reserved. See the OKIDATA Business Partner Exchange (BPX) for any updates to this material. (<http://bpx.okidata.com>)



Service Guide OKIPAGE 18/18n

Chapter 3 Parts Replacement

3.3.15 Roller feed (C)

(1) Remove the guide assy-eject. (See 3.3.13)

(But roller transfer/feeder unit-front/plate-FG(F) do not have to be removed)

(2) Remove the gear roller (C) **(1)** and bushing **(2)**, bend (a) part of the plate-FG (BK) **(3)**. Take off the carrier bearing **(4)** and remove the roller feed (c) **(5)** in the direction of the arrow.

Note ! Be careful not to deform (a) part of the plate-FG (BK) **(3)**.

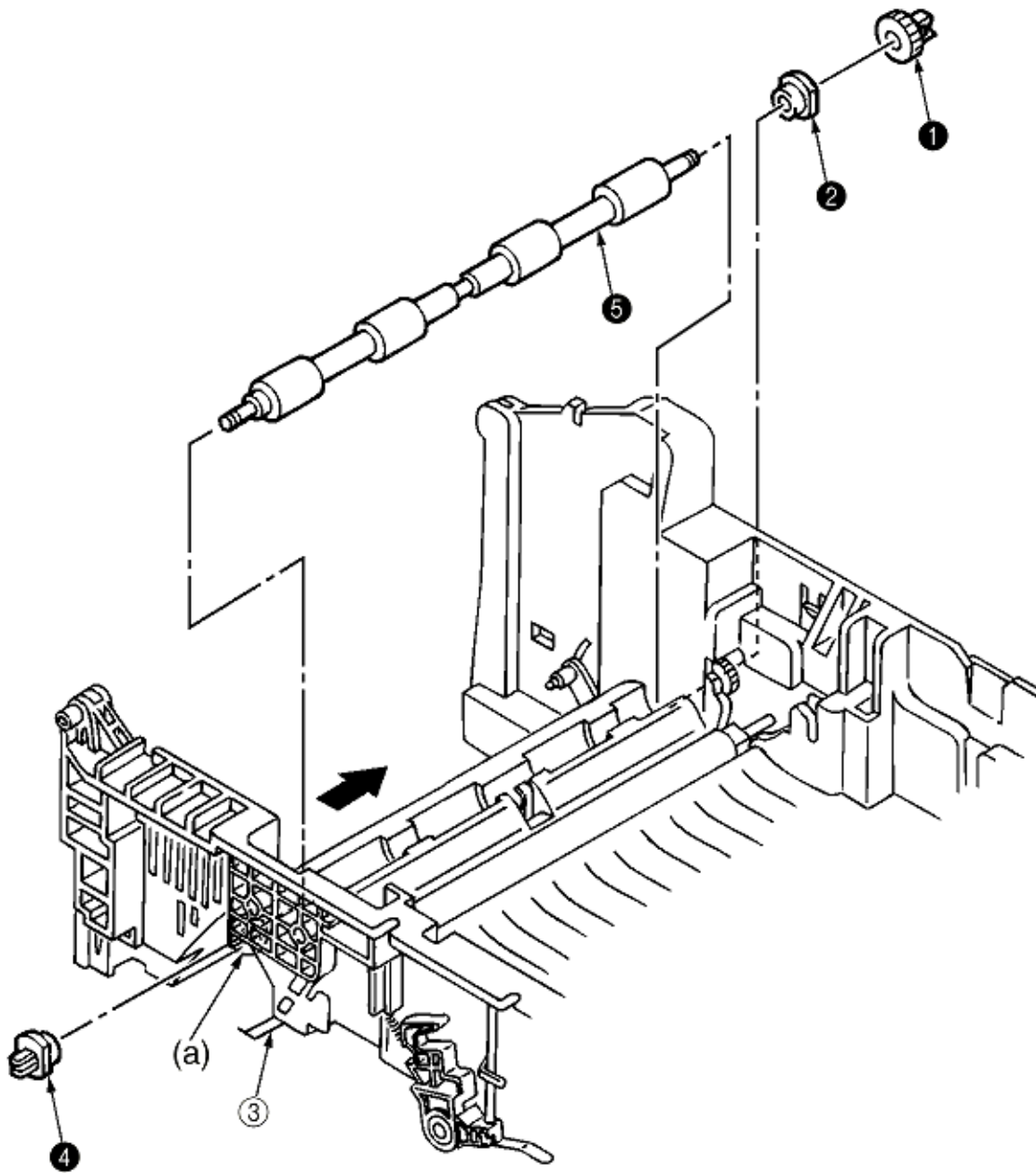

Copyright 1998, Okidata, Division of OKI America, Inc. All rights reserved. See the OKIDATA Business Partner Exchange (BPX) for any updates to this material. (<http://bpx.okidata.com>)



3.3.16 Roller Assy - BK

- (1) Remove the heat Assy. [See 3.3.14]
- (2) Remove the lever back up release. [See 3.3.12 (8)]
- (3) Unlock the engagement with the plate-FG (BK) (1) and lift out the roller heat assy (2).

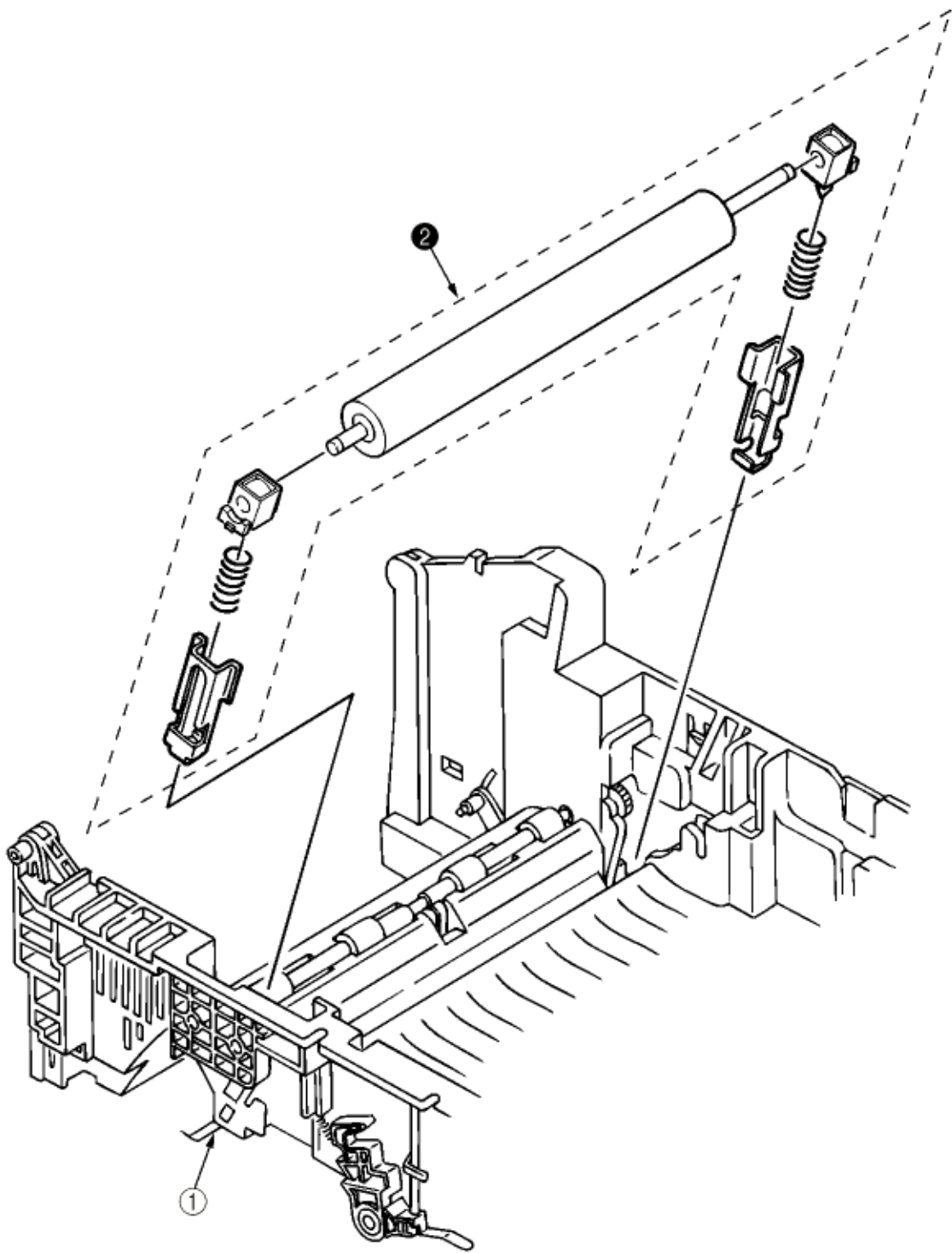

3.3.17 Roller Assy - Feed

- (1) Remove the feeder unit -front. [See 3.3.10]
- (2) Remove the roller assy-feed (1) by unlocking a latch.

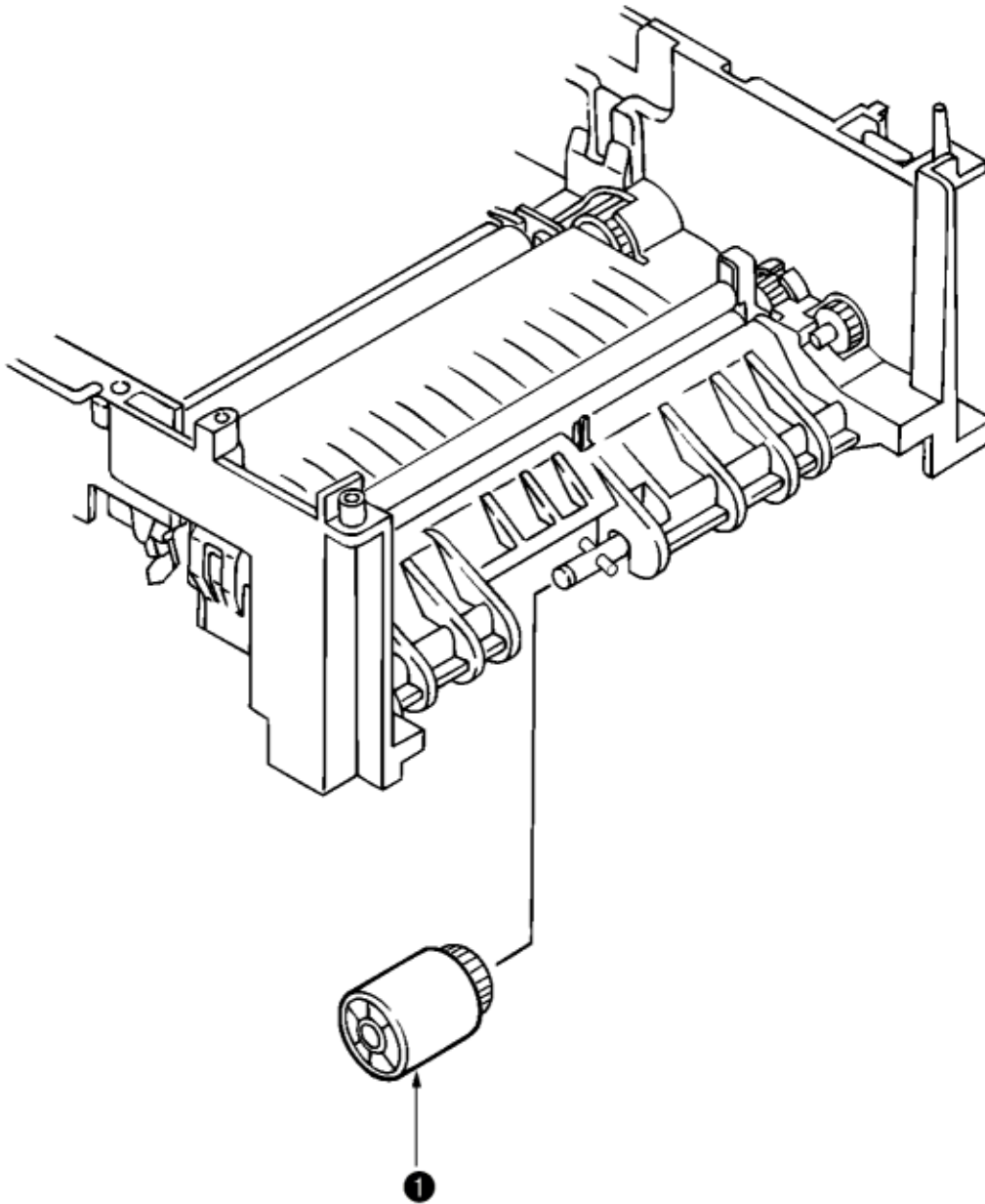

Exchange (BPX) for any updates to this material. (<http://bpx.okidata.com>)

3.3.18 LED Head

- (1) Remove the stacker assy (1). [See 3.3.6]
- (2) Unplug the PC connector (2) and 2 LED cables (3) from the LED head (4).
- (3) Open the hooks of the cover stacker 1 in the direction of the arrow and remove the LED head (4).
- (4) Pull out the head spring (5) from the post.

Note: Don't remove two LED cable (3) from the PC connector (2).

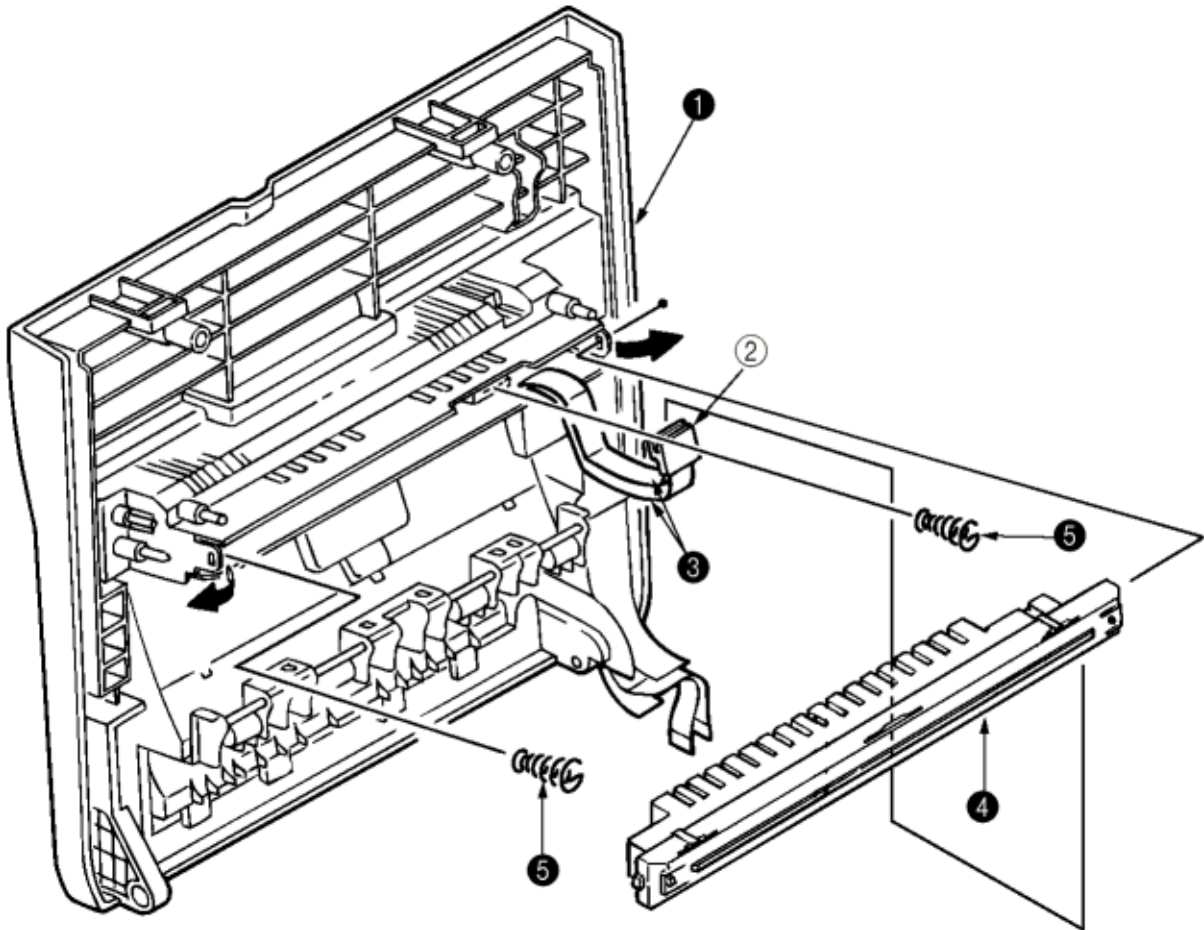

3.3.19 Paper cassette, ROLLER Assy - Feed, ROLLER Assy - Hopping

- (1) Pull out the case assy-cassette (1) from the printer.
- (2) Remove the ROLLER Assy-Feed (2) and remove the ROLLER Assy-Hopping (3).

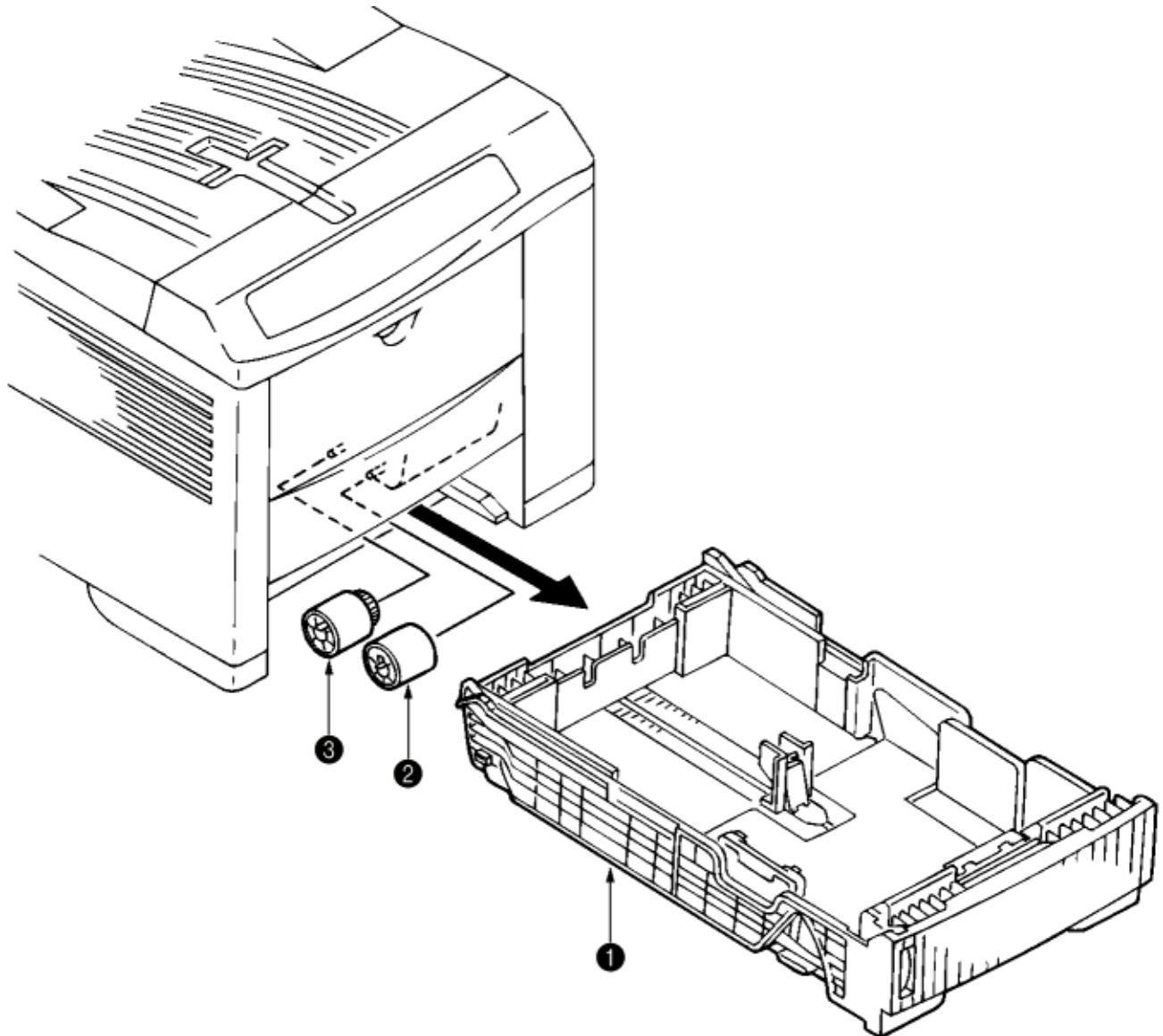

Exchange (BPX) for any updates to this material. (<http://bpx.okidata.com>)



3.3.20 Frame Assy - Separation

- (1) Turn the AC power switch off. Unplug the AC power cord from the outlet.
- (2) Pull out the case Assy-Cassette **(1)** from the printer. [See 3.3.19(1)]
- (3) Release two locks and remove frame assy-separation **(2)**. (At this time, coil spring 3 is also removed. Be careful not to lose this spring.)

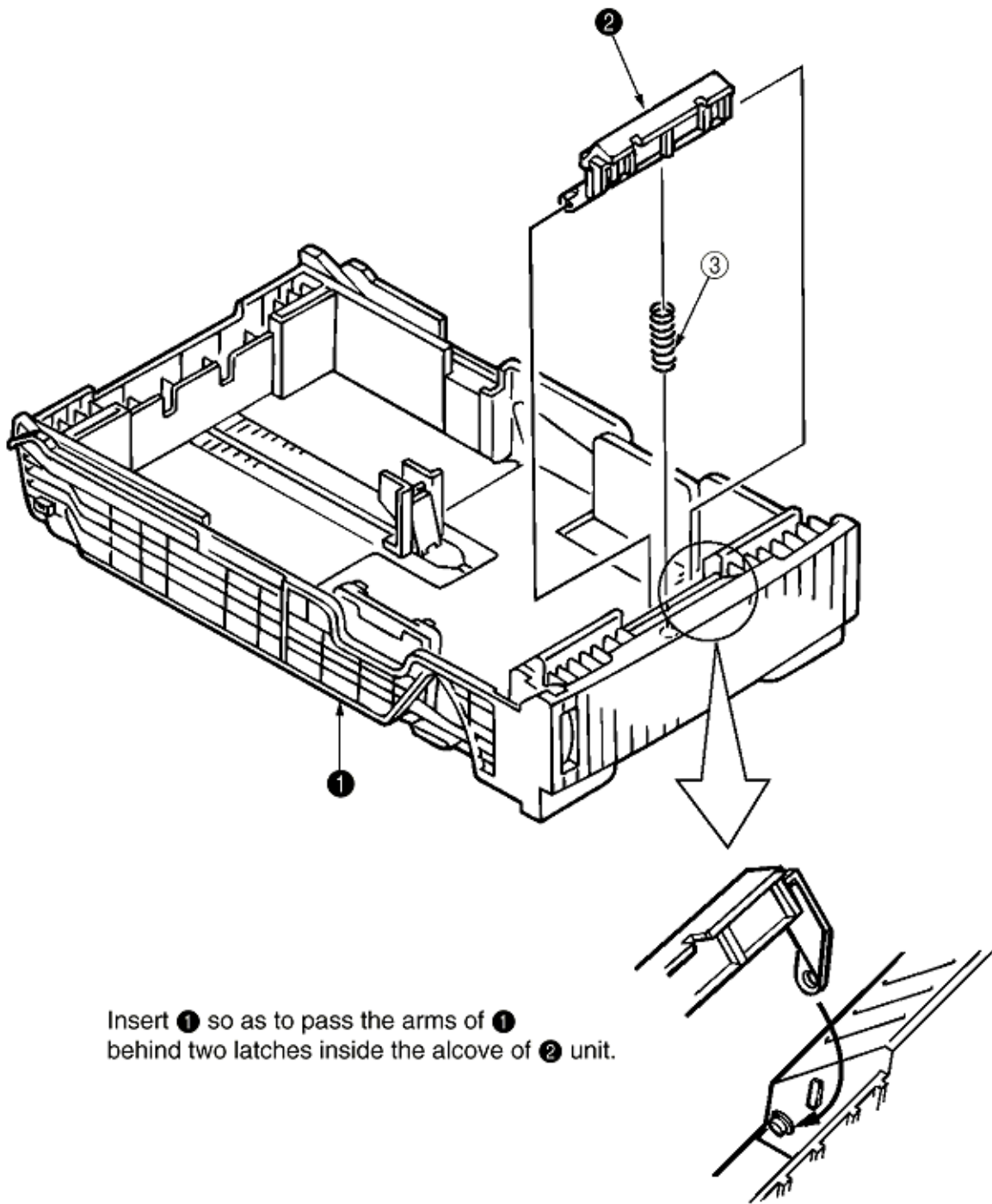

Insert **1** so as to pass the arms of **1** behind two latches inside the alcove of **2** unit.



Service Guide OKIPAGE 18/18n

Chapter 3 Parts Replacement

3.3.21 Transfer Roller / TR Gear / TR Bearing

(1) Open the stacker cover .

(2) Unlock the lock by lifting the TR gear **(1)** to remove the TR gear **(1)** and roller transfer **(2)**. (Use the Holder-TR Eject **(5)** for the removal.)

Note ! Don't place the removed roller transfer directly on the desk and so on. When placing it, lay a paper and the like under it.

(3) Remove right and left bearings **(3)** from the frame-main by sliding them inside while pushing them. At the same time, remove the 2 transfer springs **(4)**.

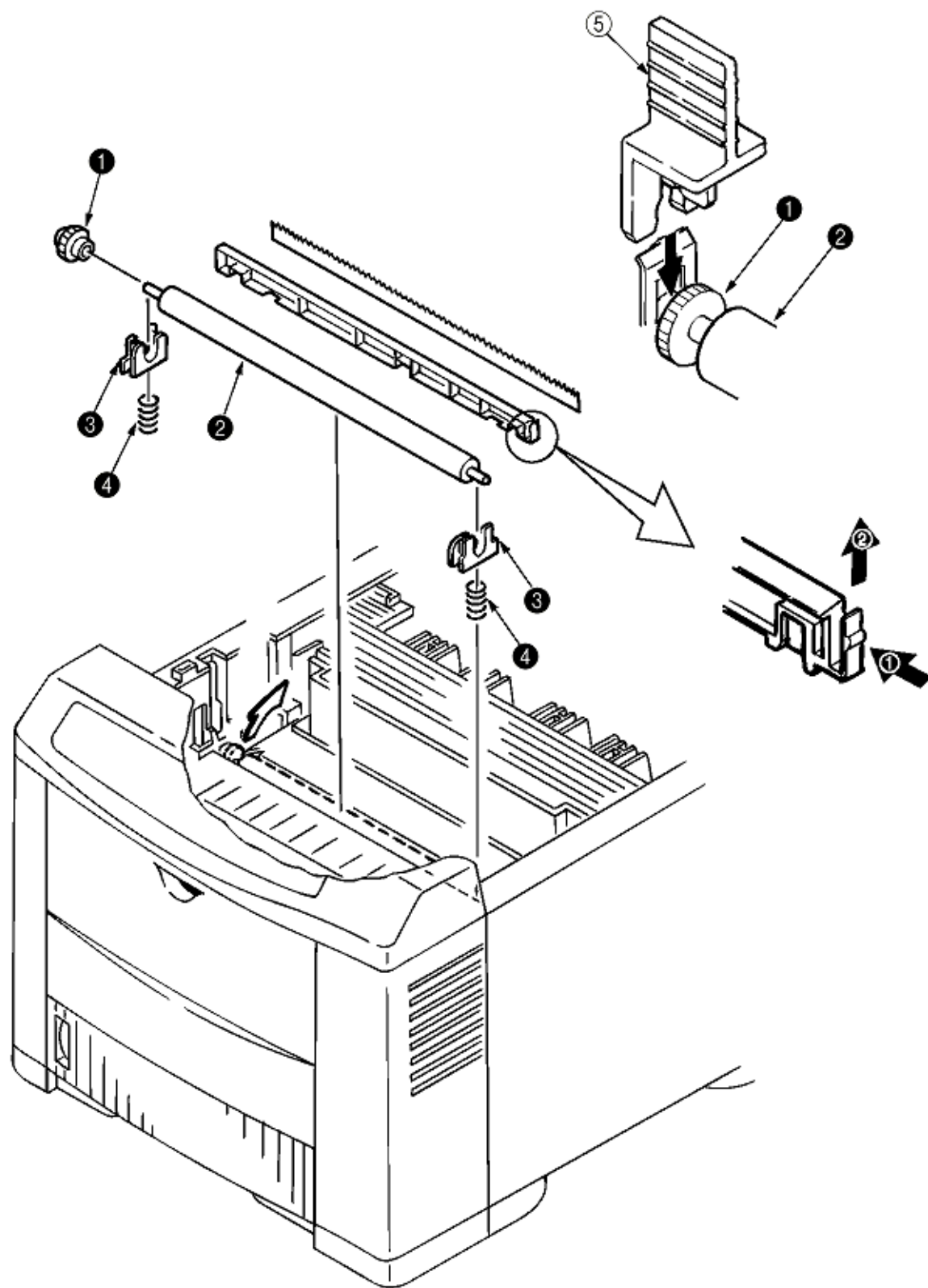

Copyright 1998, Okidata, Division of OKI America, Inc. All rights reserved. See the OKIDATA Business Partner Exchange (BPX) for any updates to this material. (<http://bpx.okidata.com>)

3.3.22 EP lock shaft

- (1) Turn the AC power switch off. Unplug the AC power cord from the outlet.
- (2) Remove Frame-Main [See 3.3.12 (7)].
- (3) Remove screw (1). Turn EP lock lever (L) Assy (2) in the direction of arrow (A) .
- (4) Remove spring (3).
- (5) Drop EP lock shaft (4) down and turn in the direction of arrows (B) and remove it.

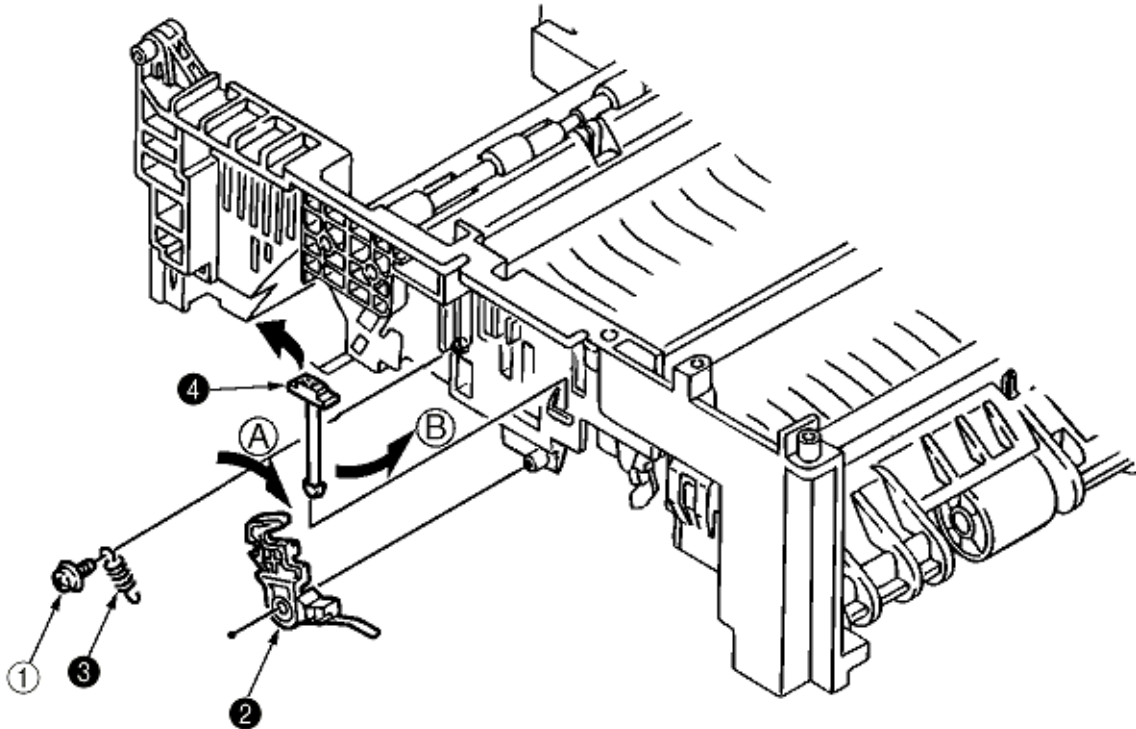



3.3.23 LEVER Assy - Out Sensor

- (1) Turn the AC power switch off. Unplug the AC power cord from the outlet.
- (2) Remove the frame main [See 3.3.12(7)]
- (3) Press the clamp part of LEVER Assy- Out Sensor **(1)**. Remove the LEVER Assy-Out Sensor **(1)** by pushing it upward from the lower side.

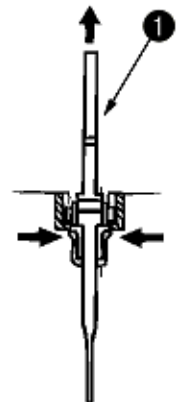
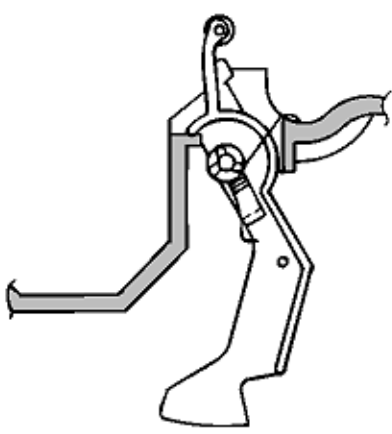
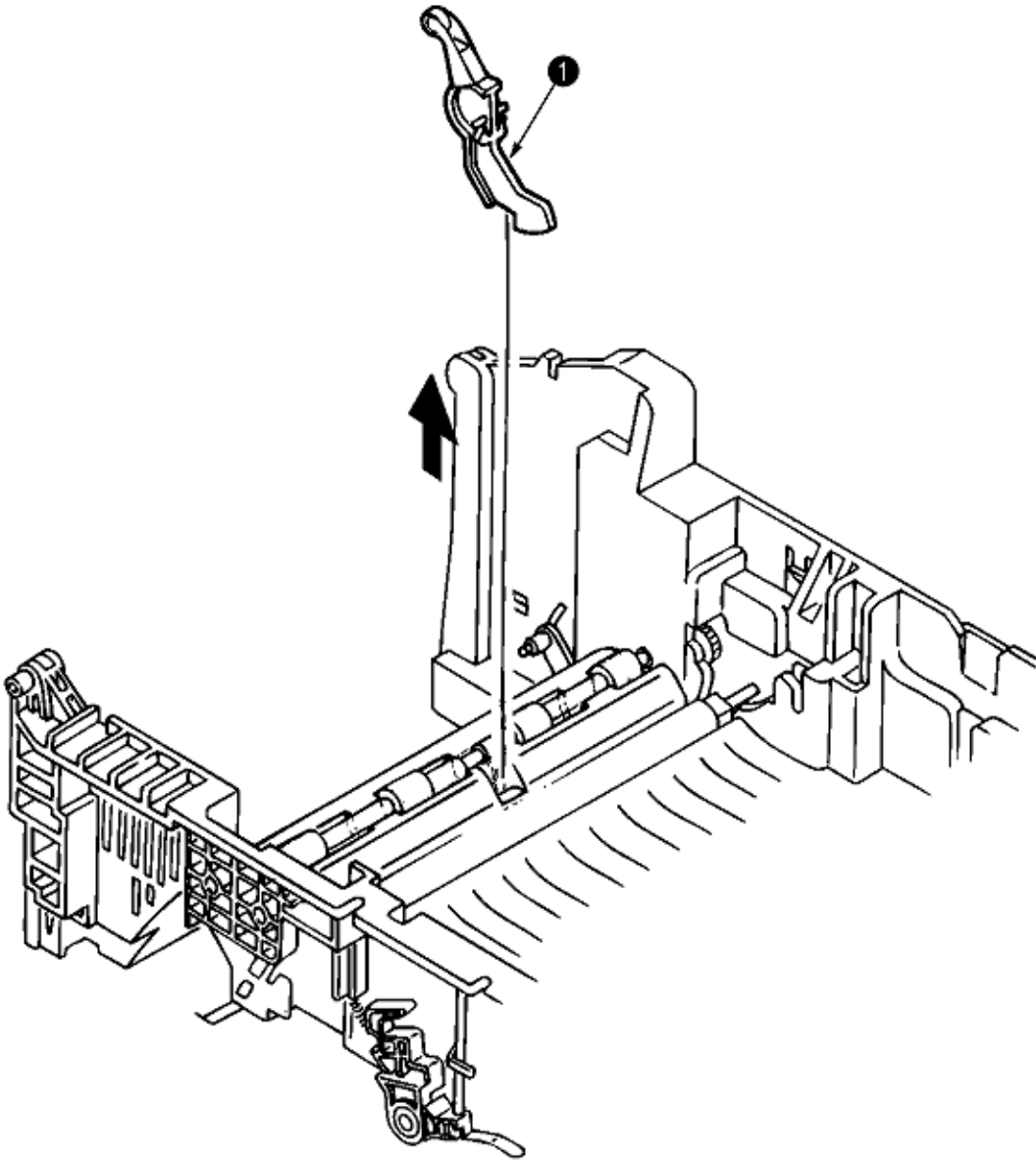

Copyright 1998, Okidata, Division of OKI America, Inc. All rights reserved. See the OKIDATA Business Partner Exchange (BPX) for any updates to this material. (<http://bpx.okidata.com>)



3.3.24 Toner sensor lever

- (1) Turn the AC power switch off. Unplug the AC power cord from the outlet.
- (2) Remove the frame main [See 3.3.12(7)]
- (3) Squeeze the clamp part of toner sensor lever **(1)** and remove the toner sensor lever **(1)** by pushing it upward from the lower side.

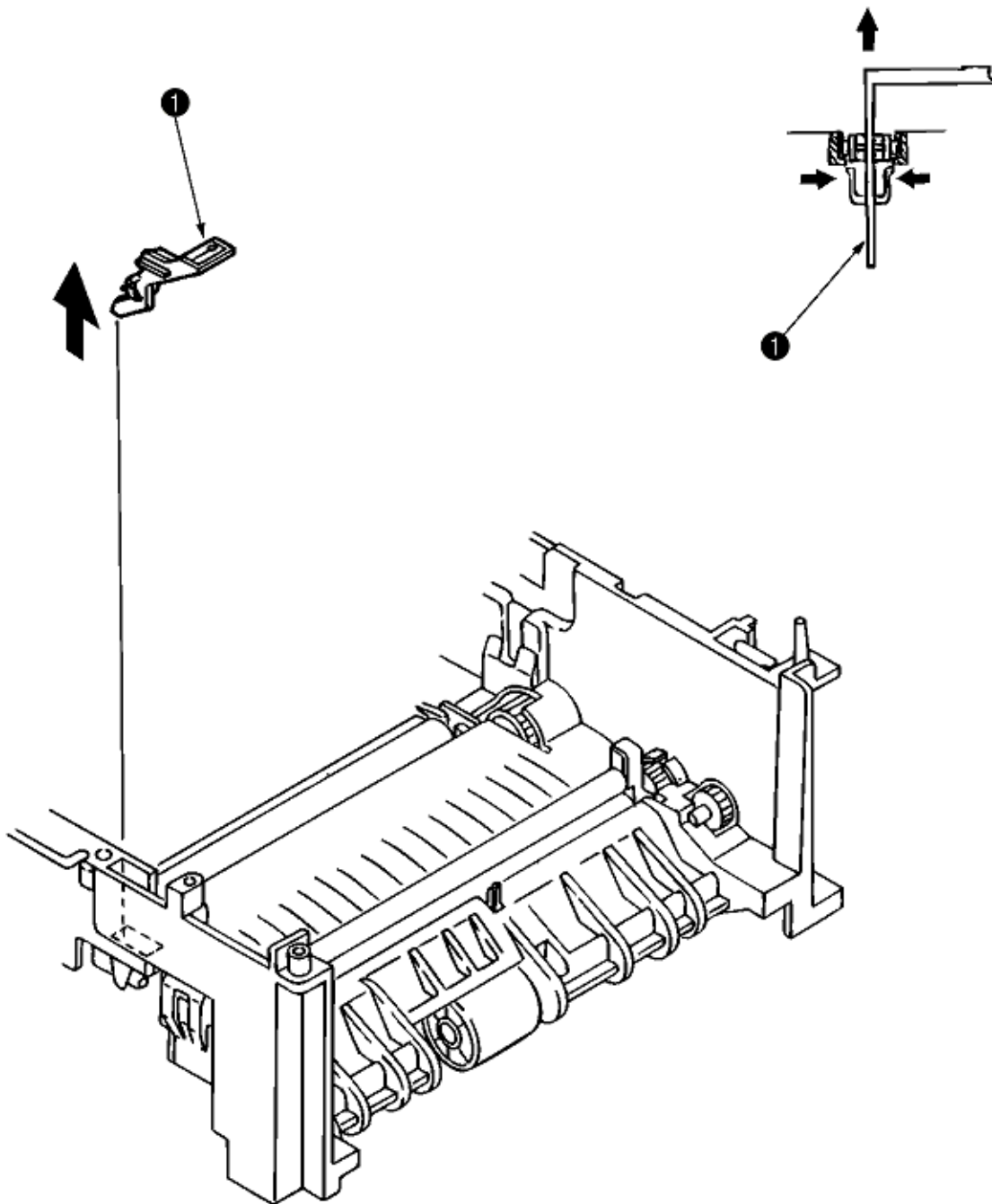

Copyright 1998, Okidata, Division of OKI America, Inc. All rights reserved. See the OKIDATA Business Partner Exchange (BPX) for any updates to this material. (<http://bpx.okidata.com>)

3.3.25 Paper sensor lever

- (1) Turn the AC power switch off. Unplug the AC power cord from the outlet.
- (2) Remove the frame main [See 3.3.12(7)]
- (3) Squeeze the clamp part of the paper sensor lever (1) and remove the paper sensor lever (1) by pushing it upward from the lower side.

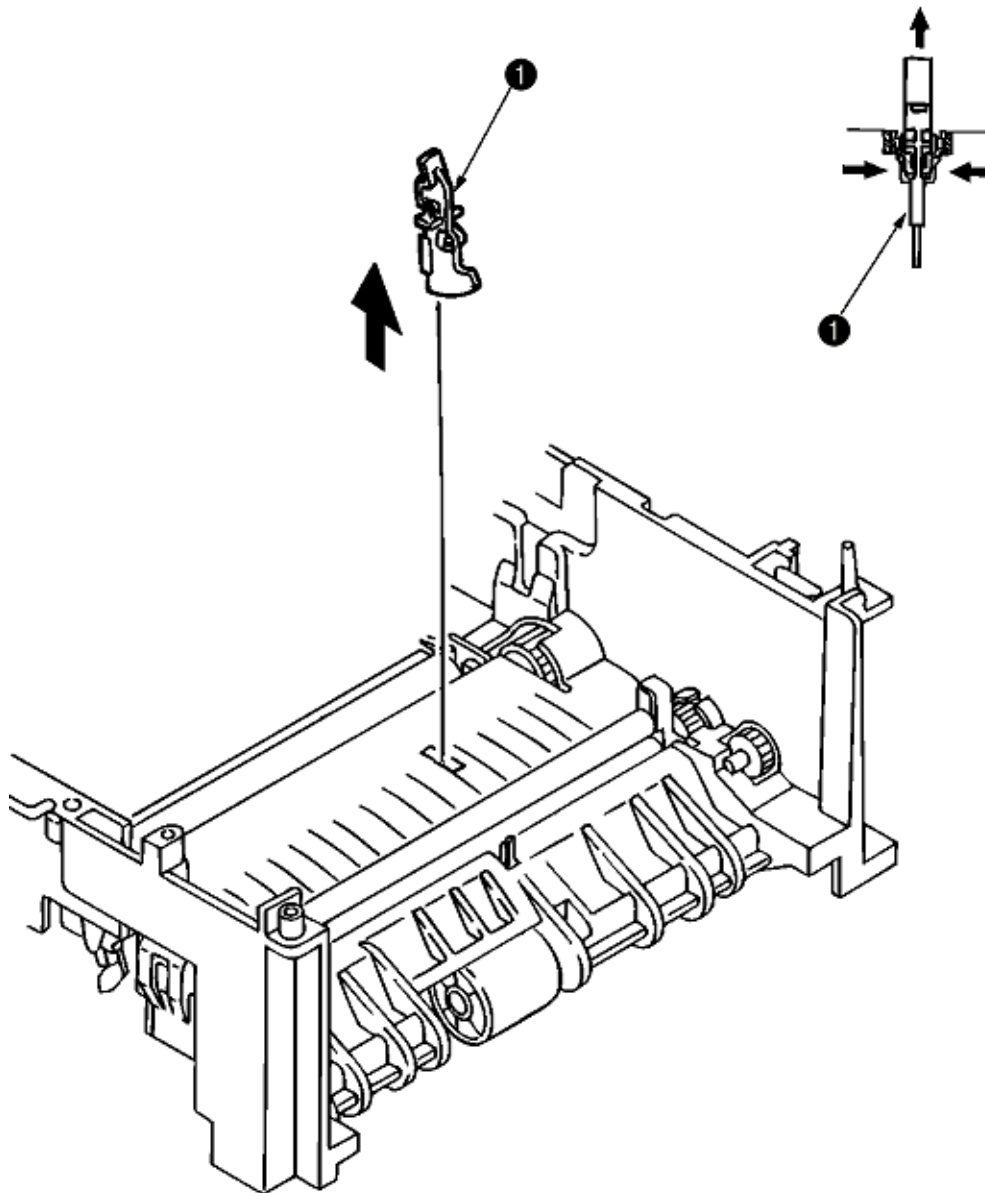

Copyright 1998, Okidata, Division of OKI America, Inc. All rights reserved. See the OKIDATA Business Partner Exchange (BPX) for any updates to this material. (<http://bpx.okidata.com>)

3.3.26 Inlet sensor lever

- (1) Turn the AC power switch off. Unplug the AC power cord from the outlet.
- (2) Remove the frame main [See 3.3.12(7)]
- (3) Squeeze the clamp part of two inlet sensor levers (1). Remove the inlet sensor levers (1) by pushing them downward.

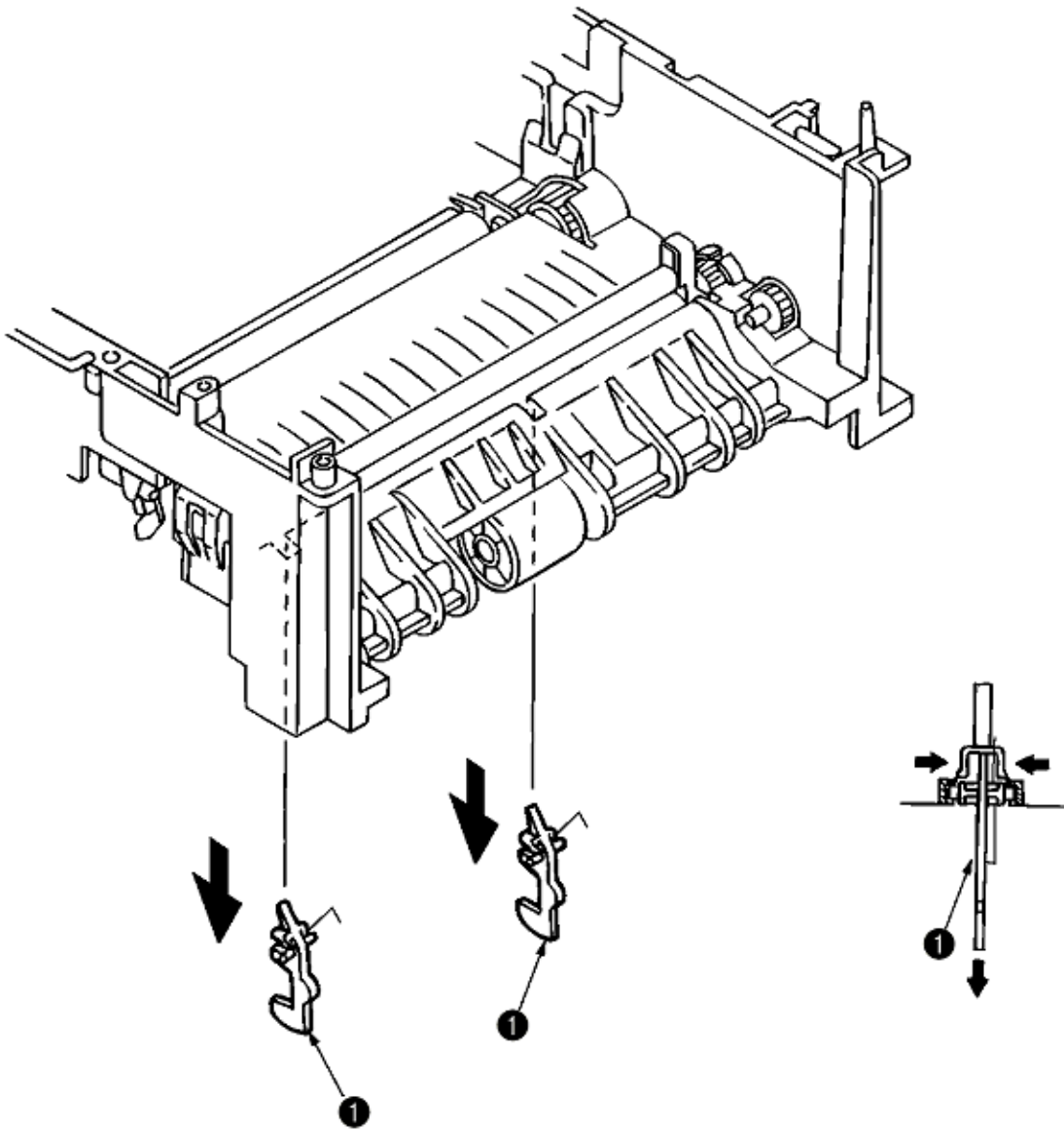

Exchange (BPX) for any updates to this material. (<http://bpx.okidata.com>)



3.3.27 Power supply unit

- (1) Turn the AC power switch off. Unplug the AC power cord from the outlet.
- (2) Remove the frame main [See 3.3.12(7)]
- (3) Unscrew 2 screws (1) and remove the BRACKET-AC (2).
- (4) Unscrew 10 screws (3) and remove the connector 6 remove the Power supply unit [AC-DC (120/230V)] (4) and Power supply unit (High voltage) (5).

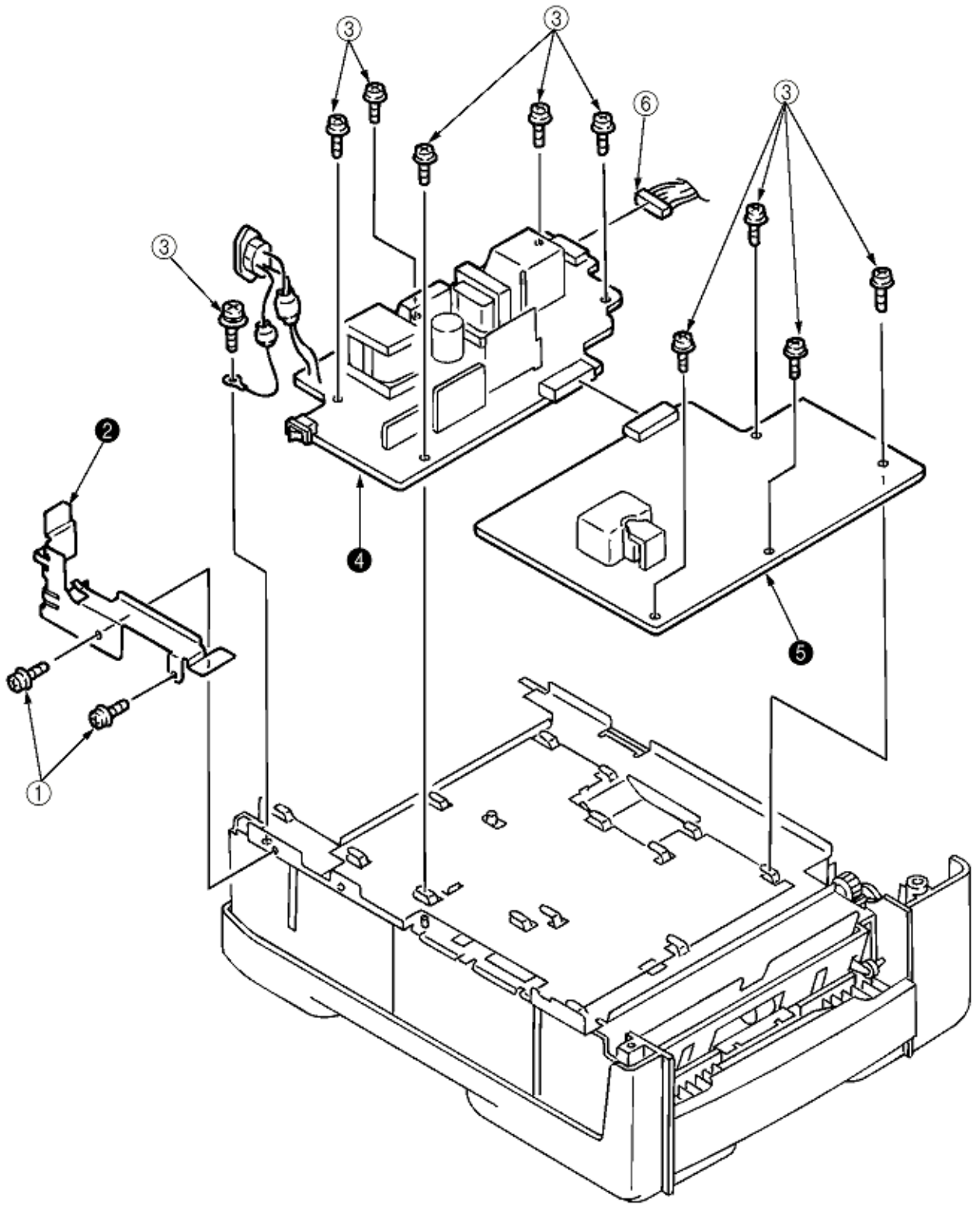

Copyright 1998, Okidata, Division of OKI America, Inc. All rights reserved. See the OKIDATA Business Partner Exchange (BPX) for any updates to this material. (<http://bpx.okidata.com>)

Service Guide OKIPAGE 18/18n

Chapter 3 Parts Replacement

3.3.28 Lever-Paper end & Lever-Paper near end

- (1) Turn the AC power switch off. Unplug the AC power cord from the outlet.
- (2) Remove the frame main [See 3.3.12(7)]
- (3) Remove screw (1) and then remove the PLATE-Base (2).
- (4) Remove two Spacer-Cord (KGPS-5RF (3) and then remove FILM-Insulation (4).
- (5) Remove four screws (5) and then remove the FRAME ASS-Hopping (6).
- (6) Remove the GEAR-Z58 (9) and GEAR-Z42 (8). (At this time, the ADF Bearing (10) can also be detached simultaneously.)
- (7) Remove the GEAR-Z38 (14), ADF Bearing (15), ROLLER-Guide (16) and SHAFT Hopping (17) and Bracket-Sub roller (28). (At this time, the Lock Pin (18) can also be detached simultaneously.)
- (8) Remove two screws (7) and then remove the SPRING-Release (11) and then remove the LEVER-Sub roller (12) and PLATE-Hopping (13).
- (9) Remove the GEAR-Planet(Z28) (19), Plate-Planet (20), BRACKET-Spring (Sub) (21) and SPRING-Sub ROLLER (22).
- (10) Press the clamp part of Lever-Paper end (23) and Lever-Paper near end (24). Remove the Lever-Paper end (23) and Lever-Paper near end (24) by pushing it upward from the FRAME Hopping (28).
- (11) Remove the Connection Cord-Wire (25) and TR-23-11-14 R CORE (26) together.
- (12) Remove two Photo Sensor (27).

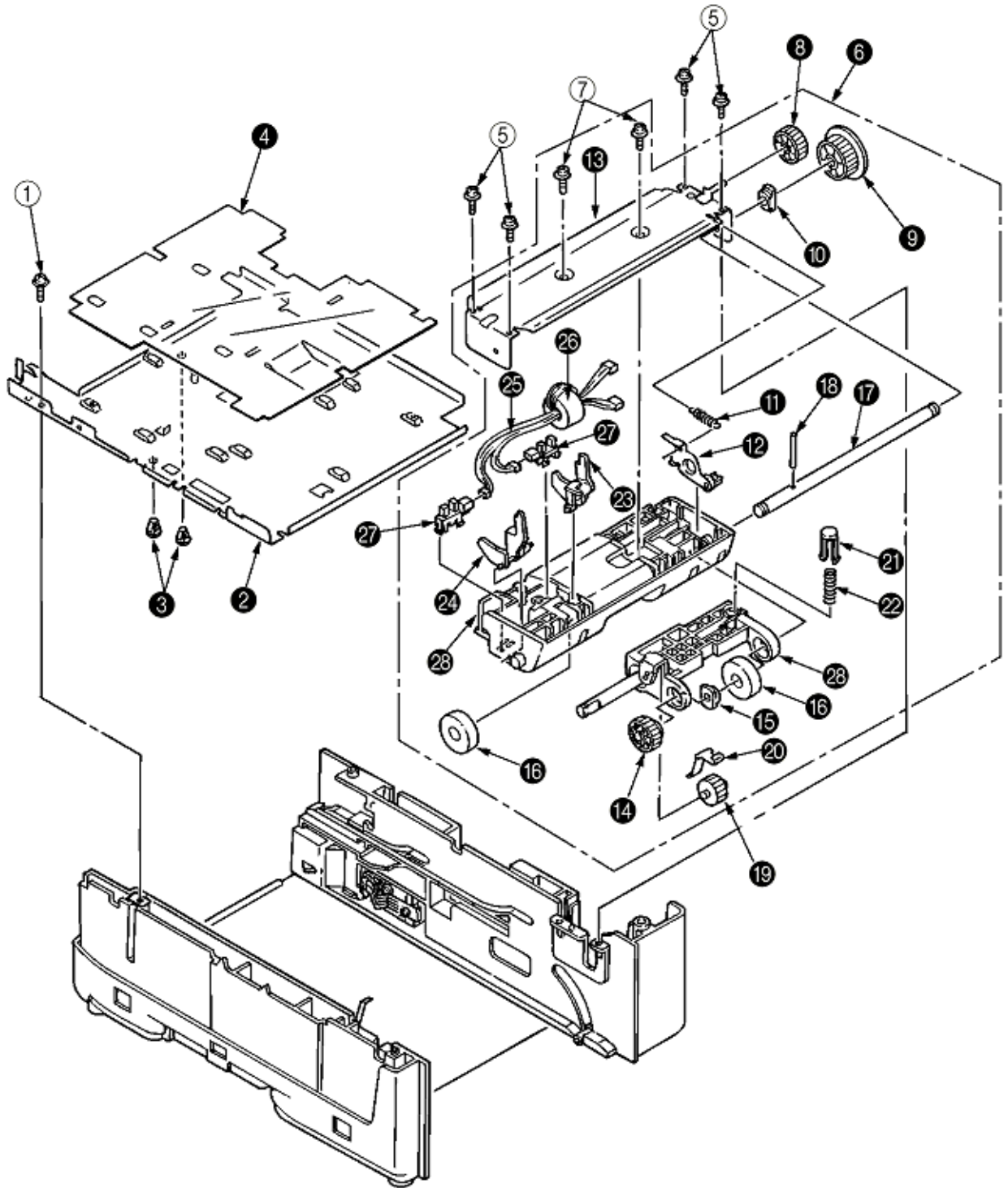

Copyright 1998, Okidata, Division of OKI America, Inc. All rights reserved. See the OKIDATA Business Partner Exchange (BPX) for any updates to this material. (<http://bpx.okidata.com>)



3.3.29 Guide Assy - Cassette (L)

- (1) Turn the AC power switch off. Unplug the AC power cord from the outlet.
- (2) Remove Frame Main [See 3.3.12(7)]
- (3) Remove PLATE-Base and FRAME Assy Hopping [See 3.3.28 (5)]
- (4) Unscrew two screw (1) and then remove Guide Assy-Cassette (L) (2).
- (5) Remove SPRING-Sheet (3) and then remove LINK-Sheet (4) and pull block (5). (Pay attention the direction of hook of SPRING-Sheet (3).)
- (6) Remove spring (6) and then remove cassette stopper (7).
- (7) Remove screw (8) from LINK-Sheet (4) and then remove link support (9) and Roller-link (10).
- (8) Remove Earth Plate L (11) and Plate-Earth (link) (12).

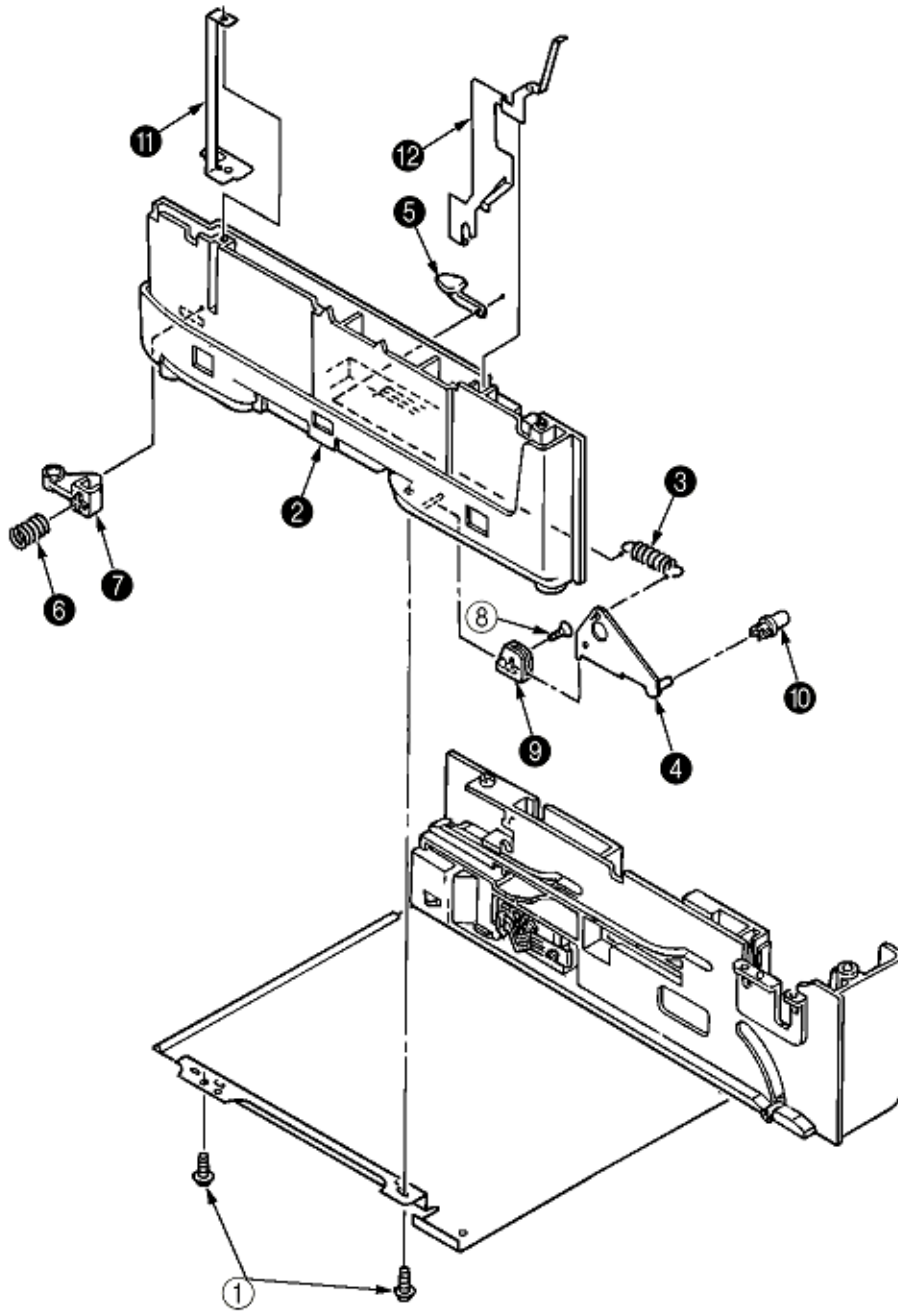

Copyright 1998, Okidata, Division of OKI America, Inc. All rights reserved. See the OKIDATA Business Partner Exchange (BPX) for any updates to this material. (<http://bpx.okidata.com>)



Service Guide OKIPAGE 18/18n

Chapter 3 Parts Replacement

3.3.30 Guide Assy - Cassette (R)

- (1) Turn the AC power switch off. Unplug the AC power cord from the outlet.
- (2) Remove Frame Main [See 3.3.12(7)]
- (3) Remove PLATE-Base and FRAME Assy Hopping [See 3.3.28 (5)]
- (4) Unscrew two screw (1) and then remove Guide Assy-Cassette (R) (2).
- (5) Remove SPRING-Sheet (3) and then remove LINK Sheet (4) and pull block (5). (Pay attention the direction of hook of SPRING-Sheet (3).)
- (6) Remove spring (6) and then remove cassette stopper (7).
- (7) Remove screw 8 from LINK-Sheet (4) and then remove link support (9) and Roller-link (10).
- (8) Unscrew two screws (11) and remove the Square shaped connector (176496-1) (12) and Nylon Connector Cord (13) and TR-23-11-R CORE (14).
- (9) Unscrew two screws (15) and remove the two Plate Earth (Bottom) (16).
- (10) Unscrew two screws (17) and remove the Square shaped connector (5-176496-1) (18) and Connection Cord Wire (19) and TR-23-11-R CORE (20).
- (11) Unscrew a screw (21) and remove the Detector spring (22).
- (12) Unscrew a screw (23) and remove the Board PXC (24).

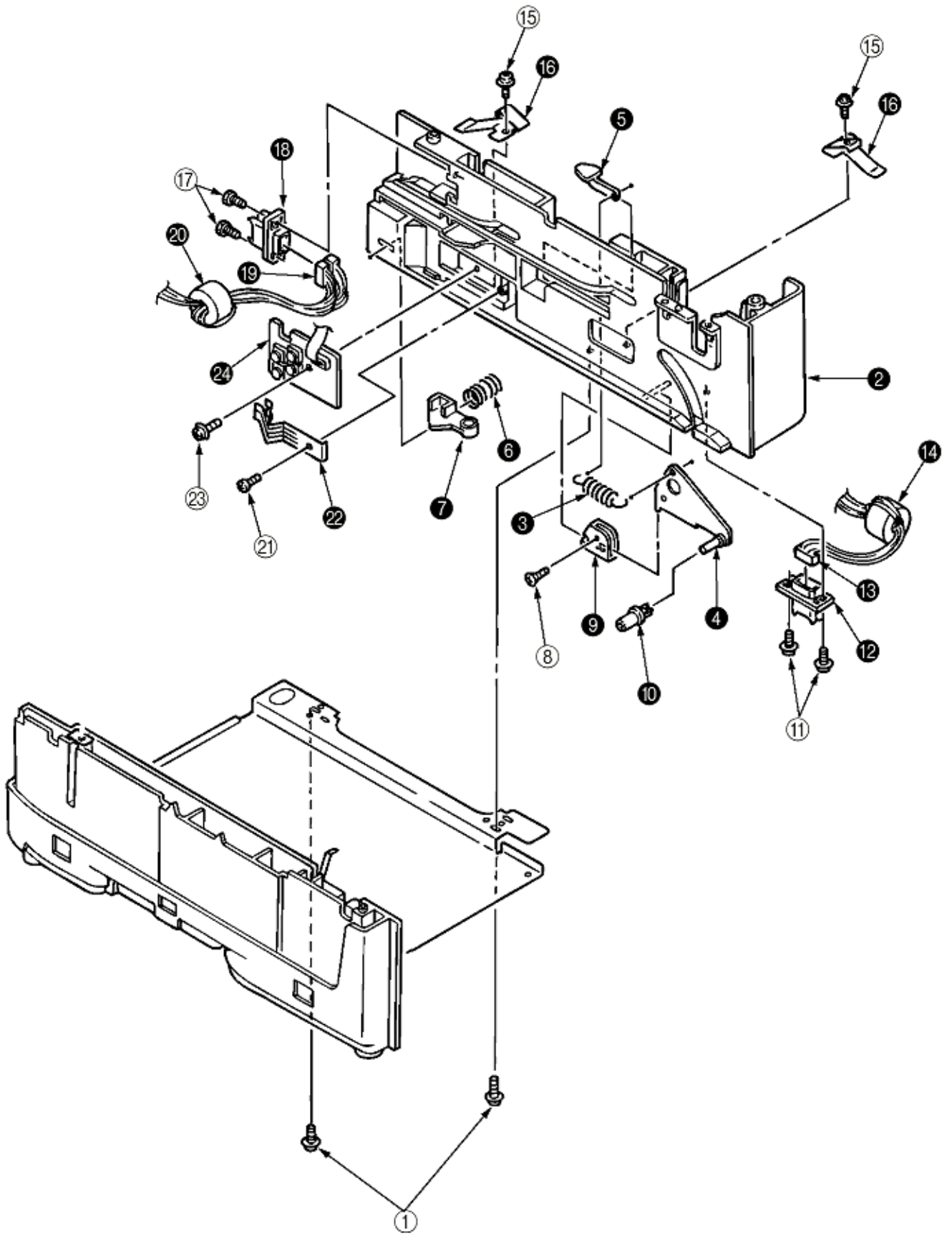

Copyright 1998, Okidata, Division of OKI America, Inc. All rights reserved. See the OKIDATA Business Partner Exchange (BPX) for any updates to this material. (<http://bpx.okidata.com>)



Service Guide OKIPAGE 18/18n Chapter 4 Adjustment

4.0 Adjustment

This chapter explains the adjustment necessary when replacing a part. Adjustment is made by changing a parameter value set in EEPROM on the controller PCB. The parameters are set with key presses from the operator panel. This printer has three maintenance modes used to reset page counts when replacing a part, fine tune, troubleshoot and diagnose.

Copyright 1998, Okidata, Division of OKI America, Inc. All rights reserved. See the OKIDATA Business Partner Exchange (BPX) for any updates to this material. (<http://bpx.okidata.com>)



4.1 Maintenance Modes and Functions

- **User maintenance mode**

To enter the user maintenance mode, turn on the POWER switch while pressing the MENU key.

[Function]

There are 13 functions as follows.

- Menu reset
- Y adjust
- Hex dump
- Duplex Adjust
- Drum counter reset
- Select paper source command parameter
- Resource Save (Second, Third, Front Tray)
- Receive Buffer Size
- Page placement
- Operator panel menu disable
- Setting
- X adjust
- Cleaning cycle

- **System maintenance mode**

Note: This mode is used only by service personnel and should not be released to the end-user. To enter the system maintenance mode, turn on the POWER switch while pressing the RECOVER key.

[Function]

There are 8 functions as follows.

- Page count display
- Page count printing enable/disable
- Rolling ASCII continuous printing
- RS232C LOOP TEST
- EEPROM reset
- HSP ERROR recovery
- HSP ERROR count display
- HSP ERROR count reset
- SIDM enable/disable

- **Engine maintenance mode**

Note: This mode is used only by service personnel and should not be released to the end-user.

To enter the engine maintenance mode, turn on the POWER switch while pressing the FORM FEED key and ENTER key.

[Function]

There are 19 functions as follows.

- Head type setting
- Head drive time setting.
- Head drive time setting at Auto head type
- Head strobe time at 600 x 1200 dpi
- Printing start position setting
- Drum counter total display
- Drum count display
- Setting of standard paper feed length
- Setting of front feeder paper feed length
- Setting of second tray paper feed length
- Selection of second tray feeder download table
- Setting of third tray paper feed length
- Selection of third tray feed download table
- Setting of Multi-purpose feeder paper feed length
- Selection of Multi-purpose feeder download table
- Setting of duplex feed length
- Fuser count indication
- Fuser count reset
- Engine reset

Copyright 1998, Okidata, Division of OKI America, Inc. All rights reserved. See the OKIDATA Business Partner Exchange (BPX) for any updates to this material. (<http://bpx.okidata.com>)



Service Guide OKIPAGE 18/18n

Chapter 4 Adjustment

4.1.1 User maintenance mode

- To enter the user maintenance mode, turn the power supply ON while pressing the Menu key.
- This mode uses the menu for function selection.
- The user maintenance mode provides the following functions:
 - (1) Menu reset
 - All settings for Menu level-1 are reset to the factory default values. The menus for all executable emulations including options are reset to the factory default values.
 - The operation mode starts automatically upon completion of resetting.
 - (2) Hex dump
 - The data received from the host is dumped in hexadecimal notation to the printer.
 - Printing is activated automatically when the received data exceeds one page. If the received data is less than one page, printing can be activated manually by pressing the Form Feed key after selecting the OFF LINE mode by pressing the ON-LINE key. (Automatic activation of printing even when the received data is less than one page by selecting the Auto Eject function on the menu.)
 - To exit from this mode, turn the power OFF.
 - (3) Drum counter reset
 - This function resets the drum life data when the user replaces the image drum unit.
 - The operation mode starts automatically upon completion of resetting.
 - (4) Resource Save
 - Set the storage area size of resource to be stored between PCL and Postscript.
 - (5) Receive Buffer Size
 - Set the receive buffer.
 - (6) Operator panel menu disable
 - This function is for enabling and disabling the operator panel menu functions (Menu 1, Menu 2, Tray Select, Copies and Paper Size).
 - (7) X ADJUST
 - This function is used to adjust the printing start position within the range of ± 2 mm in 0.25 mm steps in the X direction.
 - (8) Y ADJUST
 - This function is capable to adjust the printing start position within the range of ± 2 mm in 0.25 mm steps in the Y direction.

(9) Duplex adjust

- The function which performs a correction in Y direction towards the sheet supplied from the tray in double-sided printing.

(10) Select paper source command parameter (Second tray)

- The function which sets the parameter selecting the second tray by paper source command (ESC & N # H) on PCL. (11) Select paper source command parameter (Third tray)
- The function which sets the parameter selecting the third tray by paper source command (ESC & N # H) on PCL.

(11) Select paper source command parameter (Third tray)

- The function which sets the parameter selecting the third tray by paper source command (ESC & I # H) on PCL.

(12) Select paper source command parameter (Front tray)

- The function which sets the parameter selecting the front tray by paper source command (ESC & N # H) on PCL.

(13) Page placement

- The function which aligns a printing image to the right.

(14) SETTING

- This function is used to adjust to improve print quality.

-2 } Rough/thick paper, Low temperature/humidity and/or blotchy faded print appeared.

-1 } Rough/thick paper, Low temperature/humidity and/or blotchy faded print appeared.

0 } Normal media/environmental conditions.

+1 } Rough papers, high temperature/humidity and/or snowy print of high density pattern.

+2 } Rough papers, high temperature/humidity and/or snowy print of high density pattern.

(15) Cleaning cycle

- Set the page interval to perform Cleaning Sequence.

When stains build up especially in using rough papers. Change the cleaning cycle. The shorter the cycle is set, the less the stains become.

Normal : Each 20th page (default)

Middle : Each 10th page

High : Each 3rd page

User maintenance mode menu system

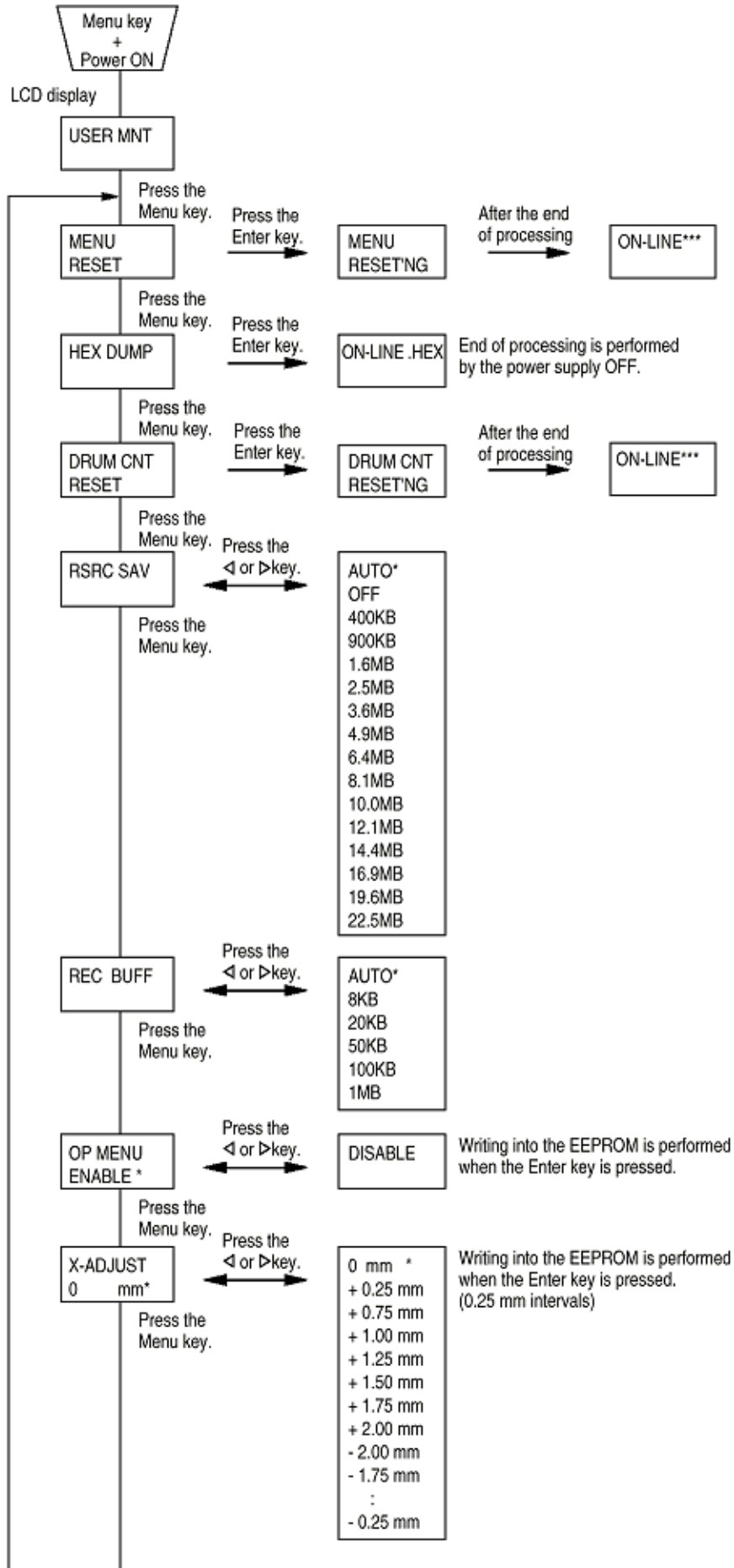

Menu key + Power ON

LCD display

USER MNT

Press the Menu key.

MENU RESET

Press the Enter key.

MENU RESE'T'NG

After the end of processing

ON-LINE***

Press the Menu key.

HEX DUMP

Press the Enter key.

ON-LINE .HEX

End of processing is performed by the power supply OFF.

Press the Menu key.

DRUM CNT RESET

Press the Enter key.

DRUM CNT RESE'T'NG

After the end of processing

ON-LINE***

Press the Menu key.

RSRC SAV

Press the < or > key.

AUTO* OFF
400KB
900KB
1.6MB
2.5MB
3.6MB
4.9MB
6.4MB
8.1MB
10.0MB
12.1MB
14.4MB
16.9MB
19.6MB
22.5MB

Press the Menu key.

REC BUFF

Press the < or > key.

AUTO* 8KB
20KB
50KB
100KB
1MB

Press the Menu key.

OP MENU ENABLE *

Press the < or > key.

DISABLE

Writing into the EEPROM is performed when the Enter key is pressed.

Press the Menu key.

X-ADJUST

Press the < or > key.

0 mm *
+ 0.25 mm
+ 0.75 mm
+ 1.00 mm
+ 1.25 mm
+ 1.50 mm
+ 1.75 mm
+ 2.00 mm
- 2.00 mm
- 1.75 mm
:
- 0.25 mm

Writing into the EEPROM is performed when the Enter key is pressed. (0.25 mm intervals)

Press the Menu key.

Copyright 1998, Okidata, Division of OKI America, Inc. All rights reserved. See the OKIDATA Business Partner Exchange (BPX) for any updates to this material. (<http://bpx.okidata.com>)

4.1.2 System maintenance mode

- The system maintenance mode is set when the power is turned ON while pressing the Recover key.
- This mode adopts the menu for function selection.
- The system maintenance mode is provided with the following functions:
 - (1) Page count display
 - The total number of pages counted at the engine is displayed on the LCD.
 - (2) Page count printing enable/disable
 - This function selects whether to include (enable) or exclude (disable) the total number of printed pages counted at the engine at the time of menu printing.
 - (3) Rolling ASCII continuous printing
 - The rolling ASCII pattern is printed continuously for various engine tests.
 - Press the ON-LINE key to cancel this mode.
 - (4) RS232C LOOP TEST
 - Performs a loop test of RS 232C.
 - (5) EEPROM reset
 - All EEPROM areas including Menu level-2 to the factory default values.
 - The following items are excluded
 - * Head drive time setting
 - * Fine adjustment of printing start position
 - * Standard tray paper feed amount setting
 - Transition to the operation mode occurs upon completion of resetting.
 - Press the Menu key to update each category. The operation returns to the first category after updating the last category.
 - (6) HSP ERROR recovery
 - Select HSP ERROR recovery function either recover or stop.
 - (7) HSP ERROR count
 - Display total HSP ERROR count.
 - (8) HSP ERROR count reset

- Reset the HSP ERROR counter.

(9) SIDM enable/disable

- If it's selected disable, cannot select SIDM emulations by Menu.

System maintenance mode menu system

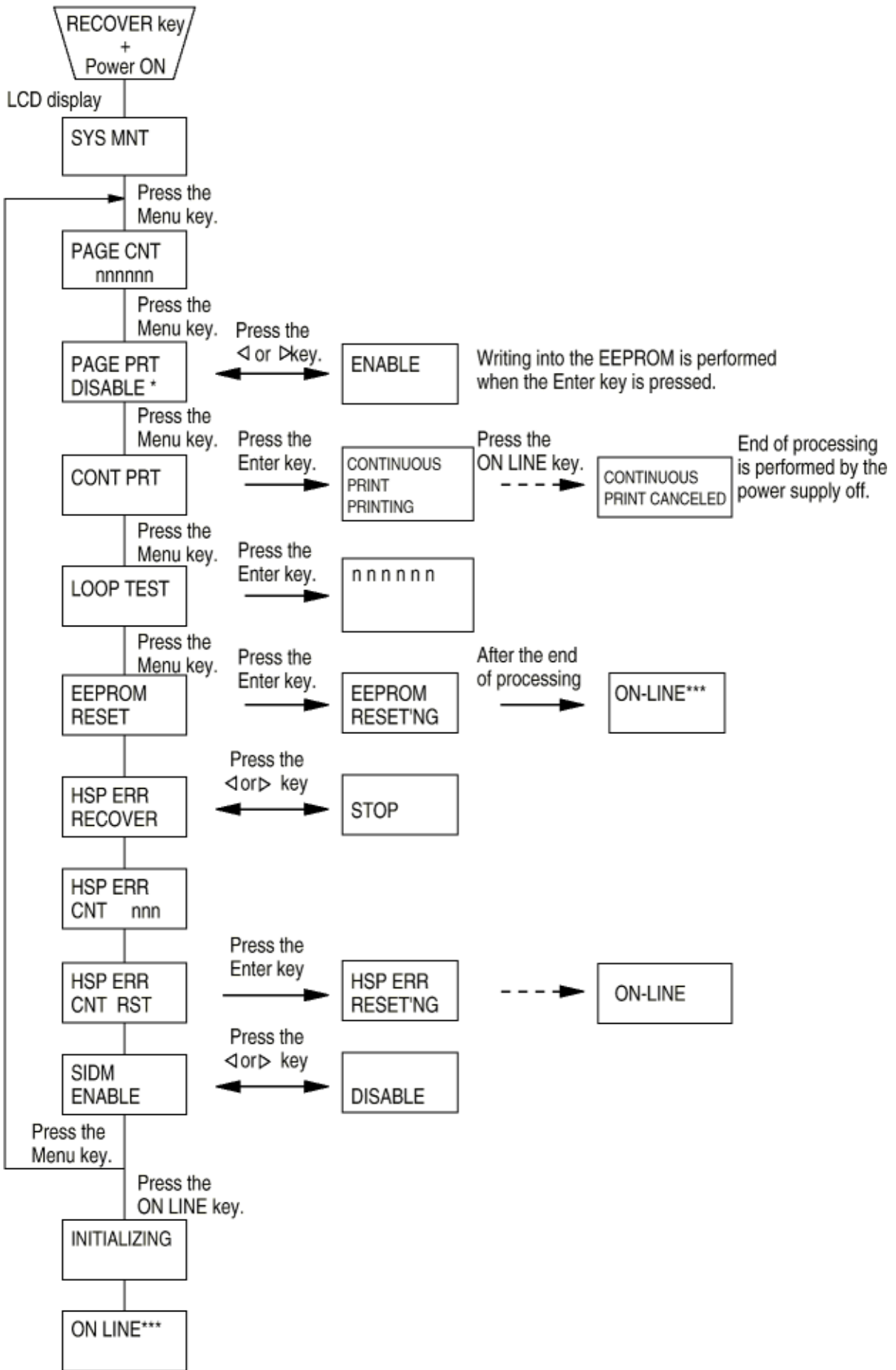

Copyright 1998, Okidata, Division of OKI America, Inc. All rights reserved. See the OKIDATA Business Partner Exchange (BPX) for any updates to this material. (<http://bpx.okidata.com>)

4.1.3 Engine maintenance mode

- The engine maintenance mode is activated when the power is turned ON while pressing the Form Feed key and Enter key.
- This mode adopts the menu for function selection.
- The method for exit from this mode depends on the setting.
- The engine maintenance mode is provided with the following functions:
 - (1) Head type setting select LED Head type
 - Sets the select LED head type.
 - (2) Head drive time setting
 - Sets the drive time of the LED head.
 - (3) Head drive time setting at auto head type
 - This function sets head drive time, when " HEADTYPE= AUTO" is selected.
 - (4) Head strobe time at 600 x 1200 dpi
 - This function sets head strobe time at 600 x 1200 dpi.
 - (5) Printing start position setting
 - Sets the printing start position.
 - (6) Drum count total display
 - Displays on the LCD the total number of drum revolutions in the unit counted at the engine.
 - (7) Drum count display
 - Displays on the LCD the total number of EP drum revolutions counted at the engine.
 - (8) Setting of standard tray paper feed length
 - This function sets the paper feed length of standard tray paper.
 - (9) Setting of front feeder paper feed length
 - This function sets the paper feed length of the front feeder.
 - (10) Setting of High Capacity Second Paper Feeder paper feed length
 - This function sets the paper feed length of the High Capacity Second Paper Feeder.
 - (11) Selection of High Capacity Second Paper Feeder download table
 - This function selects the download table for the High Capacity Second Paper Feeder.

(12) Setting of High Capacity Third Paper Feeder paper feed length

- This function sets the paper feed length of the High capacity Third paper feeder.

(13) Selection of High Capacity Third paper feeder download table

- This function selects the download table for the High capacity third paper feeder.

(14) Setting of Multi Feeder paper feed length

- This function sets the paper feed length of the Multi Feeder.

(15) Selection of Multi Feeder download table

- This function selects the download table for the Multi Feeder.

(16) Setting of duplex feed length

- This function sets the paper feed length of the duplex.

(17) Fuser count display

- Displays on the LCD the total number of printed pages counted at the engine.

(18) Fuser count reset

- When the fuser unit is replaced, the maintenance person uses this fuser count reset function to reset the fuser lifetime.
- After the fuser counter is reset, the engine enters into the operation mode automatically

(19) Engine reset

- All EEPROM areas used by the engine are reset to the factory default values.
- The following items are excluded:
 - * Menu level-1
 - * Menu level-2
 - * Operator panel menu disable/enable
 - * Page print disable/enable
- Transition to the operation mode occurs upon completion of resetting.

Note: Do not change the default value of (1)~ (5), (8)~ (16) they are the parameter for adjusting in the factory.

- **Engine maintenance mode menu system**

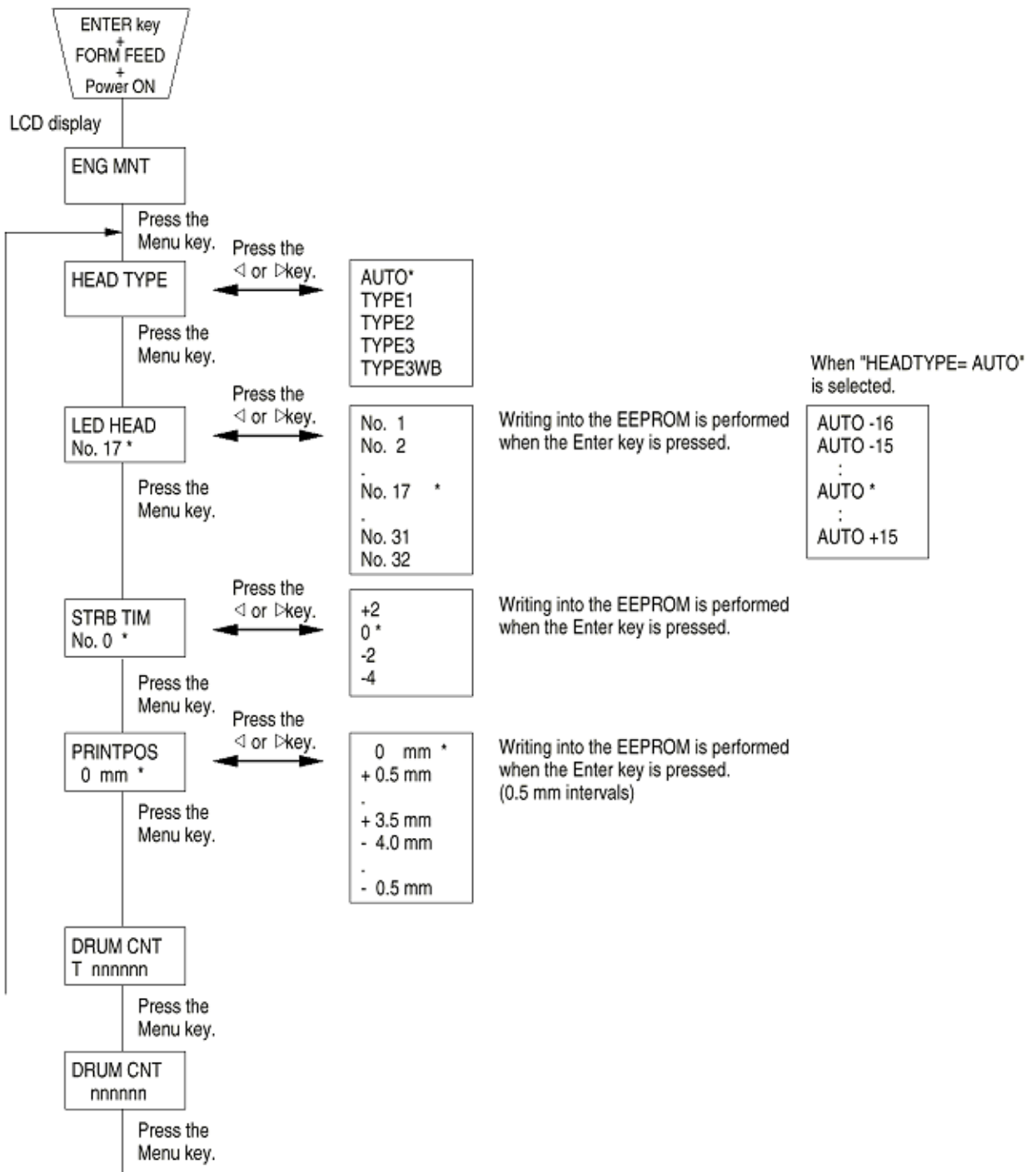

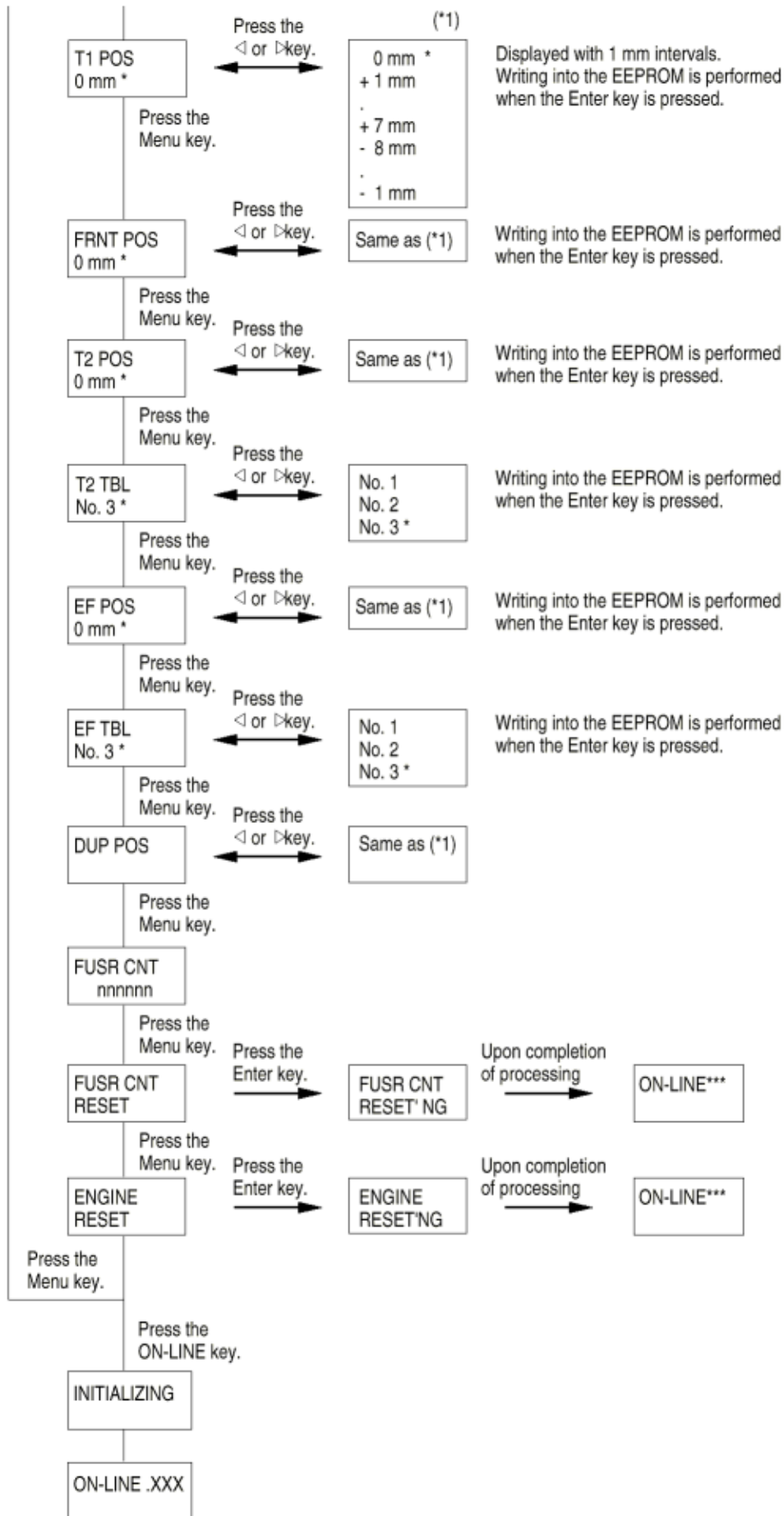

Copyright 1998, Okidata, Division of OKI America, Inc. All rights reserved. See the OKIDATA Business Partner Exchange (BPX) for any updates to this material. (<http://bpx.okidata.com>)

Service Guide OKIPAGE 18/18n
Chapter 4 Adjustment

4.1.4 EEPROM initialization

The corresponding area of the EEPROM is initialized for each event as shown Table 4-1 and Table 4-2.

Table 4-1 EEPROM Initial Setting Range

No	Event	Menu Level 1	Menu level 2	F/W Revision Range	Destination Information	Users Maintenance Range (note1)	Systems Maintenance Range (note1)	Engine Maintenance Range (note1)	Drum Counter	Fuser Counter	Total Print Number	HSP
1	Users Maintenance Menu Reset	<input type="radio"/>										
2	Systems Maintenance EEPROM Reset	<input type="radio"/>	<input type="radio"/>			<input type="radio"/>	<input type="radio"/>					
3	Engine Maintenance Engine Reset							<input type="radio"/>	<input type="radio"/>			
4	Firm Revision Check Error Power On	<input type="radio"/>	<input type="radio"/>	<input type="radio"/>		<input type="radio"/>	<input type="radio"/>					
5	Engine ID Check Error at Power On							<input type="radio"/>	<input type="radio"/>	<input type="radio"/>	<input type="radio"/>	<input type="radio"/>
6	Setting for Shipping Destination	<input type="radio"/>	<input type="radio"/>		<input type="radio"/>	<input type="radio"/>	<input type="radio"/>					
7	Users Information Error	<input type="radio"/>	<input type="radio"/>		<input type="radio"/>	<input type="radio"/>	<input type="radio"/>					

Note 1 : The items for each maintenance menu of the events are to be listed.

Table 4-2 Items Related to Each Maintenance Menu of EEPROM Reset

Users Maintenance Menu Range	Systems Maintenance Menu Range	Engine Maintenance Menu Range
Resource Save	Enable/ Disable of Total Number of Menu Print	Correction head type (excluding the time upon engine maintenance engine reset)
Receive Buffer	Enable/ Disable of Switching SIDM Emulation	LED head drive time (excluding the time upon engine maintenance engine reset)
Enable/ Disable of Operator Panel Menu Function		600 x 1200dpi strobe time relative value (excluding the time upon engine maintenance engine reset)
X/ Y/ DUP ADJUST		Print start position
Paper Feed Command of 2nd/ 3rd/ Front Trays		Paper feed distance from each tray
Print Shift to Left Based		Paper feed distance from the Duplex Unit
Cleaning Cycle		Control parameter of each option tray motor
		Engine test



Service Guide OKIPAGE 18/18n

Chapter 4 Adjustment

4.2 Adjustment When Replacing a Part

Adjustment necessary when replacing one of the following parts.

Parts to be Replaced	Adjustment
Image Drum Unit	Reset the drum counter. (Refer to User's Manual)
Fuser Unit	Reset the fuser counter. (Refer to Chapter 4.2.1)

4.2.1 Setting LED Head Drive Time

4.2.2 Destination Setting

4.2.3 Setting of ED had drive time

4.2.1 Setting LED Head Drive Time

(1) The fuser counter can be reset in the engine maintenance mode.

(2) Resetting method

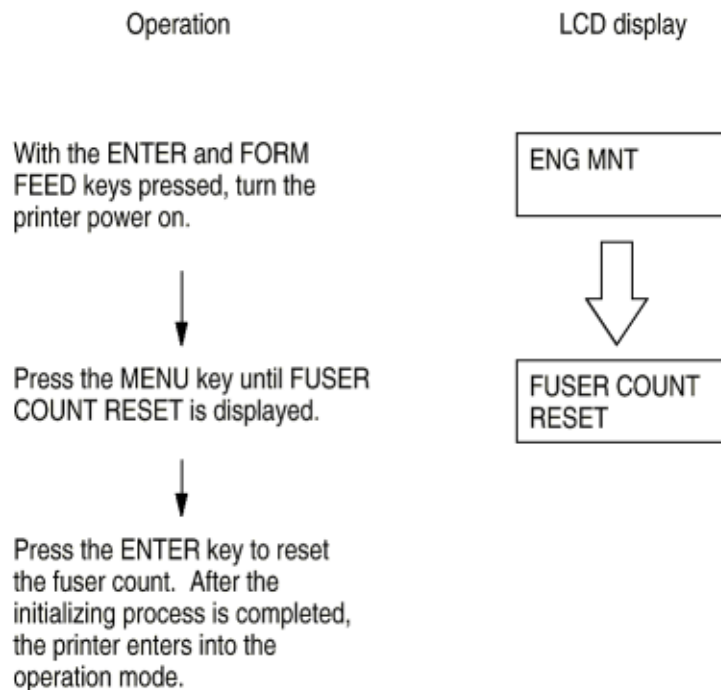



4.2.2 Destination setting

The desired destination can be set by turning the power on while depressing two keys corresponding to the destination according to the following table.

Destination	Keys to be depressed
ODA	MENU, ▷

This function shall not be open for users.

Copyright 1998, Okidata, Division of OKI America, Inc. All rights reserved. See the OKIDATA Business Partner Exchange (BPX) for any updates to this material. (<http://bpx.okidata.com>)

4.2.3 Setting of LED head drive time

As the OKIPAGE18/18n automatically judges head type and head drive time, there is no need for changing any setting in replacing LED head. But individual setting can be changed by ENGINE Maintenance menu as before. The procedure in such case shown below.

- Luminous intensity marking label

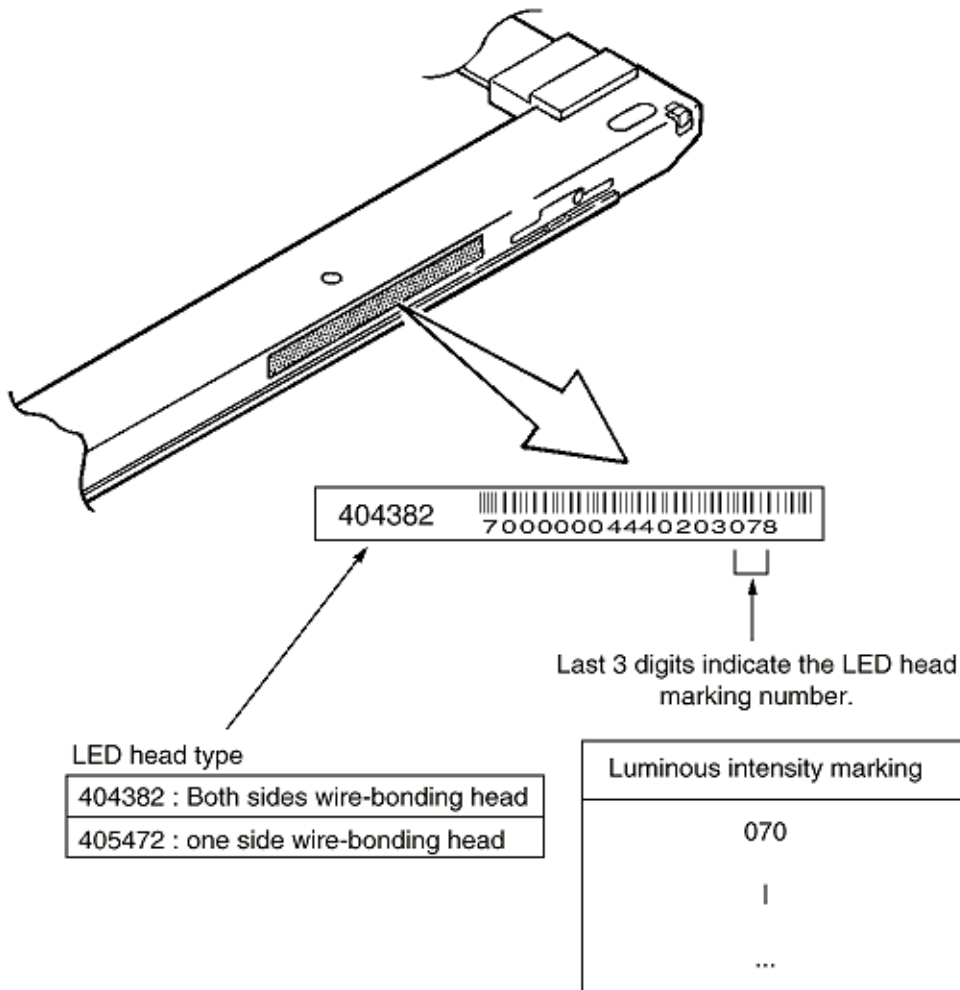

- Setting of LED head drive time

Drive time of the LED head is to set parameter of drive time setting values corresponding to the luminous intensity displays marked on the LED head to EEPROM.

- Corresponding table of luminous energy display and drive time parameter

Luminous intensity display on LED head	Drive time parameter	Luminous intensity display on LED head	Drive time parameter
0.27 ~ 0.28	25	0.61 ~ 0.64	13
0.29 ~ 0.30	24	0.65 ~ 0.69	12
0.31 ~ 0.32	23	0.70 ~ 0.73	11
0.33 ~ 0.35	22	0.74 ~ 0.79	10
0.36 ~ 0.37	21	0.80 ~ 0.84	9
0.38 ~ 0.40	20	0.85 ~ 0.90	8
0.41 ~ 0.43	19	0.91 ~ 0.96	7
0.44 ~ 0.46	18	0.97 ~ 1.03	6
0.47 ~ 0.49	17	1.04 ~ 1.10	5
0.50 ~ 0.52	16	1.11 ~ 1.18	4
0.53 ~ 0.57	15	1.19 ~ 1.26	3
0.58 ~ 0.60	14	1.27 ~ 1.35	2

b. Setting

Example : When setting head type to TYPE3WB(both-sided wire-bonding head) and head drive time to No. 14.

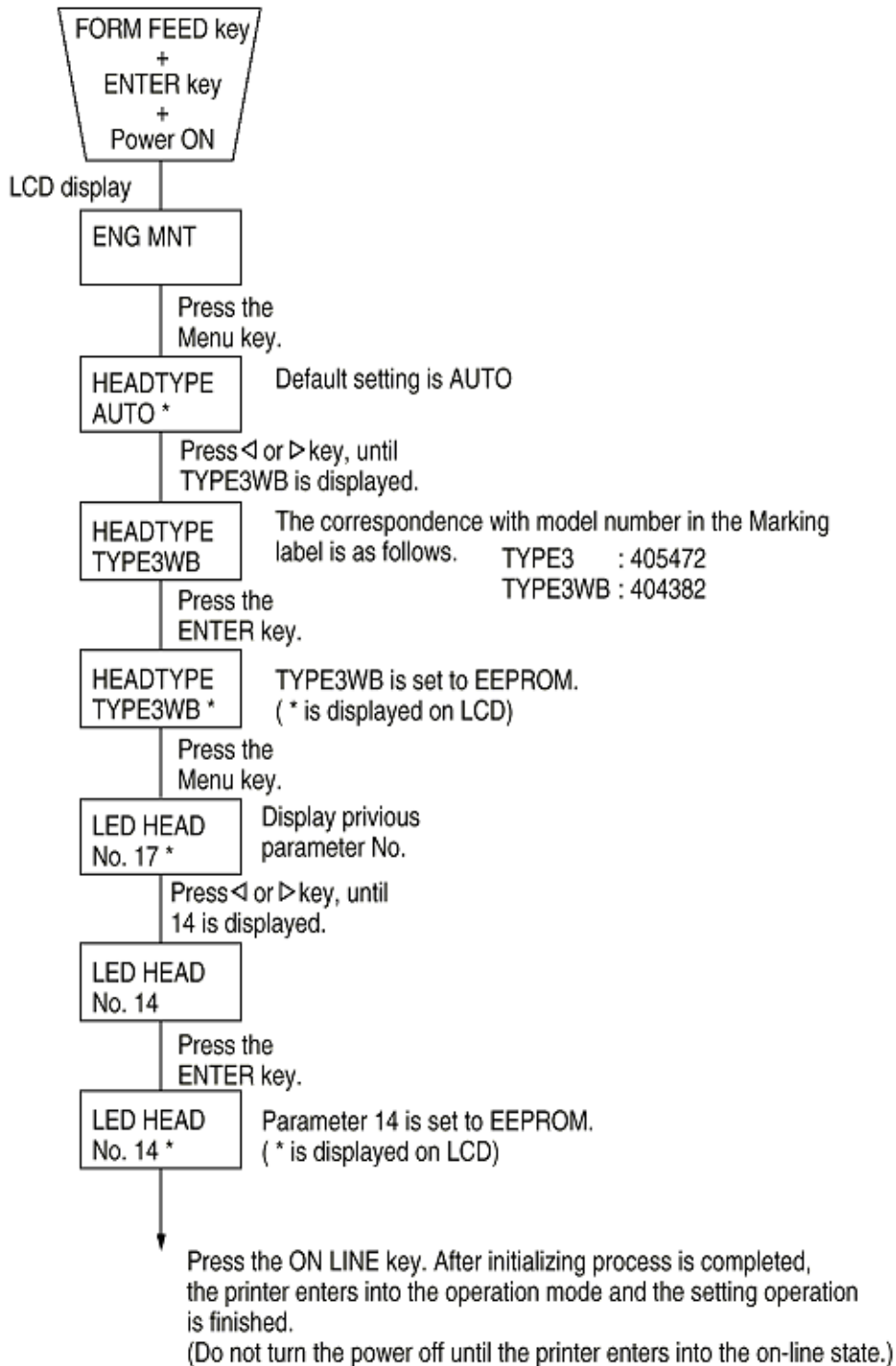



Service Guide OKIPAGE 18/18n

Chapter 5 Periodical Maintenance

5.1 Periodic Maintenance

Table 5-1 lists the part and unit to be replaced periodically.

Table 5-1 Routine Replacement Parts

Part Name	Condition for replacement	Cleaning	Remarks
Toner cartridge	5,000	<ul style="list-style-type: none">● LED head.● Regist. Paper dust.	Consumables
Image drum unit	30,000	<ul style="list-style-type: none">● LED head.● Regist. Paper dust.	Consumables
Heat Assy	200,000		Maintenance Kit
Transfer Roller	200,000		Maintenance Kit
Back up Roller Assy	200,000		Maintenance Kit
Feed Roller Assy	200,000		Maintenance Kit
Hopping Roller Assy	200,000		Maintenance Kit
Separation Frame Assy	200,000		Maintenance Kit

[**Note:** Maintenance Kit shall be replenished by users calling to serviceman.]

Copyright 1998, Okidata, Division of OKI America, Inc. All rights reserved. See the OKIDATA Business Partner Exchange (BPX) for any updates to this material. (<http://bpx.okidata.com>)



Service Guide OKIPAGE 18/18n

Chapter 5 Periodical Maintenance

5.2 Cleaning

Remove any toner or dust. Clean inside and around the printer with a piece of cloth when necessary. Use the handy cleaner (VACUUM) for cleaning the printers interior.

Note: Do not touch the image drum unit, LED lens array or LED head connector block.

5.2.1 Cleaning the LED Lens Array

Copyright 1998, Okidata, Division of OKI America, Inc. All rights reserved. See the OKIDATA Business Partner Exchange (BPX) for any updates to this material. (<http://bpx.okidata.com>)

5.2.1 Cleaning the LED Lens Array

Clean the LED lens array or replace the toner cartridge when white lines or stripes (void, light printing) are generated vertically down the page.

Note: The LED lens array must be cleaned with an LED head cleaner.

White lines or stripes
(void, light printing)



(1) Set the LED head cleaner in the LED lens array, as shown in the figure below, and slide the cleaner left and right several times to clean the head.

Caution: Do not press the LED head cleaner against the LED lens array.

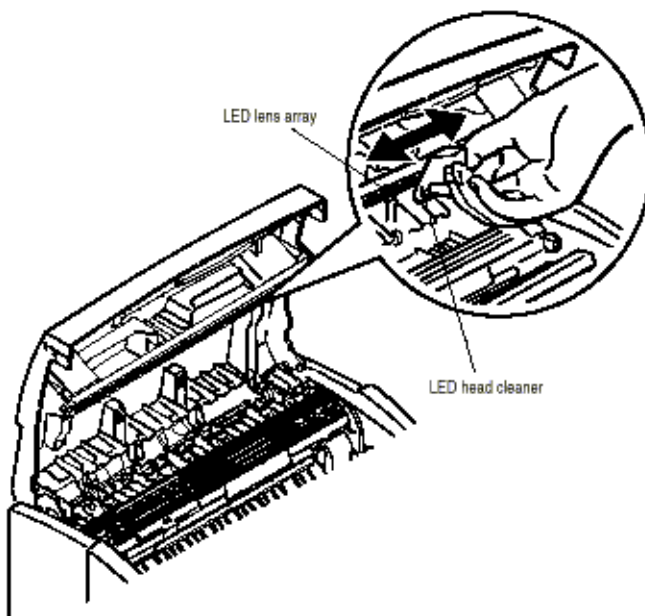
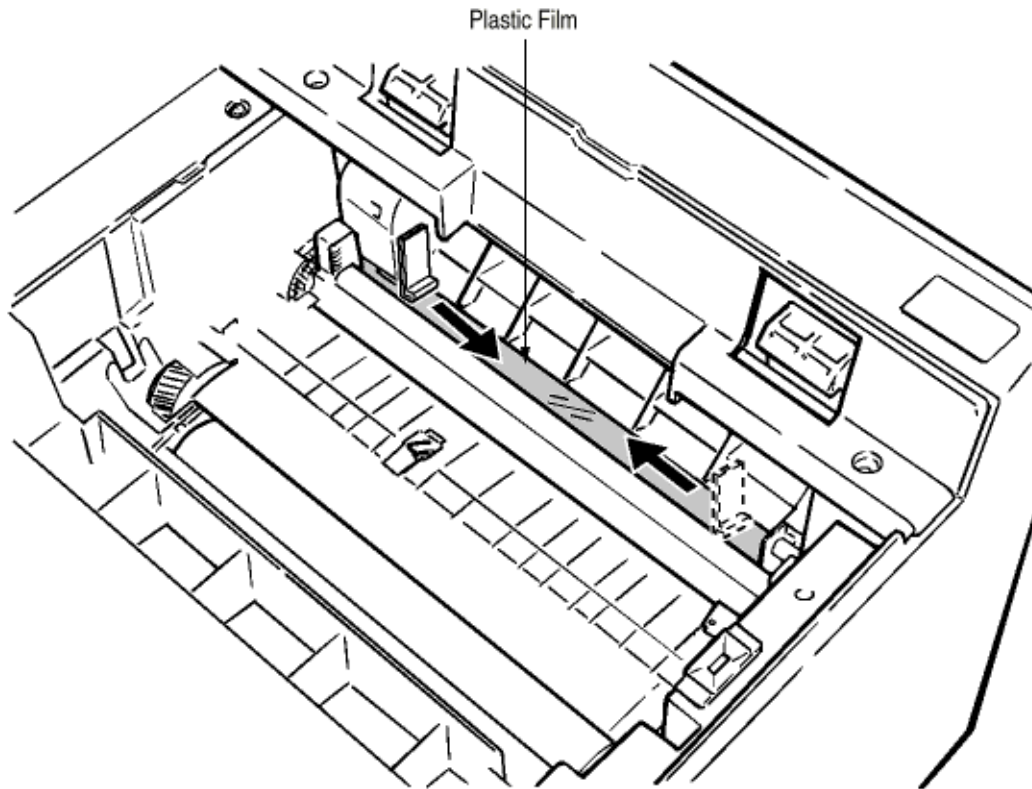

Figure 5-2

Copyright 1998, Okidata, Division of OKI America, Inc. All rights reserved. See the OKIDATA Business Partner Exchange (BPX) for any updates to this material. (<http://bpx.okidata.com>)

5.2.2 Cleaning the Plastic Film

- (1) Open the stacker assy and remove I/D unit.
- (2) After cleaning LED head, wipe off the paper powder by LED LENS CLEANER and remove the paper powder.



- (3) Remove paper powder out of the printer unit in such a way as not to spill it and dispose of properly

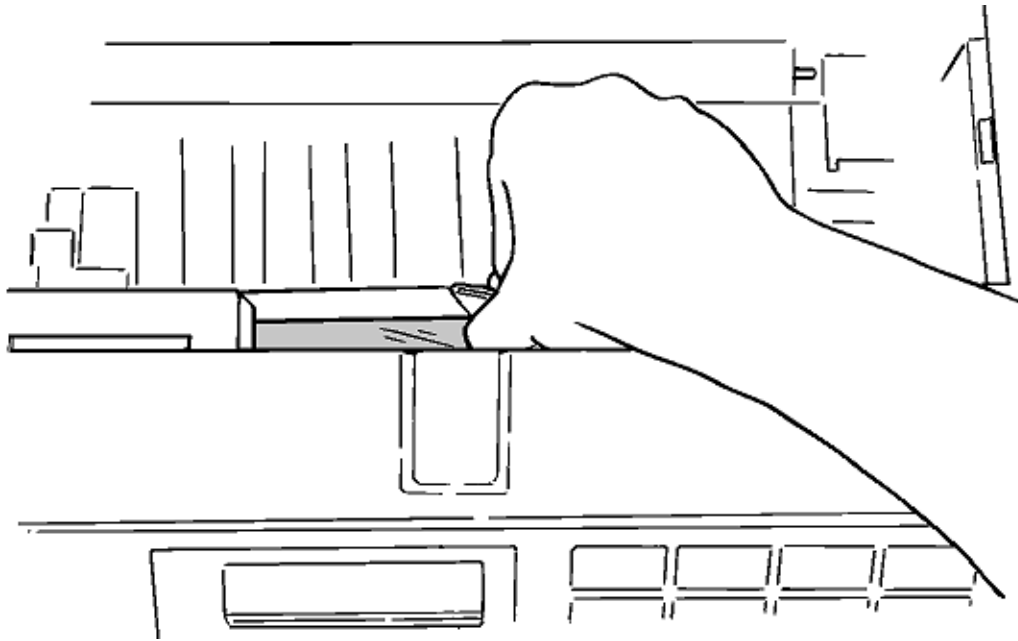

Copyright 1998, Okidata, Division of OKI America, Inc. All rights reserved. See the OKIDATA Business Partner Exchange (BPX) for any updates to this material. (<http://bpx.okidata.com>)



6.1 Troubleshooting Tips

1. Check the basic check points written in the user's manual.
2. Gather as much information on the problem from the customer as possible.
3. Perform inspections in conditions close to those in which the problem had occurred.

Copyright 1998, Okidata, Division of OKI America, Inc. All rights reserved. See the OKIDATA Business Partner Exchange (BPX) for any updates to this material. (<http://bpx.okidata.com>)



Service Guide OKIPAGE 18/18n Chapter 6 Troubleshooting Procedures

6.2 Check Points Before Correcting Image Problems

1. Is the printer being run in proper ambient conditions?
 2. Have the supplies (toner) and the routine replacement part (image drum cartridge) been replaced properly?
 3. Is the paper normal? See paper specifications section.
 4. Has the image drum cartridge been loaded properly?
-

Copyright 1998, Okidata, Division of OKI America, Inc. All rights reserved. See the OKIDATA Business Partner Exchange (BPX) for any updates to this material. (<http://bpx.okidata.com>)



Service Guide OKIPAGE 18/18n Chapter 6 Troubleshooting Procedures

6.3 Notes When Correcting Image Problems

1. Do not touch, or bring foreign matter into contact with the surface of the image drum.
 2. Do not expose the image drum to direct sunlight.
 3. Keep hands off the fuser unit as it is heated during operation.
 4. Do not expose the image drum to light for longer than 5 minutes at room temperature.
-

Copyright 1998, Okidata, Division of OKI America, Inc. All rights reserved. See the OKIDATA Business Partner Exchange (BPX) for any updates to this material. (<http://bpx.okidata.com>)



Service Guide OKIPAGE 18/18n Chapter 6 Troubleshooting Procedures

6.4 Preparation Before Troubleshooting

(1) Operator panel display

The failure status of this printer is displayed on the liquid crystal display (LCD) in the operator panel. Take proper corrective action as directed by messages that are displayed on the LCD.

Copyright 1998, Okidata, Division of OKI America, Inc. All rights reserved. See the OKIDATA Business Partner Exchange (BPX) for any updates to this material. (<http://bpx.okidata.com>)

6.5 Troubleshooting Flowchart

If troubles should develop in this printer, troubleshoot in the following procedure flow:

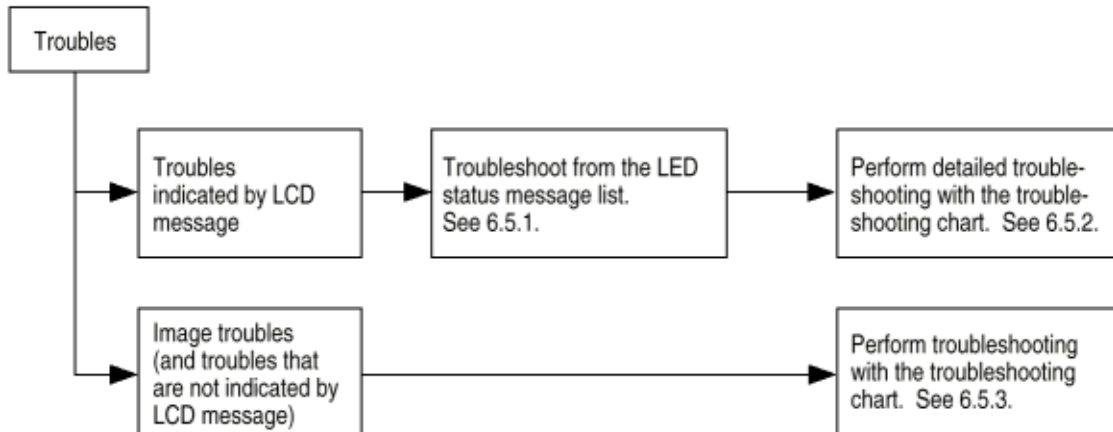
**6.5.1 LCD status message/trouble list****6.5.2 LCD message troubleshooting****6.5.3 Image troubleshooting**

6.5.1 Status Monitor Message List

Table 6-1 lists the statuses and troubles to be displayed on the status monitor in the message format.

LED status

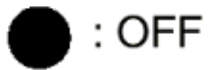

Table 6-1

Category	Status Message	Status Code	Explanation	Remedy
Normal status	Warming Up	18 00	Warming-up status.	Normal operation.
Normal status	Online (Ready)	00 10	Online (ready) status.	Normal operation.
Normal status	Power Save Mode	00 20	Power save status.	Normal operation.
Normal status	Toner Low	10 00	The toner amount of the toner cartridge is small.	Normal operation/replace the toner cartridge.
Normal status	Toner Sensor	10 01	The image drum is not installed or the toner sensor is faulty.	Install the image drum or replace the toner sensor.
Normal status	Change Drum	10 02	Image drum is nearing end of life.	Replace the image drum. Note: Be sure to reset the drum counter after replacing the image drum).
Normal status	Manual Paper In	12 20	The paper is in the manual feed mode.	Normal operation.
Normal status	Printing In Progress	14 20	Printing in progress.	Normal operation.
Normal status	Ejection in Progress	14 30	Ejection in progress.	Normal operation.

Normal status	Manual Request Executive Letter Legal 14 Legal 13 A6 A5 A4 B5 Monarch COM-10 DL C5 COM-9	16 01 16 02 16 03 16 04 16 18 16 19 16 1A 16 21 16 50 16 51 16 5A 16 5B 16 7F	Request the paper to be set in the manual feed mode. The paper sizes are as follows: Executive, Letter, Legal 14, Legal 13, A4, A5, A6, B5, Monarch, DL, C5, COM-10, COM-9.	Set the requested paper in the manual feed mode.
Paper size error	Paper Size Error	30 00	Paper of improper size was fed. 2.52" (64 mm) L 15.77" (400.56 mm)	Check the paper. Also check whether more than one sheet of paper were fed simultaneously. To clear the error display, open the cover, then close it.
Paper jam	Paper Input Jam	31 00	A paper jam occurred when sheets of paper were being supplied.	Check the paper. To release the error display, open the cover, then close it.
Paper jam	Paper Feed Jam	32 00	A paper jam occurred during paper feeding.	Open the cover, then remove the jammed paper. To clear the error display, close the cover.
Paper Jam	Paper Exit Jam	33 00	A paper jam occurred during paper ejection.	Open the cover, then remove the jammed paper. To clear the error display, close the cover. If this error occurs frequently, see Section 6.5.2.
Cover Open	Cover Open	4F 00	The upper cover is open.	To clear the error display, close the cover. If this error occurs frequently, replaced the power supply board.
Buffer overflow	Page Buffer Overflow	40 01	The page buffer overflowed because there are a large number of print data.	To release the error display, press the reset button on the status monitor of the printer driver. Install option RAM or reduce the number of print data.

Buffer overflow	Print Over Run	40 10	A print overrun occurred because print data is complicated.	To clear the error display, press the reset button on the status monitor of the printer driver. Simplify the print data format.
Device configuration error	Program ROM Check Error	60 10	An error occurred during program ROM check.	Replace program ROM or the main control board. (When replacing the main control board, also adjust EEPROM data).
Device configuration error	Resident RAM Check Error	60 30	An error occurred during resident RAM check.	Replace the main control board. (When replacing the main control board, also adjust EEPROM data).
Device configuration error	EEPROM Check Error	60 40	An error occurred during EEPROM check.	Replace the main control board. (When replacing the main control board, also adjust EEPROM data).
Device configuration error	Option RAM Check Error	60 60	An error occurred during option RAM check.	Check the connection of the Option RAM PC board. If the option RAM PC board is faulty, replace it.
Device configuration error	Fuser Error	60 80	A heater timeout error occurred.	see Section 6.5.2.
Device configuration error	Thermistor Error	60 90	A thermistor error occurred.	Replace the thermistor of the heater Assy.
Device configuration error	Thermistor Open Check Error	60 91	The thermistor is open.	Replace the thermistor of the heater Assy.
Device configuration error	Thermistor Short Check Error	60 92	A thermistor short occurred.	Replace the thermistor of the heater Assy.
Device configuration error	Watch Dog Timeout Error	60 00	A watchdog timeout occurred.	To clear the error display, turn on the power supply again. Replace the main control board.

Category	LCD status message	Trouble or status	Remedy
----------	--------------------	-------------------	--------

50	An error was detected by optional software ROM.	- Replace the PostScript module (BOARD-MSM or BOARD-FSL).
60	An error was detected by optional RAM check.	- Check the optional RAM for proper connection. - Replace the optional RAM.
70	A fault occurred in the fan motor.	- Connect the fan motor cable properly. - Replace the fan motor. - Power Supply Unit (AC120V/ 230V)
71	A fault occurred in the fuser.	see Section 6.5.2.
72	Thermistor open error.	
73	Thermistor short error.	
74	SSIO error.	
77	Toner sensor error.	Check the operation of the toner sensor lever. Replace the Power Supply Unit (High Voltage). Replace the Main Board. Note: When replacing the main board, install the EEPROM mounted on the replaced main board.
80	I/F timeout occurred between the printer main unit and the operator panel.	see Section 6.5.2.
81	I/F timeout occurred between the printer main unit and the operator panel.	
83	I/F timeout occurred between the printer and the Duplex Unit.	
84	Printing sequence error in the Duplex unit.	
90	A watchdog timer timeout occurred.	- Turn the power off, then on. - Replace the Main board (*BOARD-FFF). Note: When replacing the Main Board, install the EEPROM mounted on the replaced Main Board.
F0	Monitor error (double weight)	see #90 above
F1	Monitor error (argument error)	see #90 above
F2	Optional timeout error	see #90 above
F3	Optional status error	see #90 above
F4	BG program error	see #90 above
F5	System timer program error	see #90 above
F6	IPT2 program error	see #90 above
F7	IPT1 program error	see #90 above

Category: Processor error

LCD message: ERROR CONTROLLER nn-aaaaaaa

READY LED: Light off

ATTENTION LED: Flash

	Trouble or status	Remedy
	An error occurred in the controller. n = (*1) Exception Code aaaaaaaa = Error address	
1*:		
Exception code	Error	
1-3 D-F	Reserved	- Turn the power off, then on. - Replace the Main board. BOARD-FFF) Note: When replacing the Main Board, install the EEPROM mounted on the replaced Main board.
4	Address Error Exception	see above
5	Address Error Exception (Store instruction)	see above
6	Bus Error Exception (Instruction Fetch)	see above
7	Bus Error Exception (Load instruction, store instruction)	see above
8	System Call Exception	see above
9	Breakpoint Exception	see above
A	Reserved Instruction Exception	see above
B	Co-processor Unusable Exception	see above
C	Arithmetic Overflow Exception	see above



Service Guide OKIPAGE 18/18n

Chapter 6 Troubleshooting Procedures

6.5.2 LCD message troubleshooting

If troubles are not correctable from the LCD message trouble list, follow the troubleshooting flowcharts given here to deal with them.

No.	Problem	Flowchart number
1	The printer does not work normally after being turned on.	(1)
2	Jam error	(2)
	<ul style="list-style-type: none">● Paper input jam (1st tray)● Paper input jam (Front feeder)● Paper feed jam● Paper exit jam	(2) - 1 (2) - 2 (2) - 3 (2) - 4
3	Paper size error	(3)
4	Fusing unit error (ERROR71, ERROR72, ERROR73)	(4)
5	SSIO (Synchronous Serial I/O) error (between the Main board and the Power Supply Unit (High Voltage) (ERROR74)	(11)
6	I/F time-out between the printer and the operator panel (ERROR80)	(7)
7	I/F time-out (no response) between the printer and an optional tray (2nd tray, 3rd tray), multi-feeder) (ERROR81)	(5)
8	Messages can not be received through the parallel interface.	(8)
9	Messages can not be received through the serial interface.	(9)
10	Data can not be received through the OKI HSP interface.	(10)
11	I/F time-out between the printer and the Duplex unit. Printing sequence error in the Duplex. (ERROR83, ERROR84)	(6)

Note: When replacing the Main board, install the EEPROM from the old Main board, onto the new Main board.



(1) The printer does not work normally after being turned on.

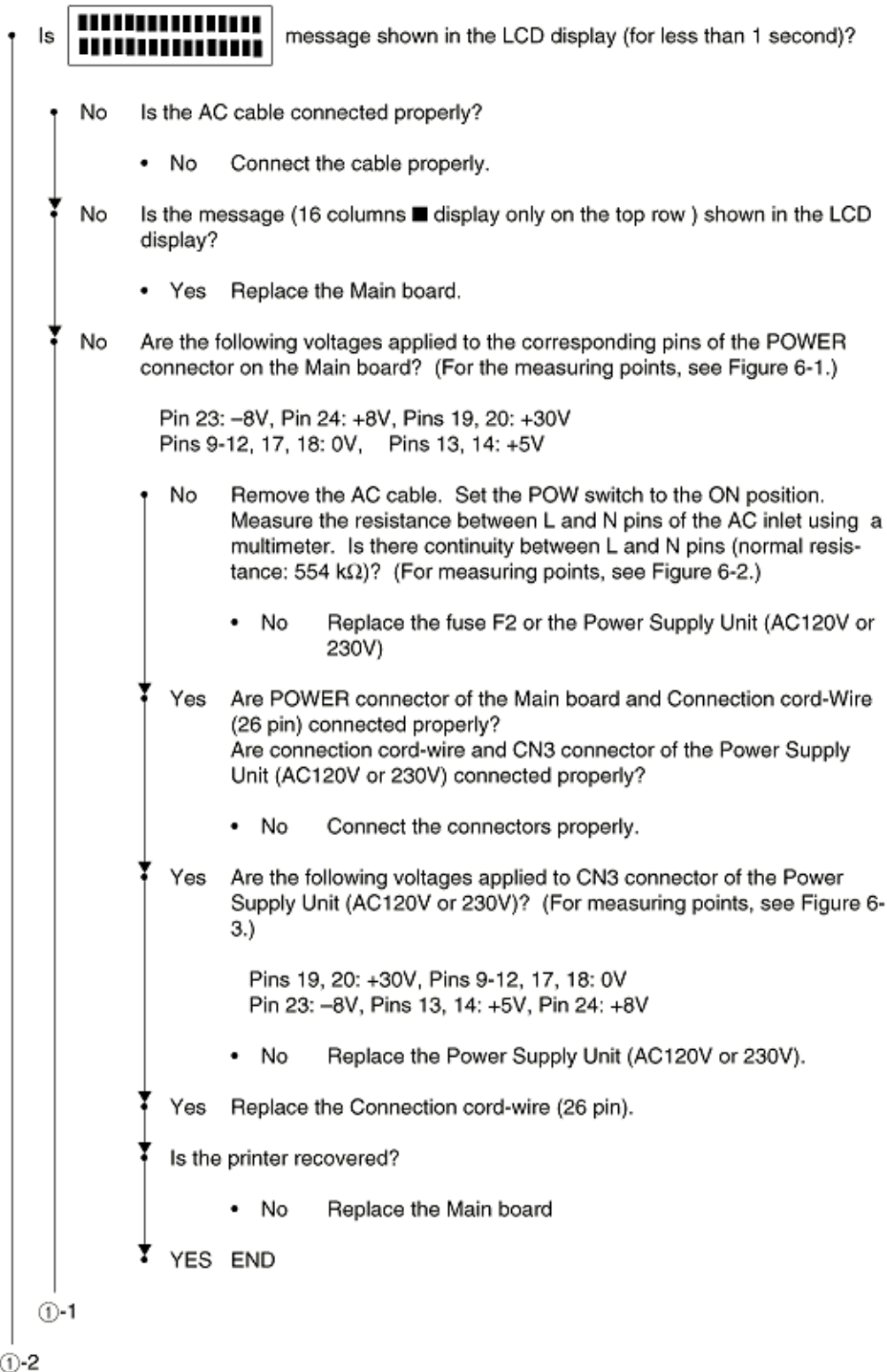

From ①-2 on the preceding page

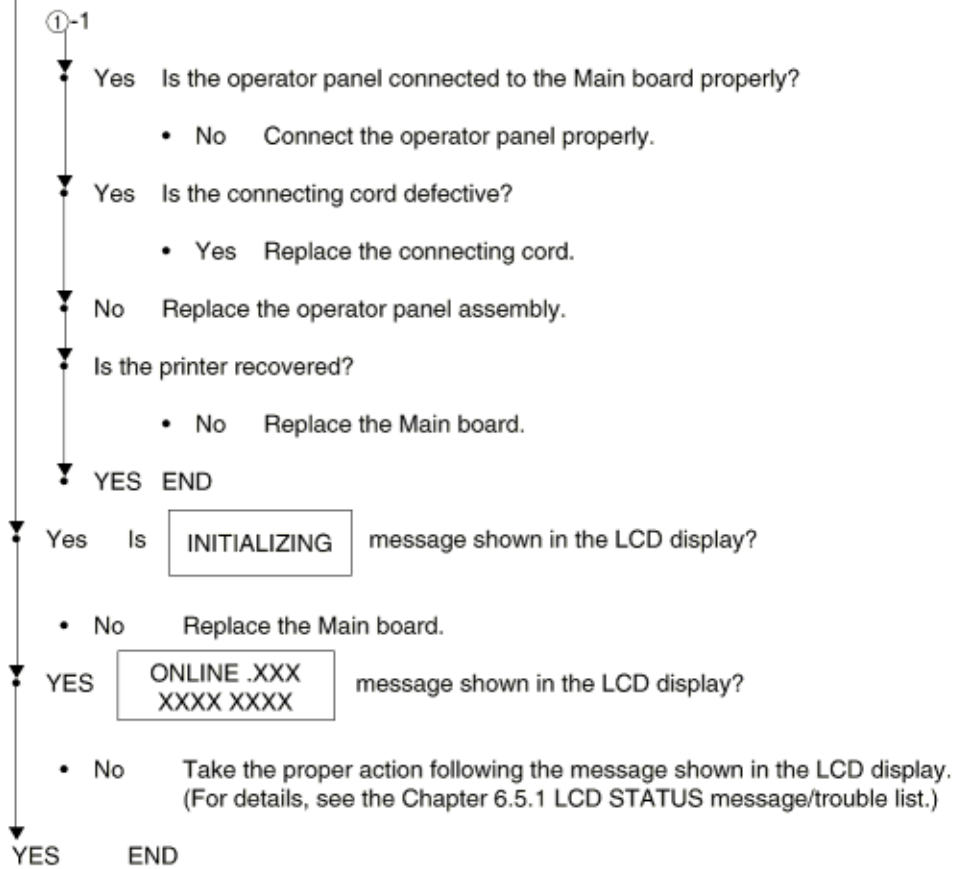

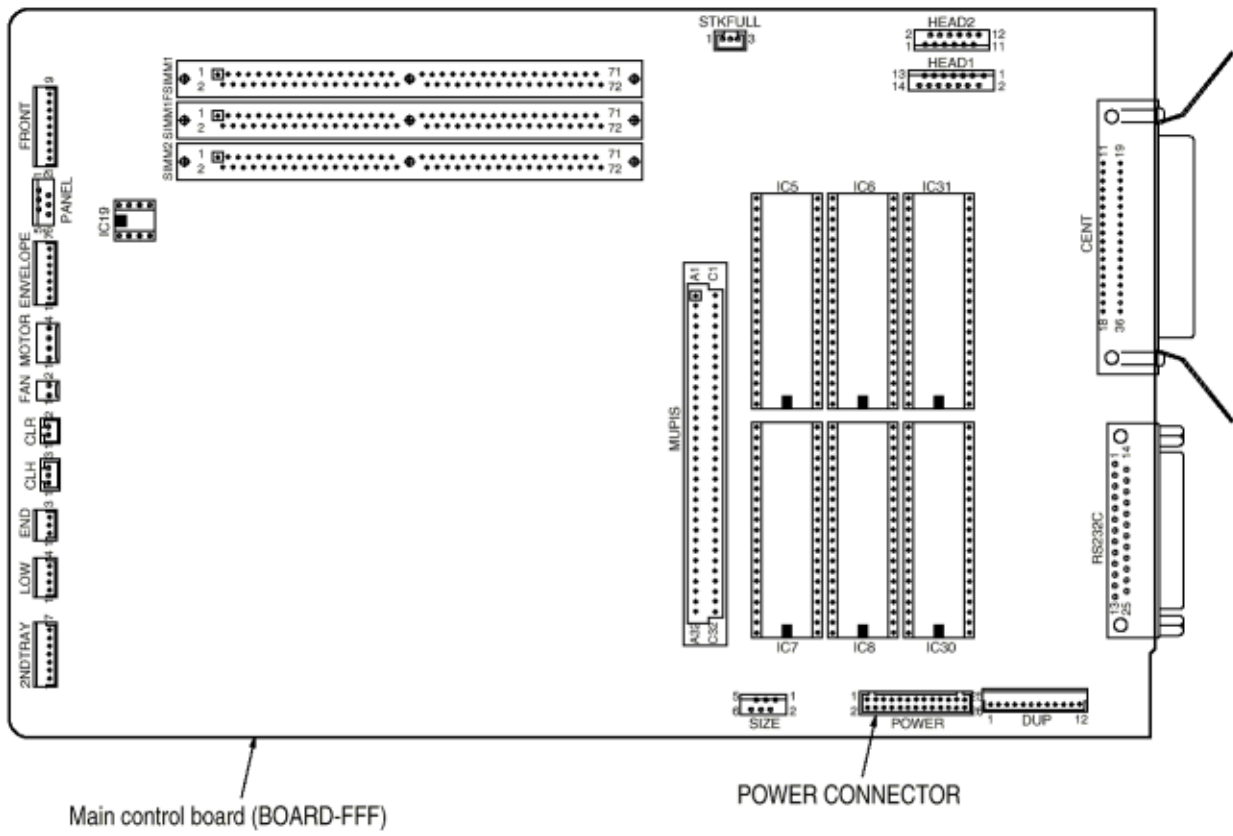

Figure 6-1 Connector and Pin Location

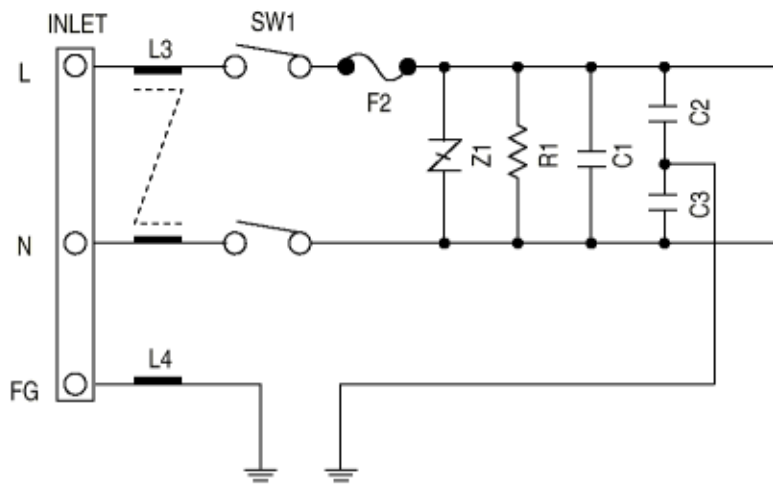

Figure 6-2 Measurement by a Multimeter

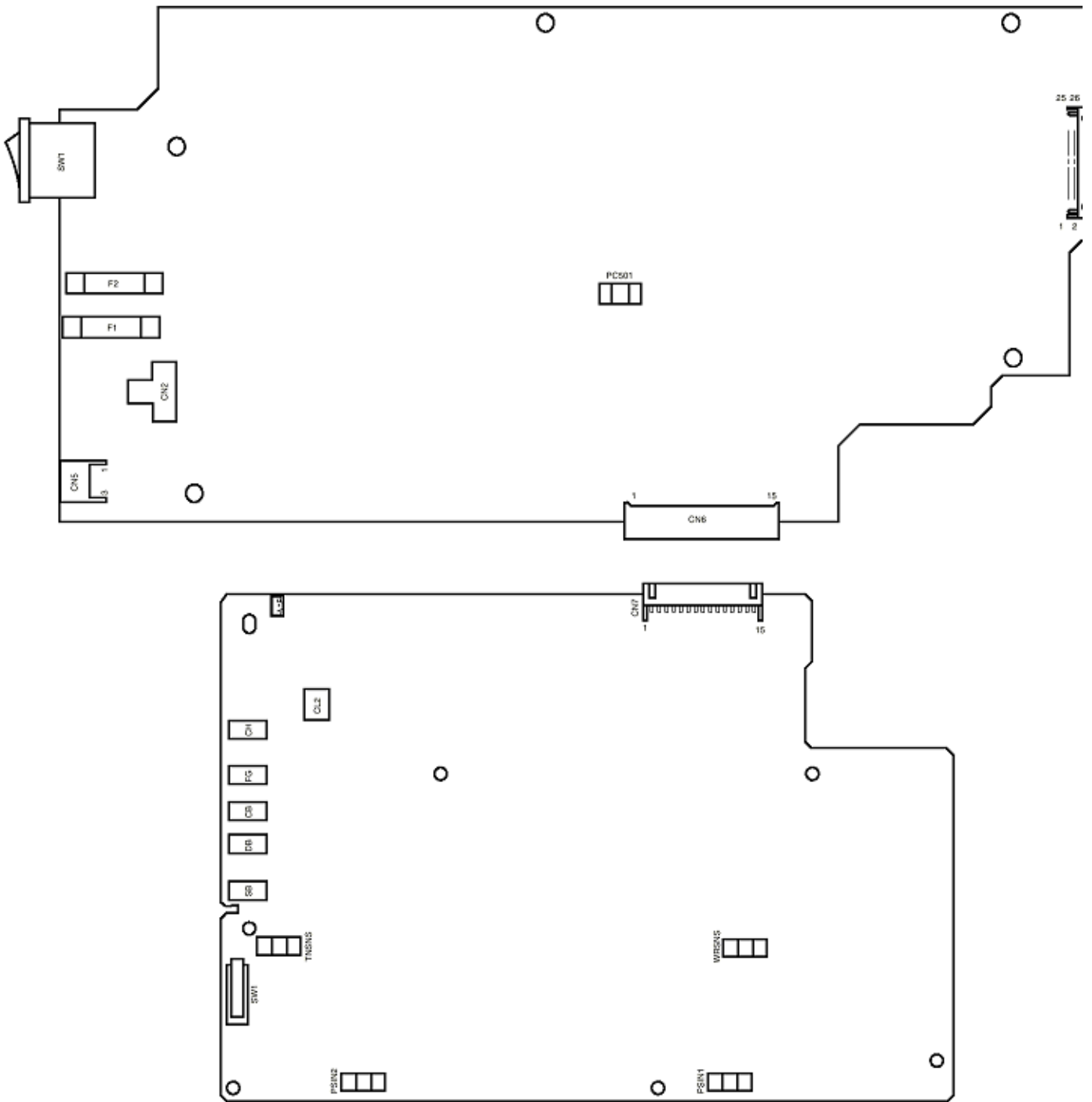

Figure 6-3 Connector and Pin Location

Copyright 1998, Okidata, Division of OKI America, Inc. All rights reserved. See the OKIDATA Business Partner Exchange (BPX) for any updates to this material. (<http://bpx.okidata.com>)



(2) Paper jams

2-1 Paper input jam (1st tray)

2-2 Paper input jam (front feeder)

2-3 Paper feed jam

2-4 Paper exit jam

Copyright 1998, Okidata, Division of OKI America, Inc. All rights reserved. See the OKIDATA Business Partner Exchange (BPX) for any updates to this material. (<http://bpx.okidata.com>)



(2)-1 Paper input jam (1st tray)

②-1 Paper input jam (1st tray)

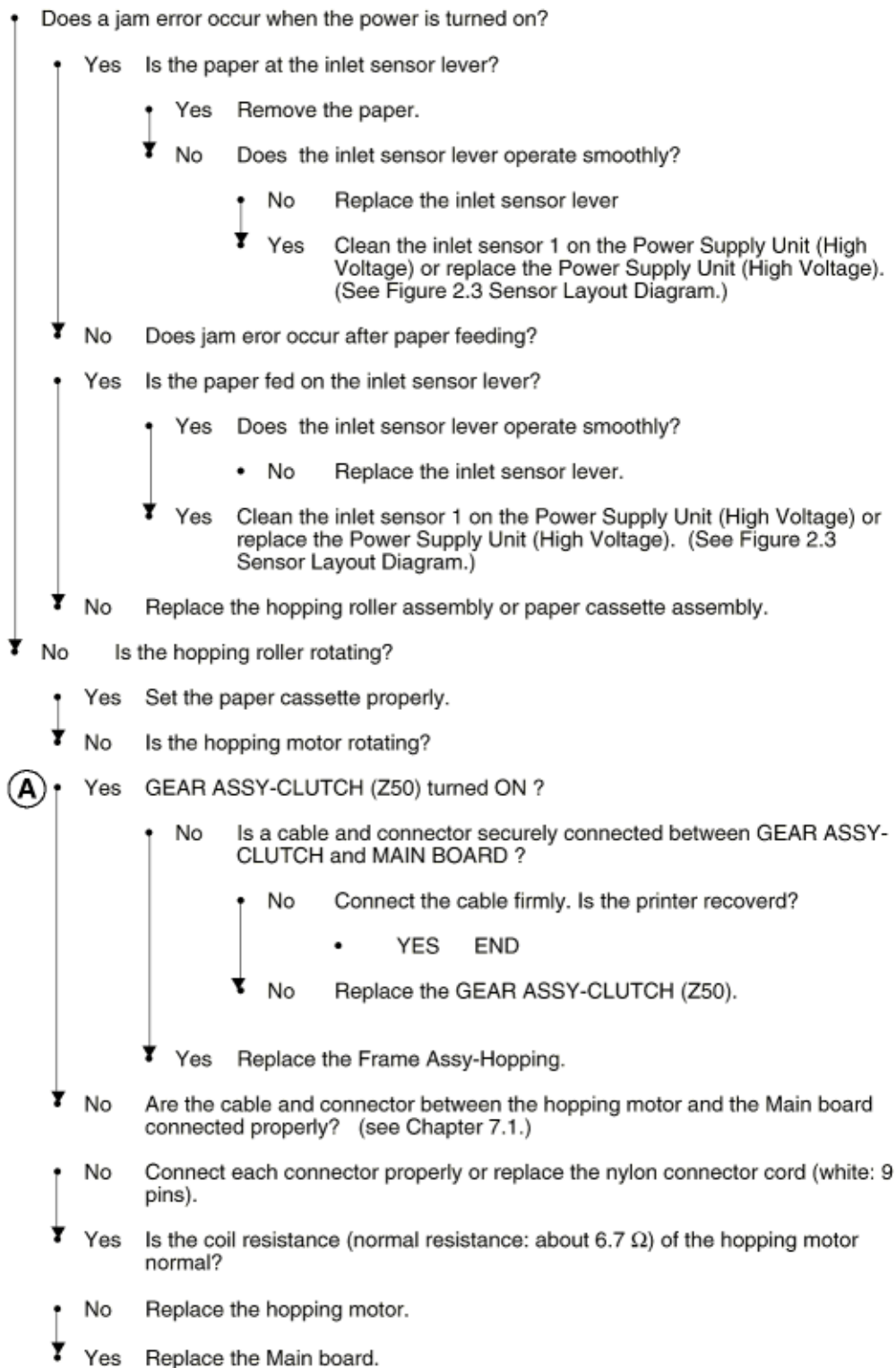

Copyright 1998, Okidata, Division of OKI America, Inc. All rights reserved. See the OKIDATA Business Partner Exchange (BPX) for any updates to this material. (<http://bpx.okidata.com>)

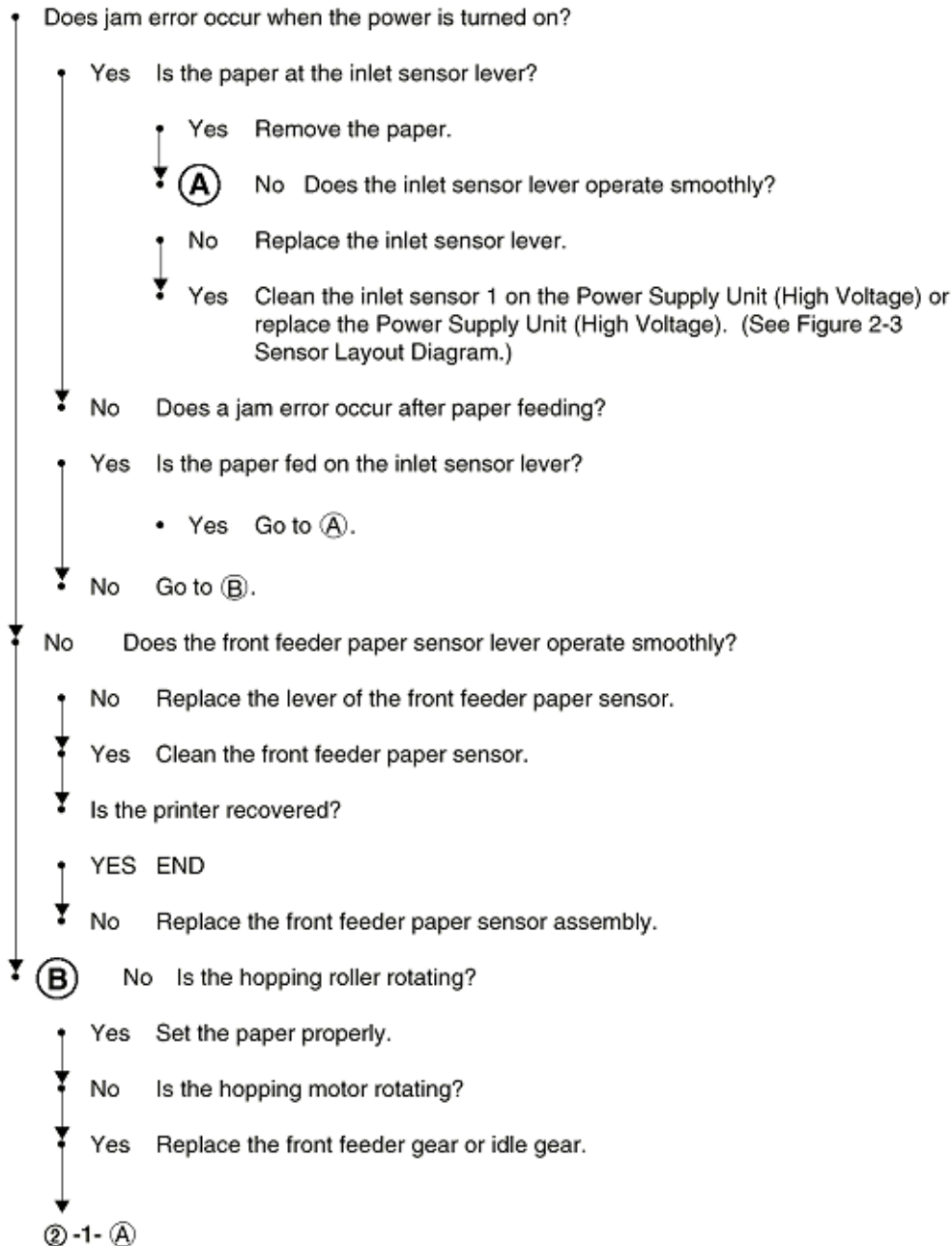
(2)-2 Paper input jam (front feeder)

(2)-3 Paper feed jam

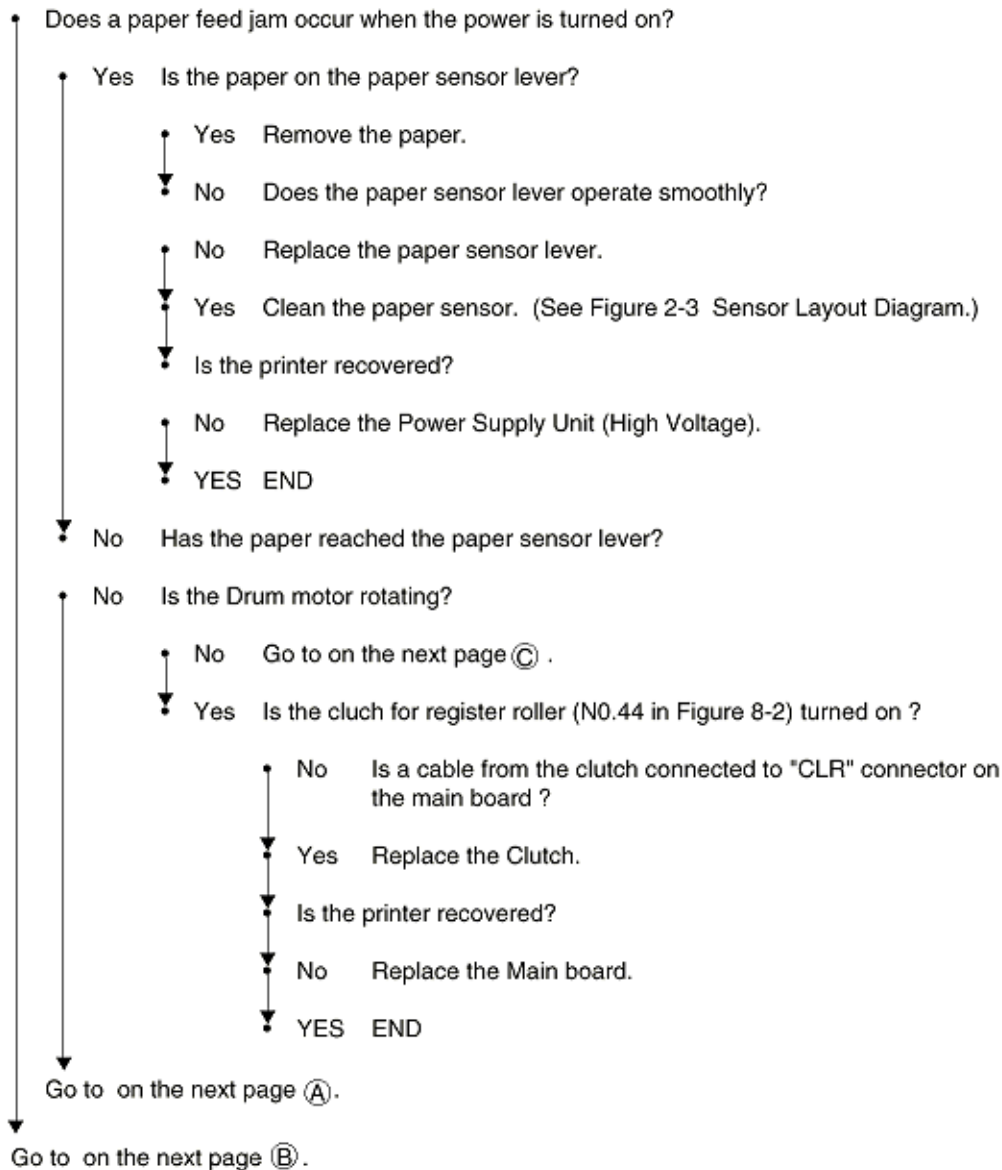

From on the preceding page (B).

From on the preceding page (A).

• Yes Is the image drum set properly?

- No Set the image drum properly.

• Yes In case of paper feed from the front feeder, check the hopping roller of the front feeder assembly. In case of paper feed from the tray, check the hopping roller assembly and the tray.

• No Has the paper reached the outlet sensor lever?

• Yes Does the outlet sensor lever operate smoothly?

- No Replace the outlet sensor lever.

• Yes Clean the outlet sensor on the Power Supply Unit (AC120V or 230V).
(See Figure 2-3 Sensor Layout Diagram.)

• Is the printer recovered?

- No Replace the Power Supply Unit (AC120V or 230V).

• YES END

• No Is the drum motor rotating?

• No (C) Is there any defective gear in the motor bracket assembly?

- Yes Replace the defective gear.

• No Are the connections for "Motor" connector on the Main board between drum motor, properly? (See Chapter 7.1)

- No Connect these connectors properly.

• No Is the coil resistance (normal resistance between pins 1 and 2, between pins 3 and 4 : 3.1 Ω) of the drum motor normal?

- No Replace the drum motor.

• Is the printer recovered?

- No Replace the Main board.

• YES END

Go to on the next page (A).

From on the preceding page (A).

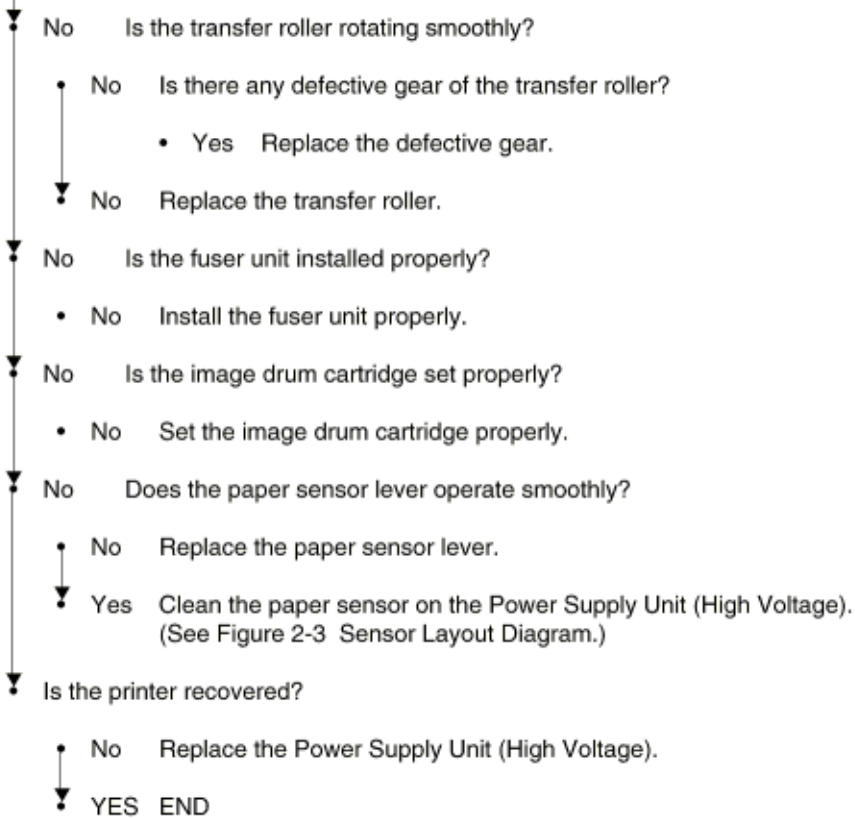

Service Guide OKIPAGE 18/18n

Chapter 6 Troubleshooting Procedures

(2)-4 Paper exit jam

- Does a paper exit jam error occur when the power is turned on?
 - YES Is the paper on the outlet sensor lever?
 - Yes Remove the paper
 - No Does the outlet sensor lever operate smoothly?
 - No Replace the outlet sensor lever.
 - Yes Clean the outlet sensor on the Power Supply Unit (AC120V or 230V). (See Figure 2-3 Sensor Layout Diagram.)
 - Is the printer recovered?
 - No Replace the Power Supply Unit (AC120V or 230V).
 - YES END
 - No Is the face-up stacker drawn out or pushed into the printer completely?
 - No Draw the face-up stacker out the printer completely or push it into the printer completely.
 - Yes Is the eject roller assembly installed properly?
 - No Install the eject roller assembly properly.
 - Yes Replace the eject roller assembly.

(3) Paper size error

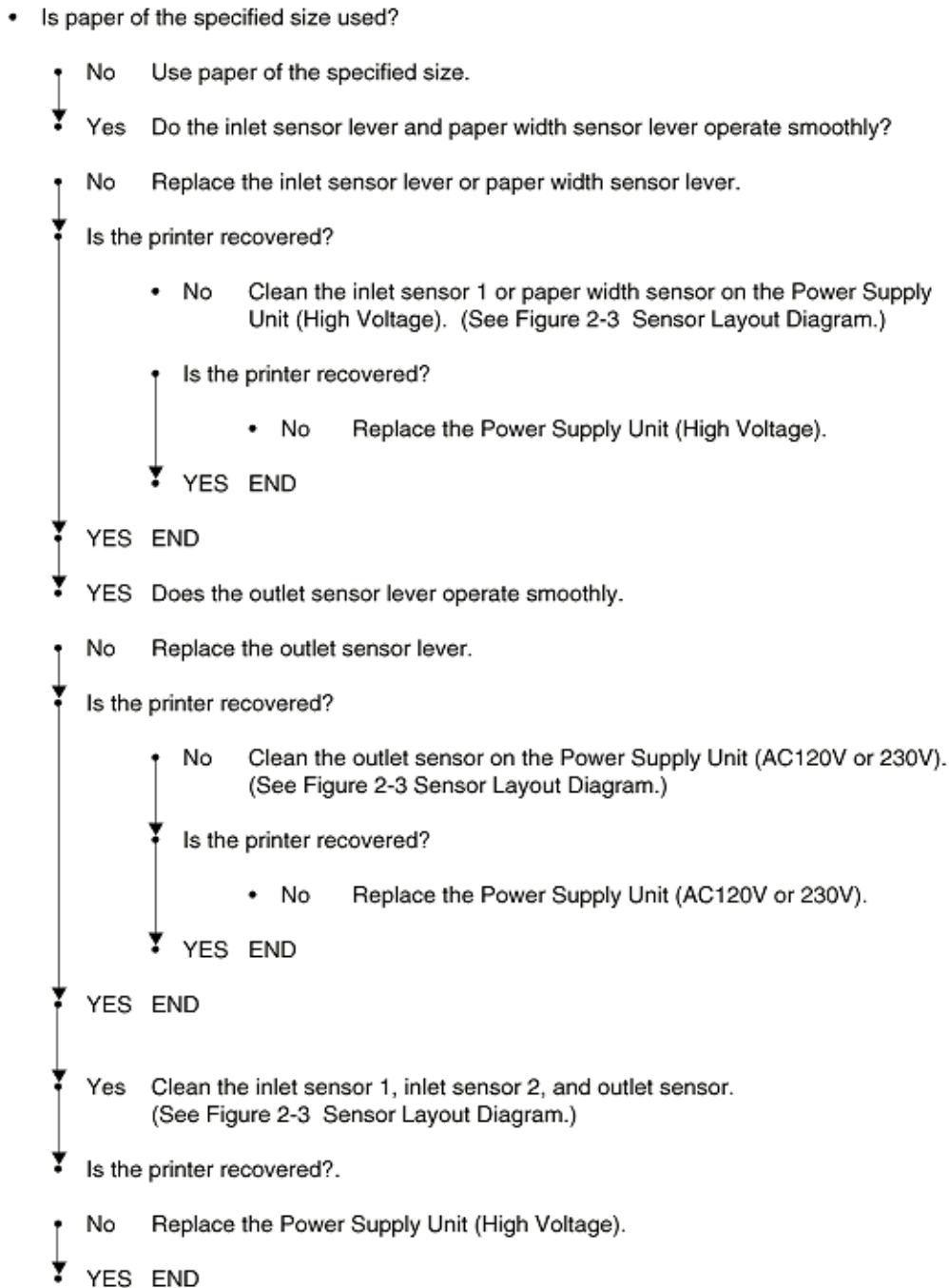

Exchange (BPX) for any updates to this material. (<http://bpx.okidata.com>)

(4) Fuser unit error (ERROR 71), (ERROR 72), (ERROR 73)

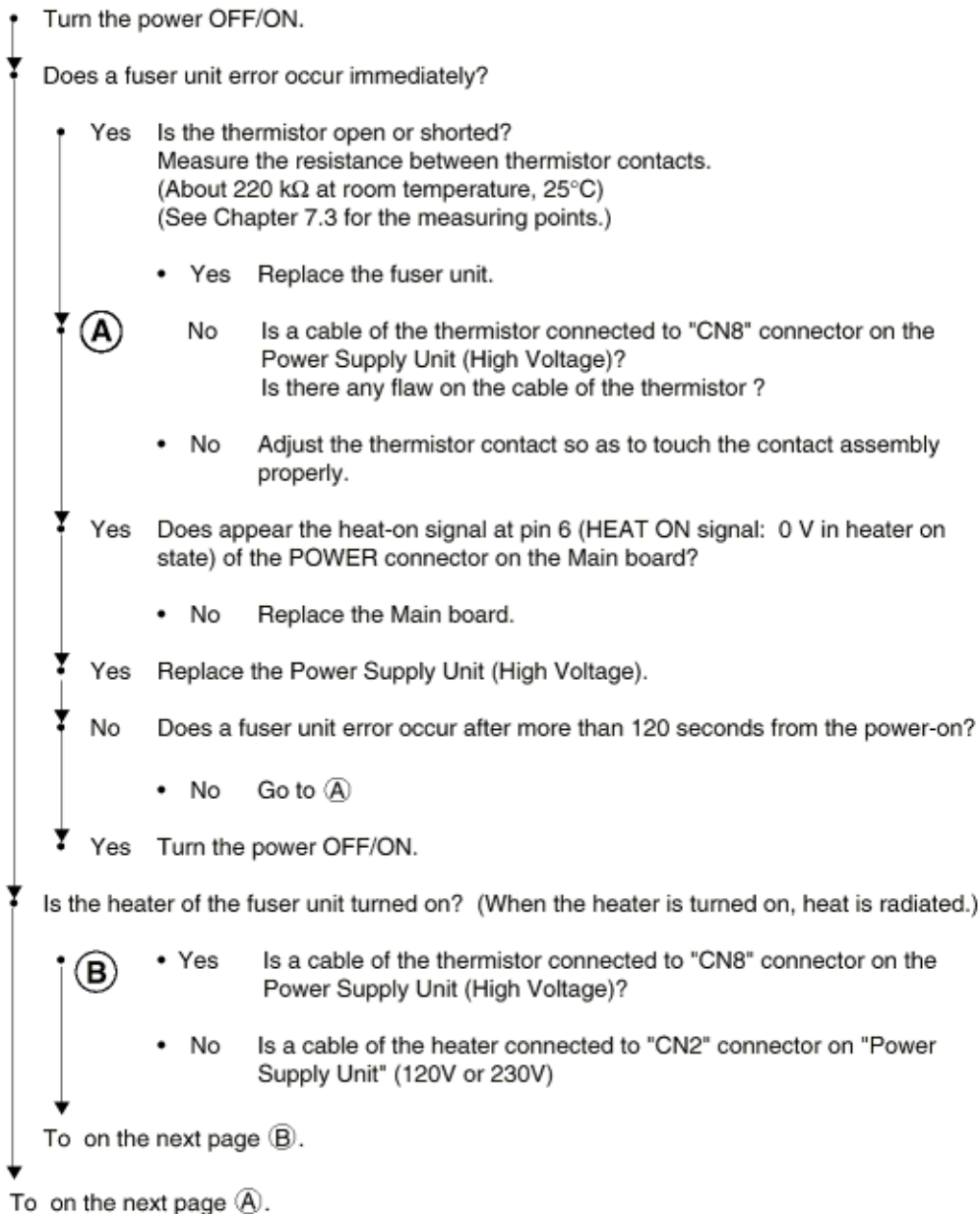

From on the preceding page (A).

From on the preceding page (B).

- Yes Replace the fuser unit.

▼ Is the printer recovered?

- No Replace the Main board.

▼ YES END

▼ No Is the heater or thermistor open?

Measure the resistance between the thermistor contacts, and between heater contacts (normal resistance: 220 k Ω (25°C) between pins 1 and 2, 1.5 Ω (120 V) and 5.8 Ω (240 V) between pins 3 and 4) (See Chapter 7.3.)

- Yes Replace the fuser unit.

▼ No Is the AC voltage applied to the CN2 connector on the Power Supply Unit (AC120V or 230V)? (See Figure 6-3)

• No Is CN2 connector connected to the Power Supply Unit (AC120V or 230V)?

- No Connect the CN2 connector to the Power Supply Unit (AC120V or 230V) properly.

▼ Yes Is Pin 6 (HEAT ON signal) of the POWER connector of the Main board turned on? (In heater on state, this pin is set to 0 V).

- No Replace the Main board.

▼ Yes Replace the Power Supply Unit (High Voltage).

▼ • YES Go to (B).



Service Guide OKIPAGE 18/18n Chapter 6 Troubleshooting Procedures

(5) I/F time-out between printer and optional tray (ERROR 81)

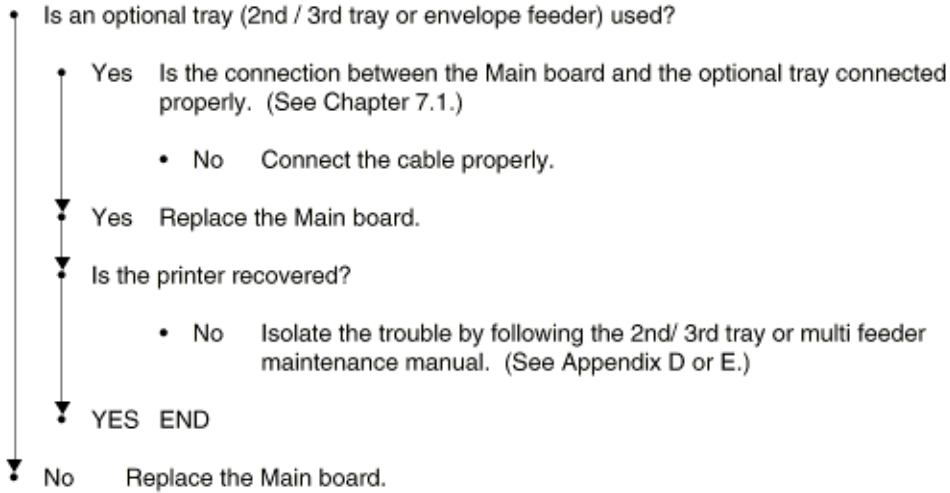



Service Guide OKIPAGE 18/18n Chapter 6 Troubleshooting Procedures

(6) I/F time-out between printer and Duplex Unit (ERROR 83)

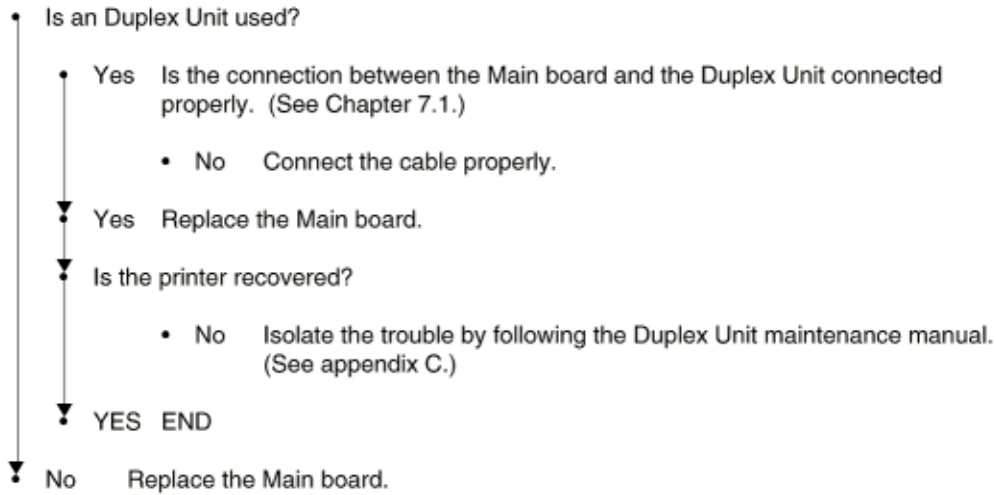



(7) I/F time-out occurs between the printer and the operator panel (ERROR 80)

- Is the connecting cord of the operator panel connected to the PANEL connector of the Main board properly? (See Chapter 7.1.)
 - No Connect the connecting cord of the operating panel to the PANEL connector of the Main board properly.
 - ▼ Yes Is the connecting cord defective?
 - Yes Replace the connecting cord.
 - ▼ No Replace the operator panel assembly.
 - ▼ Is the printer recovered?
 - No Replace the Main board.
 - ▼ YES END



(8) Message cannot be received through the parallel interface

- Is the parallel I/F ENABLE in "HOST I/F" item of Menu 1.
 - No Set the Parallel I/F to "ENABLE".
 - ▼
 - Yes Is the host set to the bidirectional communication?
 - Yes Set the parallel I/F to the bidirectional communication enable state (DISABLE → ENABLE) in menu level 2.
 - ▼
 - No Set the parallel I/F to the bidirectional communication disable state (ENABLE → DISABLE) in menu level 2.
 - ▼
 - Is the printer recovered?
 - YES END
 - ▼
 - No Is the connector of the parallel interface cable connected to the printer properly?
 - No Connect the connector of the parallel interface cable to the printer properly.
 - ▼
 - Yes Is there any defect in the cable (broken or bent pin, broken wire)?
 - Yes Replace the parallel interface cable.
 - ▼
 - No Replace the Main board or ask the user to check the hardware and software at the host side.



(9) Message cannot be received through the serial interface

- Is message ERROR HOST I/F displayed ?
 - Yes Set the RS 232C I/F ENABLE in "HOST I/F" items of Menu 1.
 - No Set the RS 232C I/F to "ENABLE".
 - No Do the following items selected for RS232C SERIAL in menu level 2 coincide with those selected at the host side ?
 - FLOW CONTROL • PARITY
 - BAUD RATE • MIN. BUSY
 - DATA BITS
 - No If the selection differs between the printer and the host, change the setting of the above items in menu level 2 so as to coincide with the setting at the host side.
 - Yes Is the connector of the serial interface cable connected to the printer properly ?
 - No Connect the connector printer properly.
 - Yes Is there any defect in the serial interface cable(broken or bent pin, broken wire) ?
 - Yes Replace the serial interface cable.
 - No Perform the loop back test using the loop test function in the system maintenance mode. (To make this test, it is necessary to form the following loop back connector. Connect the loop back connector to port instead of connecting the host.)
 - Is LOOP TEST ERROR displayed ?
 - No Replace the serial interface cable.
 - Is the printer recovered ?
 - YES END
 - No Replace the Main board.
 - Yes Replace the Main board or ask the user to check the hardware and software at the host side.

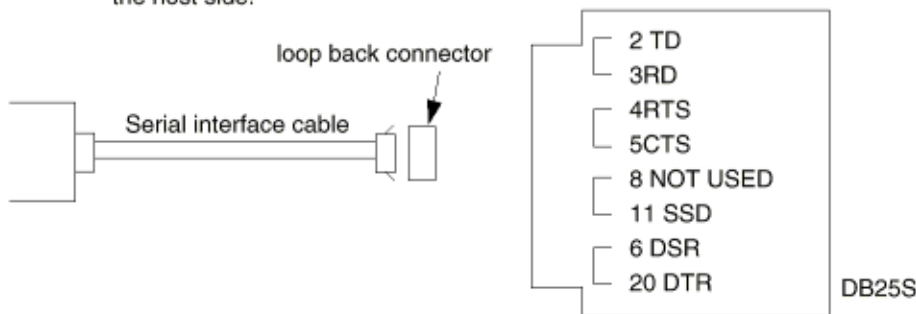

Connection method

Test connector connecting drawing

Copyright 1998, Okidata, Division of OKI America, Inc. All rights reserved. See the OKIDATA Business Partner Exchange (BPX) for any updates to this material. (<http://bpx.okidata.com>)



Service Guide OKIPAGE 18/18n Chapter 6 Troubleshooting Procedures

(10) Data cannot be received through the OKI HSP interface

- Is the interface board (option) connected to the OKI HSP interface connector on the Main board properly?
 - No Connect the interface board (option) to the OKI HSP interface connector properly.
 - Yes Is there any broken or bent pin in the interface board (option)?
 - Yes Ask the user to replace the interface board (option).
 - No Replace the Main board.
 - OK?
 - No A trouble may exist in the interface board (option), interface cable or host side. Ask the user to check these items.
-



(11) Synchronous serial I/O error (ERROR 74)

- Are POWER connector of the Main board and Connection cord-wire (Figure 8-2 No 21) properly?
Are Connection cord-wire (Figure8-2 No.21) and CN3 connector of the Power Supply Unit (AC120V or 230V) connected properly?

- No Connect the connectors properly.

- Yes Is there any flaw or breake ?

- Yes Replace the connection cord-wire.

- Yes Replace the Main board.

- Is the printer recovered?

- No Replace the Power Supply Unit (High Voltage).

- YES END

6.5.3 Image Troubleshooting

Procedures for troubleshooting for the cases of abnormal image printouts are explained below.

Figure 6-3 below shows typical abnormal images.

Problem	Flowchart number
Images are light or blurred entirely (Figure 6-4, A)	(1)
Dark background density (Figure 6-4, B)	(2)
Blank paper is output (Figure 6-4, C)	(3)
Black belts stripes in the vertical direction (Figure 6-4, D)	(4)
Cyclical defect (Figure 6-4, E)	(5)
Print voids	(6)
Poor fusing (images are blurred or peeled off when touched by hands)	(7)
White belts streaks in the vertical direction (Figure 6-4, F)	(8)
Snowy print of high density pattern (Figure 6-4, H)	(9)
Blotchy faded print (Figure 6-4, I)	(10)



A Light or blurred images entirely



B Dark background density



C Blank paper

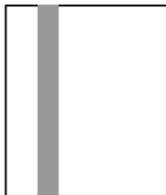

D Black vertical stripes

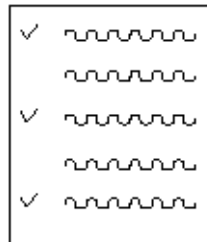

E Cyclical defect



F White vertical belts or streaks



H Snowy print of high density pattern



I Blotchy faded print

Figure 6-3 Image Problems

Copyright 1998, Okidata, Division of OKI America, Inc. All rights reserved. See the OKIDATA Business Partner Exchange (BPX) for any updates to this material. (<http://bpx.okidata.com>)

Service Guide OKIPAGE 18/18n

Chapter 6 Troubleshooting Procedures

(1) An image is light or blurred entirely

- Is toner low? (Is the TONER LOW message displayed?)
 - Yes Supply toner.
 - ▼ No Is paper of the specified grade used?
 - No Use paper of the specified grade.
 - ▼ Yes Is the lens surface of the LED head dirty?
 - Yes Clean the lens.
 - ▼ No Is the LED head installed properly? (Check connector HEAD1 (14P), HEAD2 (12P) of the Main board and PC connector on the LED head for proper connection.)
 - No Install the LED head properly.
 - ▼ Yes Is the contact plate of the transfer roller contacted with the contact assembly of the Power Supply Unit (High Voltage) properly? (See Figure 6-6.)
 - No Make the contact plate of the transfer roller contact with the Power Supply Unit (High Voltage) and Shaft of the transfer roller properly.
 - ▼ Yes Are the contact of the developing roller and the contact of the toner supply roller of the image drum cartridge contacted with the contact assembly properly? (See Figure 6-5 (A) and (B).)
 - No Adjust the contacts of the developing and toner supply roller to contact the contact assembly properly.
 - ▼ Yes Replace the transfer roller. (See 3.3.36.)
 - ▼ Has the trouble been removed?
 - YES END
 - ▼ No Replace the image drum cartridge.
 - ▼ Has the trouble been removed?
 - YES END
 - ▼ **Note:** After replacing the image drum cartridge, set the printer in the user maintenance mode by turning the power on while pressing the MENU key and reset the drum counter. (Refer to User's Manual.)
 - ▼ No Replace the Main board or Power Supply Unit (High Voltage).
-

Copyright 1998, Okidata, Division of OKI America, Inc. All rights reserved. See the OKIDATA Business Partner Exchange (BPX) for any updates to this material. (<http://bpx.okidata.com>)

(2) Dark background density

- Has the image drum been exposed to external light?
 - Yes Mount the image drum in the printer and wait for about 30 minutes.
- ▼ No Is the heat roller of the fusing unit dirty?
 - Yes Clean the heat roller.
- ▼ No Is the contact of the cleaning roller of the image drum cartridge contacted with a contact assembly properly? (See Figure 6-5 (C).)
 - No Adjust the contact of the cleaning roller to contact the contact assembly properly.
- ▼ Yes Replace the image drum cartridge.
- ▼ Has the trouble been removed?
 - YES END
- ▼ No Replace the Main board or Power Supply Unit (High Voltage).

Note: After replacing the image drum cartridge, set the printer in the user maintenance mode by turning the power on while pressing the MENU key, and reset the drum counter. (Refer to User's Manual.)

Service Guide OKIPAGE 18/18n

Chapter 6 Troubleshooting Procedures

(3) Black paper is output

- Is the LED head connected properly? (Check connector HEAD1 (14P), HEAD2 (12p) on the Main board and PC connector on the LED head.)
 - No Connect the LED head properly or replace the head cable.
- ▼ Yes Is the contact of the image drum cartridge contacted with the ground contact properly. (See Figure 6-5 (D).)
 - No Check the ground contact of the image drum cartridge.
- ▼ Yes Check the connectors HEAD1 (14P) and HEAD2 (12P)
 - No Replace the LED head.
- ▼ Yes Replace the connector
- ▼ Has the trouble been removed.
 - YES END
- ▼ No Replace the Main board or Power Supply Unit (High Voltage).

Note: After replacing the LED head, set the printer in the engine maintenance mode by turning the power on while pressing the FORM FEED and ENTER keys. Set the LED head drive time. (Refer to Section 4.2.)



(4) Black belts or stripes in the vertical direction

- Replace the image drum cartridge.
- Has the trouble been removed?
 - YES END
 - Note:** After replacing the image drum cartridge, set the printer in the user maintenance mode by turning the power on while pressing the MENU key, and reset the drum counter, (Refer to User's Manual.)
- ▼ No Replace the LED head.
- ▼ Has the trouble been removed?
 - YES END
 - Note:** After replacing the LED head, set the printer in the engine maintenance mode by turning the power on while pressing the FORM FEED and ENTER keys. Set the LED head drive time. (Refer to Section 4.2.)
- ▼ No Replace the Main board or Power Supply Unit (High Voltage).



Service Guide OKIPAGE 18/18n

Chapter 6 Troubleshooting Procedures

(5) Cyclic error

	Cycle	Remedy
Image Drum	3.71" (94.2 mm)	Clean or replace the image drum unit.
Developing roller	2.05" (52.1 mm)	Replace the image drum cartridge.
Toner supply roller	3.24" (82.24 mm)	Replace the image drum cartridge.
Charging roller	1.37" (34.7 mm)	Replace the image drum cartridge.
Cleaning roller	1.17" (29.8 mm)	Replace the image drum cartridge.
Transfer roller	2.28" (58 mm)	Replace the transfer roller.
Heat roller	3.46" (88 mm)	Replace the fusing unit assy.
Pressure roller B	3.46" (88 mm)	Replace pressure roller.

Notes:

1. After replacing the image drum cartridge, set the printer in the user maintenance mode by turning the power on while pressing the MENU key, and reset the drum counter. (Refer to User's Manual.)
- 2 After replacing the fusing unit assy, set the printer in the engine maintenance mode by turning the power on while pressing the FORM FEED and ENTER keys, and reset the fuser counter. (Refer to See 4.1.)

(6) Print voids

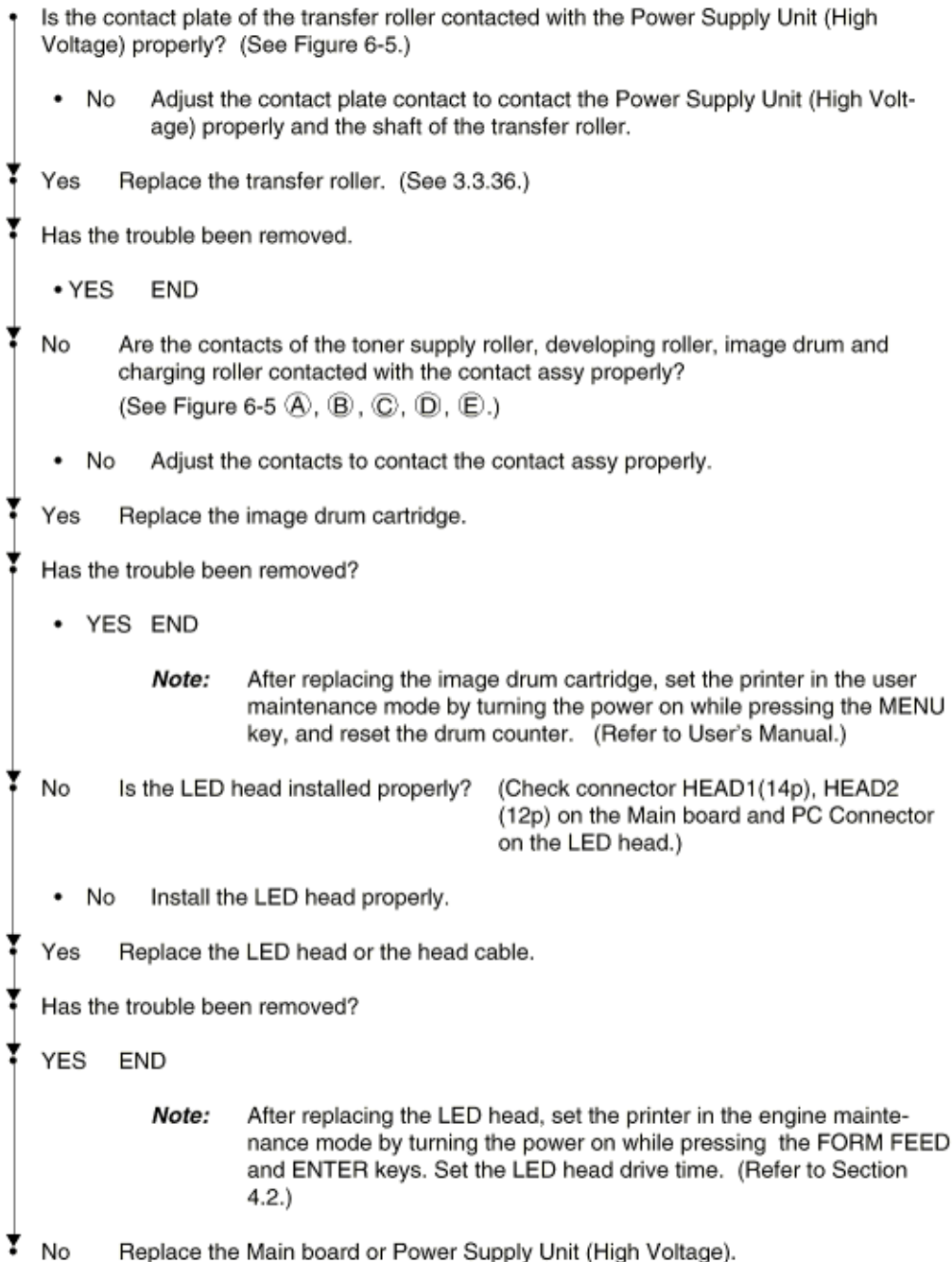

Exchange (BPX) for any updates to this material. (<http://bpx.okidata.com>)



Service Guide OKIPAGE 18/18n Chapter 6 Troubleshooting Procedures

(7) Poor fusing

- Is paper of the specified grade used?
 - No Use paper of the specified grade.
- ▼ Yes Is the spring of the back-up roller normal?
 - No Replace the spring.
- ▼ Yes Is the contact of the fusing unit assy contacted with the contact assy properly?
 - No Adjust the contact of the fusing unit assy to contact the contact assembly properly.
- ▼ Yes Replace the fusing unit assy.
- ▼ Has the trouble been removed?
 - YES END
- ▼ No Replace the Main board or Power Supply Unit (High Voltage).

|

Service Guide OKIPAGE 18/18n

Chapter 6 Troubleshooting Procedures

(8) White belts or streaks in the vertical direction

- Are the LED lens dirty?
 - Yes Clean the LED lens.
 - ▼ No Is the contact plate of the transfer roller contacted with the Power Supply Unit (High Voltage) properly? (See Figure 6-6.)
 - No Make the contact plate contact with the Power Supply Unit (High Voltage) properly.
 - ▼ Yes Replace the transfer roller. (See 3.3.36.)
 - ▼ Has the trouble been removed?
 - YES END
 - ▼ No Is the LED head installed properly? (Check connector HEAD1 (14p), HEAD2 (12p) on the Main board and PC connector on the LED head.)
 - No Install the LED head properly.
 - ▼ Yes Replace the LED head.
 - ▼ Has the trouble been removed?
 - YES END

Note: After replacing the LED head, set the printer in the engine maintenance mode by turning the power on while pressing the FORM FEED and ENTER keys. Set the LED head drive time. (Refer to Section 4.2.)
 - ▼ Yes Replace the image drum cartridge.
 - ▼ Has the trouble been removed?
 - YES END

Note: After replacing the image drum cartridge, set the printer in the user maintenance mode by turning the power on while pressing the MENU key. Reset the drum counter. (Refer to User's Manual.)
 - ▼ No Replace the Main board or Power Supply Unit (High Voltage).
-



(9) Snowy print of high density pattern

- Is toner low?
 - Yes Supply toner.
- ▼ No Is paper of the specified grade used?
 - No Use paper of the specified grade.
- ▼ Yes Is the lens of the LED head dirty?
 - Yes Clear the lens.
- ▼ No Is the LED head installed properly?
 - No Install the LED head properly.
- ▼ Yes Increase the printer setting number ($\pm 0 \rightarrow +1$) (Refer to User's manual.)



(10) Blotchy faded print

- Is toner low?
 - Yes Supply toner.
- ▼ No Is paper of the specified grade used?
 - No Use paper of the specified grade.
- ▼ Yes Is the lens of the LED head dirty?
 - Yes Clear the lens.
- ▼ No Is the LED head installed properly?
 - No Install the LED head properly.
- ▼ Yes Decrease the printer setting number ($\pm 0 \rightarrow -1$) (Refer to User's manual.)

Service Guide OKIPAGE 18/18n Chapter 6 Troubleshooting Procedures

Contents - Figure 6-5

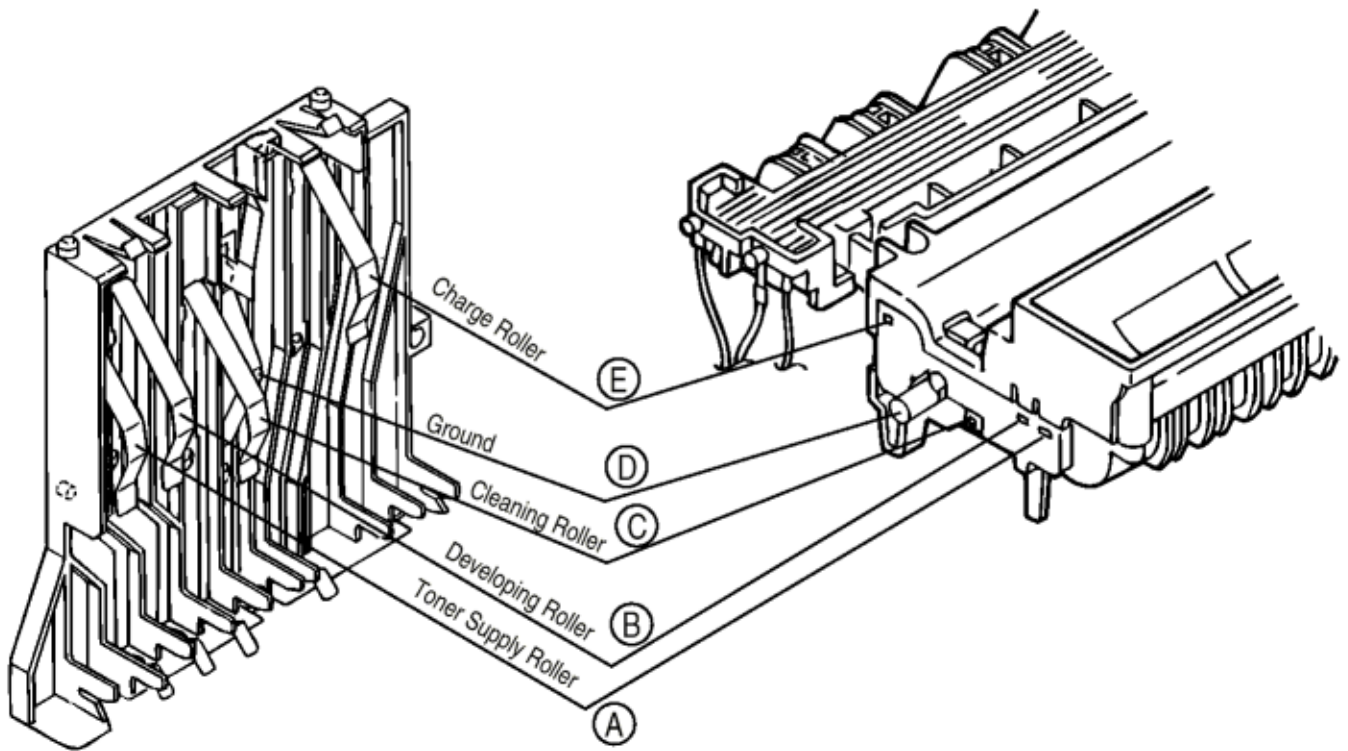

Contents - Figure 6-6

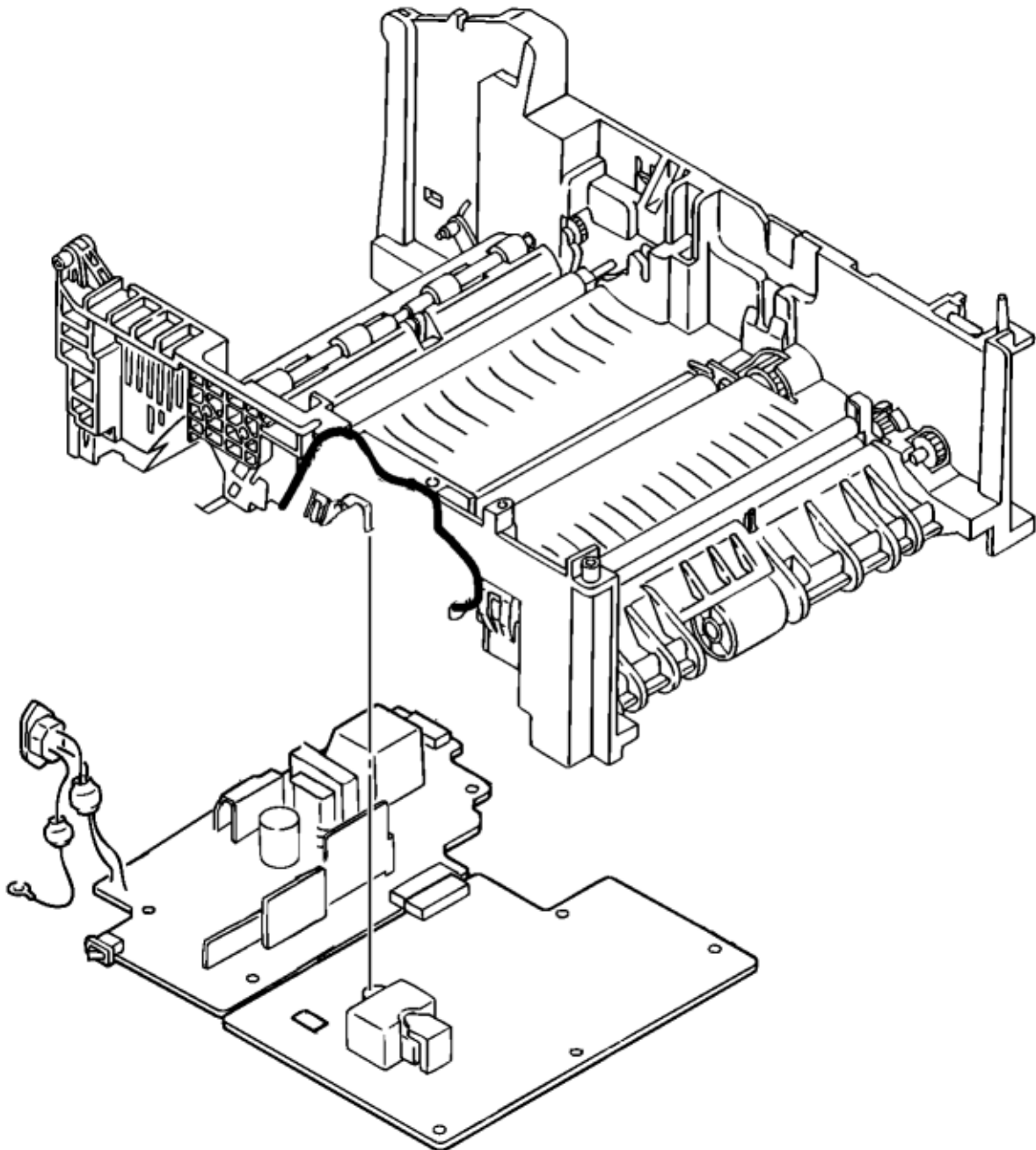



7.1 Interconnect Signal Diagram

Copyright 1998, Okidata, Division of OKI America, Inc. All rights reserved. See the OKIDATA Business Partner Exchange (BPX) for any updates to this material. (<http://bpx.okidata.com>)



Service Guide OKIPAGE 18/18n Chapter 7 Wiring Diagram

Page: 110

7.2 PCB Layout

7.2.1 Main Control Board (BOARD - FFF)

7.2.2 Power supply board (AC120V/230V)

7.2.3 Power supply board (High voltage)

7.2.4 Flash ROM module (BOARD-FSL or FSL-2))

Copyright 1998, Okidata, Division of OKI America, Inc. All rights reserved. See the OKIDATA Business Partner Exchange (BPX) for any updates to this material. (<http://bpx.okidata.com>)



Service Guide OKIPAGE 18/18n
Chapter 7 Wiring Diagram

7.2.1 Main Control Board (HBY PCB)

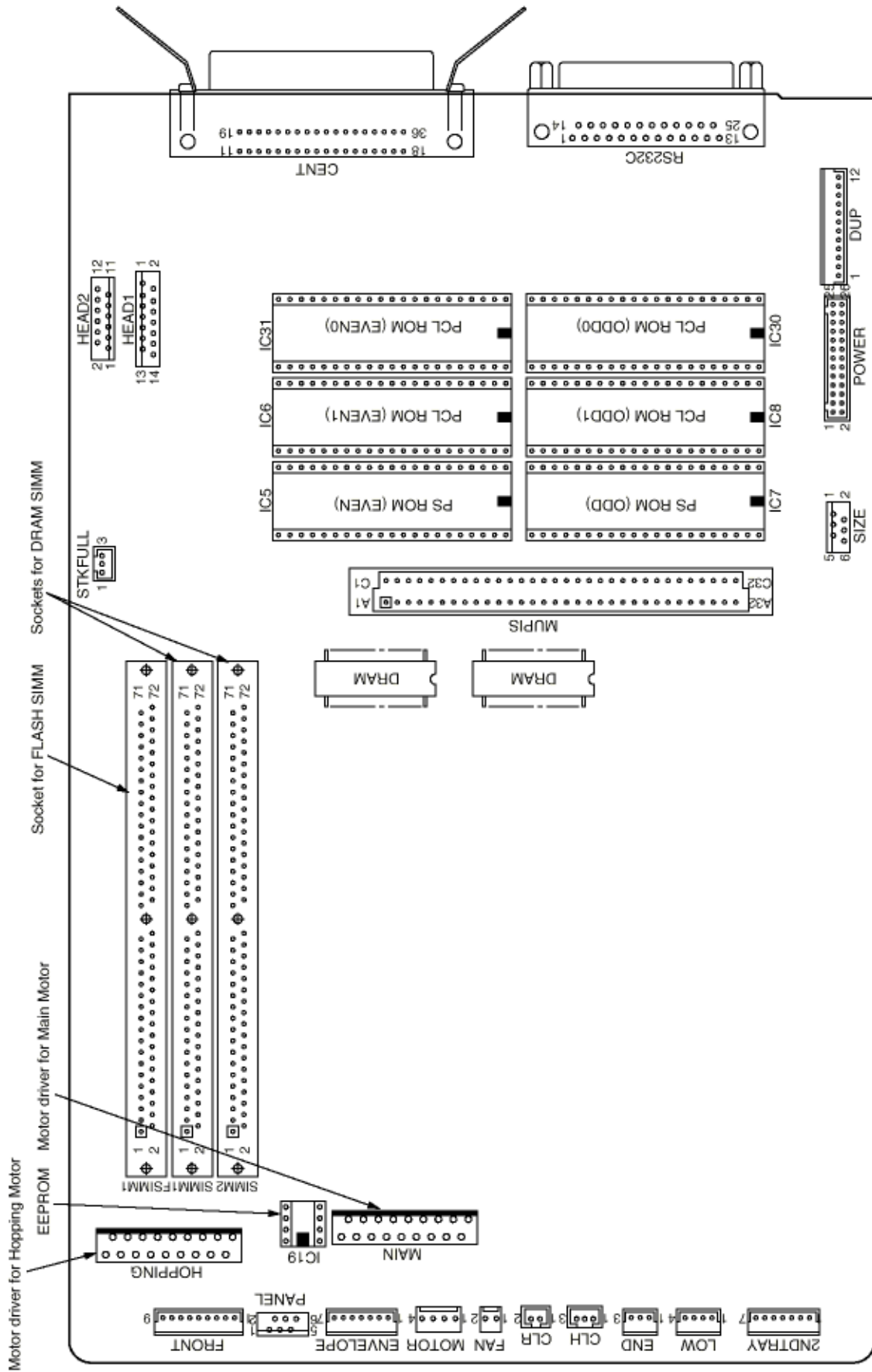

Copyright 1998, Okidata, Division of OKI America, Inc. All rights reserved. See the OKIDATA Business Partner Exchange (BPX) for any updates to this material. (<http://bpx.okidata.com>)



Service Guide OKIPAGE 18/18n Chapter 7 Wiring Diagram

7.2.2 Power Supply Board (120V/230V)

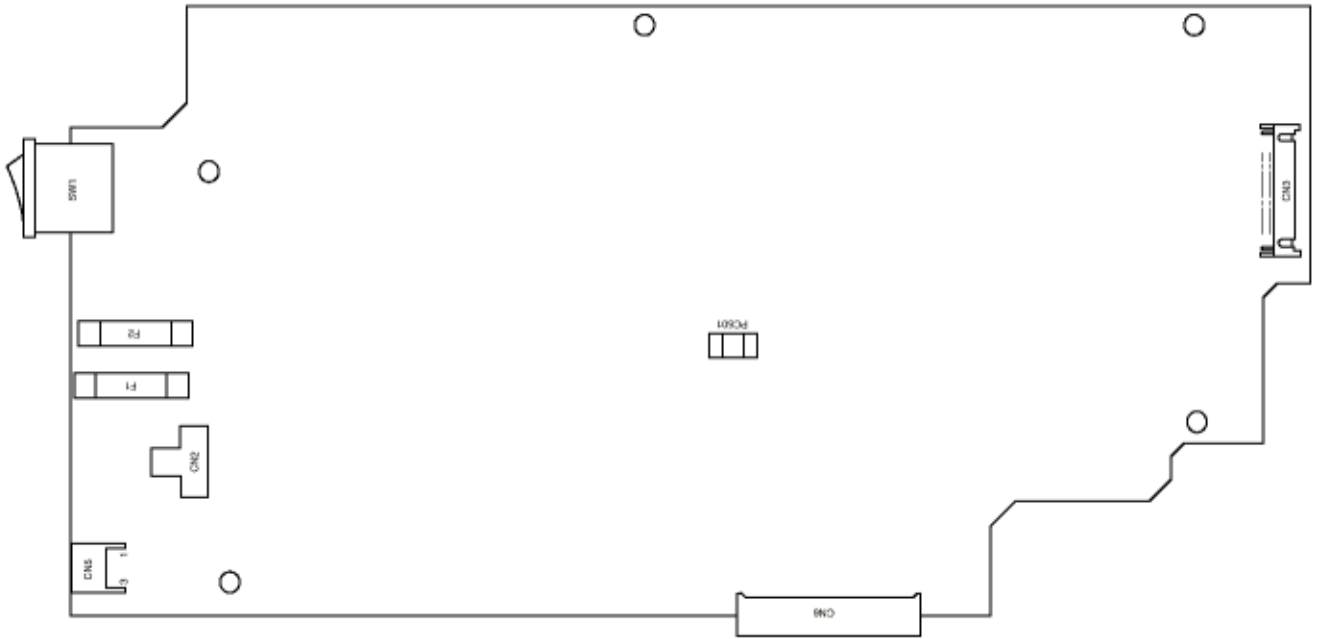

Copyright 1998, Okidata, Division of OKI America, Inc. All rights reserved. See the OKIDATA Business Partner Exchange (BPX) for any updates to this material. (<http://bpx.okidata.com>)

7.2.3 Power supply board (High voltage)

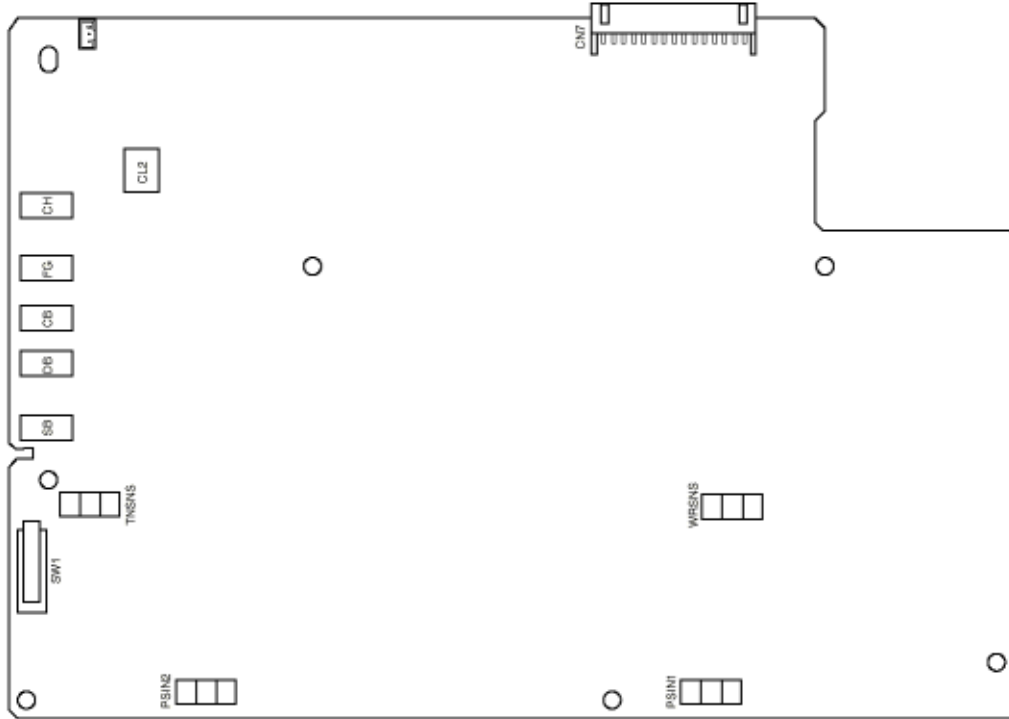

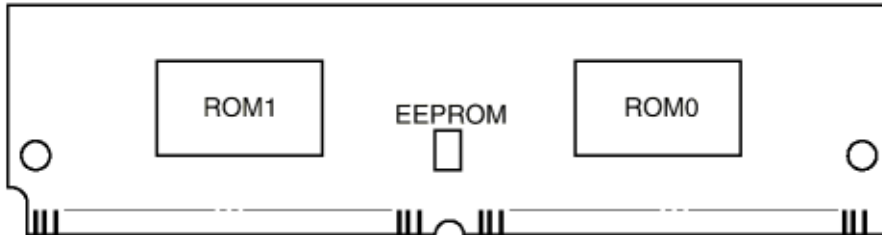
7.2.4 Flash ROM module (BOARD-FSL or BOARD-FSL-2)

Copyright 1998, Okidata, Division of OKI America, Inc. All rights reserved. See the OKIDATA Business Partner Exchange (BPX) for any updates to this material. (<http://bpx.okidata.com>)

7.3 Resistance Check

Unit	Circuit Diagram	Illustration	Resistance
Motor - Main			Between pins 1 & 2: 3.1 Ohms Between pins 3 & 4: 3.1 Ohms
Fusing Unit	<p>to "CN2" connector on the Power Supply Unit (AC120V or 230V)</p> <p>to "CN8" connector on the Power Supply Unit (High Voltage)</p>		Between pins 1 & 2: 6.7 Ohms Between pins 3 & 4: 6.7 Ohms
Hopping motor			Between pins 1 & 2: 3.1 Ohms Between pins 3 & 4: 3.1 Ohms
Fan			

Copyright 1998, Okidata, Division of OKI America, Inc. All rights reserved. See the OKIDATA Business Partner Exchange (BPX) for any updates to this material. (<http://bpx.okidata.com>)

Service Guide OKIPAGE 18/18n Chapter 7 Wiring Diagram

7.4 Program Font/ROM Location

(1) In case of EP ROM or OTP ROM

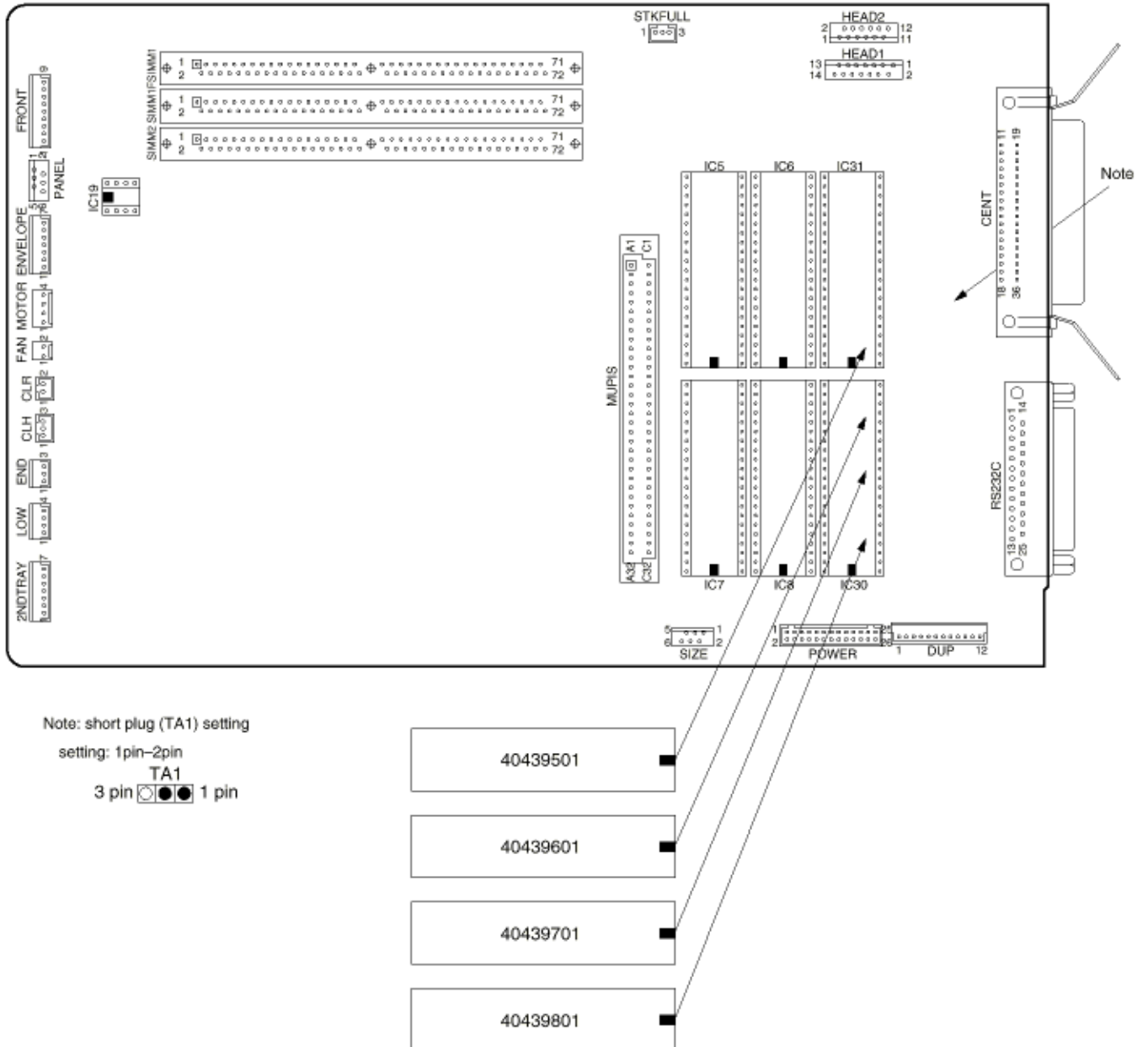

(2) In case of MASK ROM

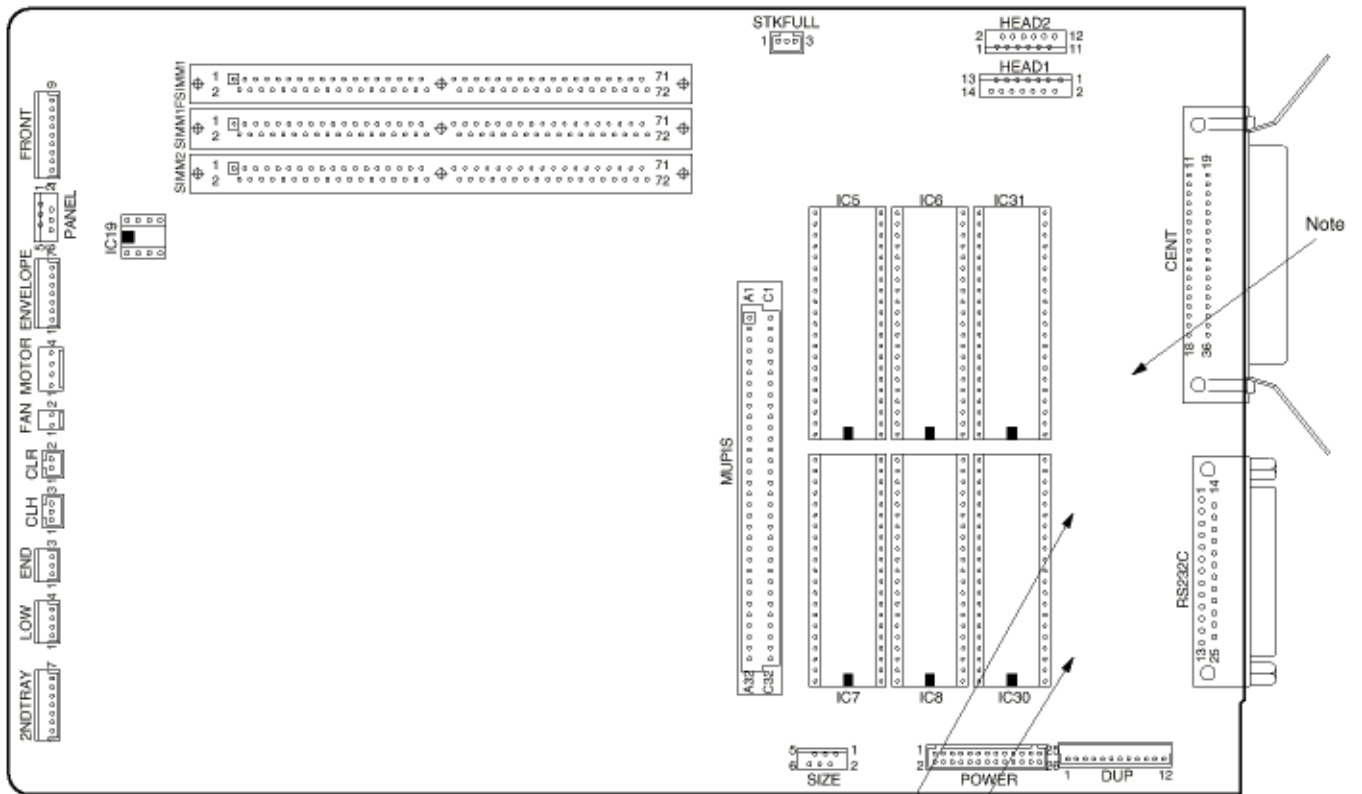

Note: short plug (TA1) setting
 setting: 2pin-3pin
 TA1
 3 pin 1 pin

- MX23C2410PC-10-*** *** : 075 or 080
- MX23C2410PC-10-*** *** : 074 or 079



Service Guide OKIPAGE 18/18n
Chapter 8 Parts List

Figure 8-1 Printer Unit

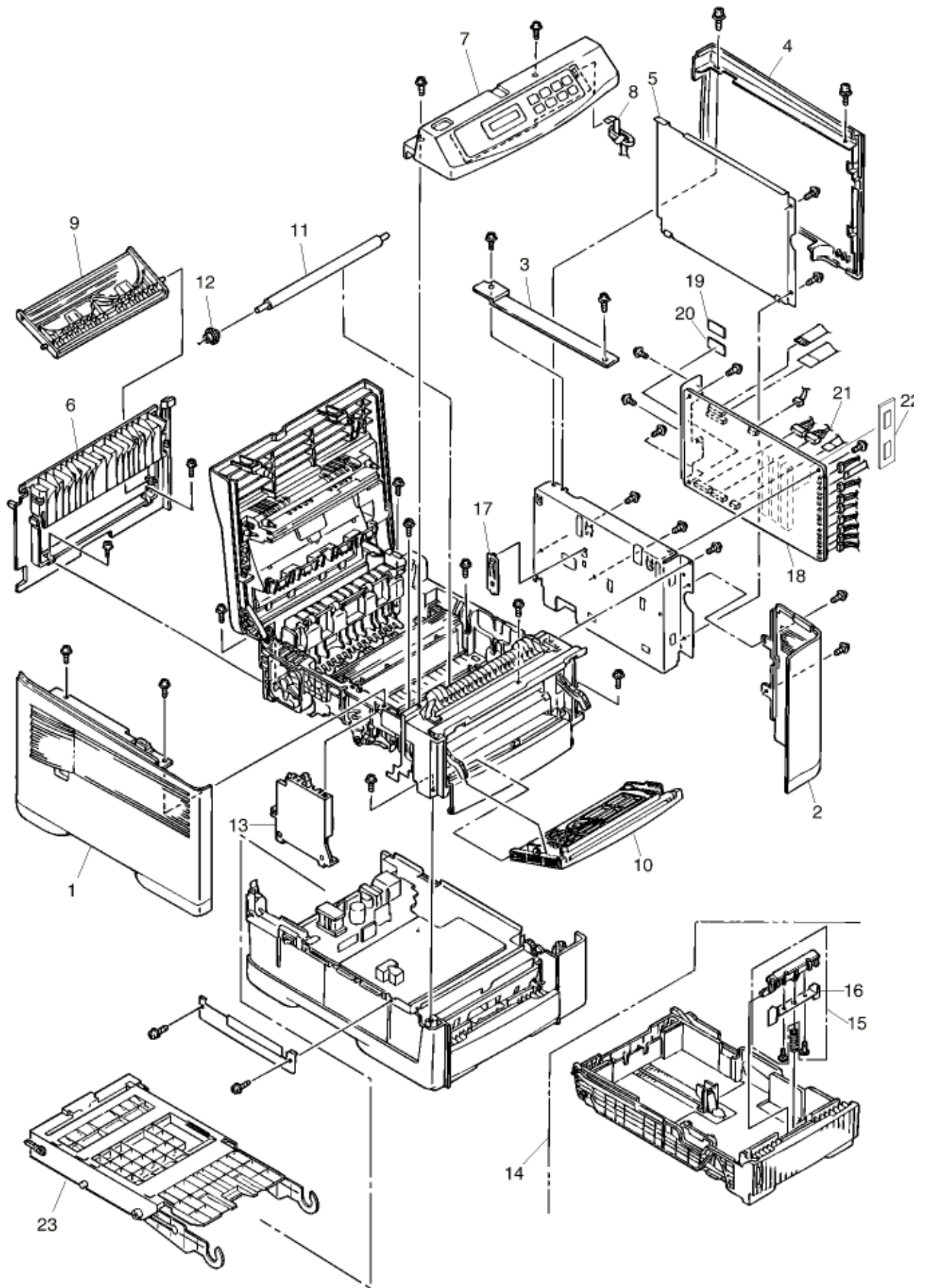

No.	Part #	Name	Qty	Remarks
1	40441001	Cover - Side (L) Assy	1	
2	40304101	Cover - Side (R)	1	
3	40304401	Cover - Frame	1	
4	40304301	Cover - Side (I/F)	1	
5	40323401	Plate - Shield	1	
6	40304001	Cover - Rear	1	
7	40304508	Frame - OP Panel Assy	1	
8	56635407	Operation Panel Cable	1	
9	50108201	Face-up Stacker Assy	1	
10	40441301	Manual Feed Assy	1	
11	40027002	Roller - Transfer	1	
12	51234901	TR Gear	1	
13	40378001	Contact Assy	1	
14	40378401	CASE Assy - Cassette	1	
15	40927901	Frame Assy - Separation	1	
16	40496001	PLATE - Damper	1	
17	53346401	Earth Plate BK (R)	1	
18	40946904	Board - FFF	1	
20	40295701	Connection Cord Wire (Power Supply)	1	
23	40931301	Duplex Unit	1	

Copyright 1998, Okidata, Division of OKI America, Inc. All rights reserved. See the OKIDATA Business Partner Exchange (BPX) for any updates to this material. (<http://bpx.okidata.com>)

Service Guide OKIPAGE 18/18n Chapter 8 Parts List

Figure 8-2 Frame - Main Unit

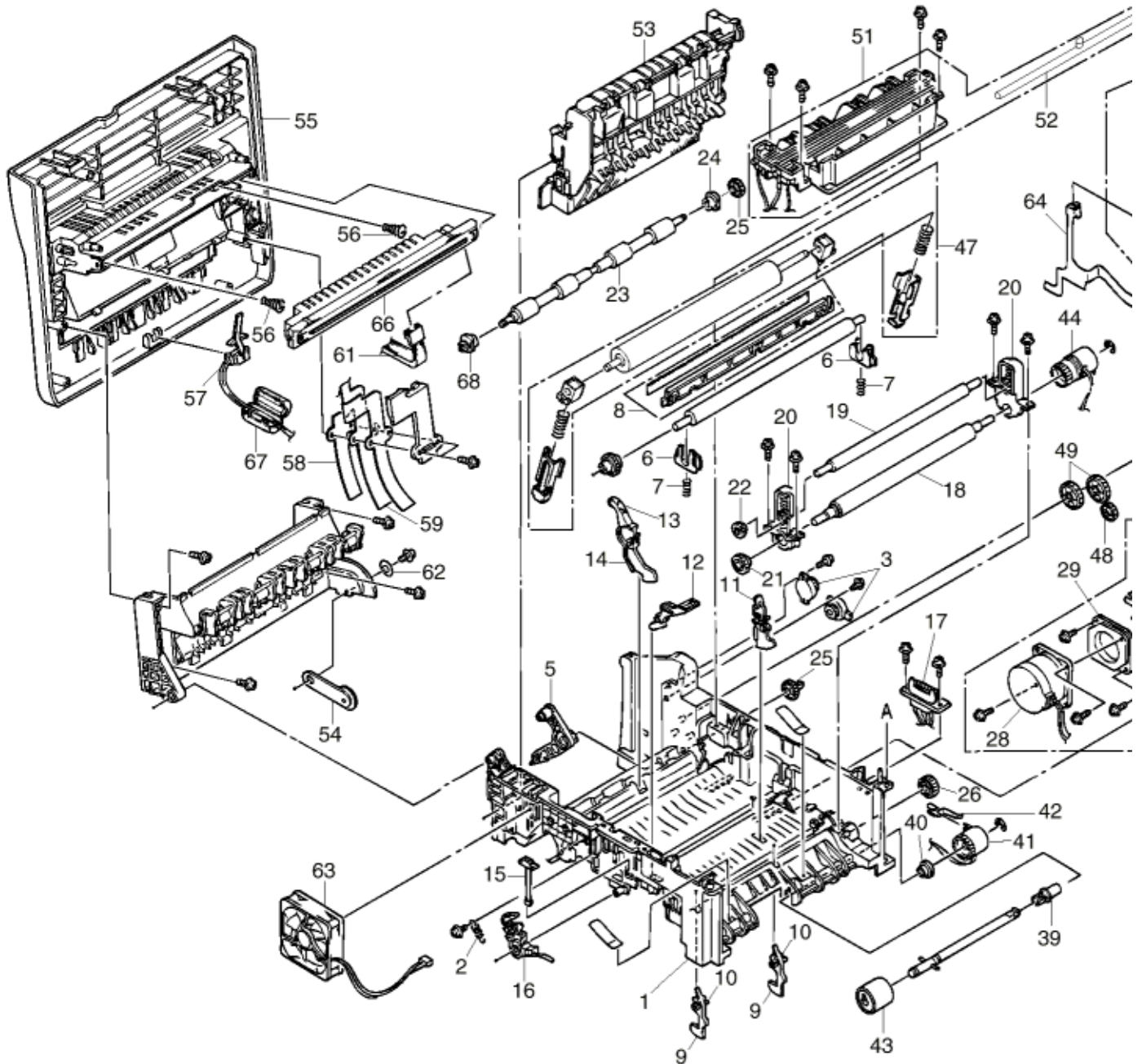

No.	Part #	Name	Qty	Remarks
1	40596901	Frame Assy - Main	1	For Maintenance
2	50928306	Spring	1	
3	51229401	Damper	1	
4			1	
5	40315801	Lever - Separator	1	
6	51608501	TR Bearing	1	
7	50928602	TR Spring R	1	
8	40299701	Guide Assy - Discharge	1	
9	40032901	Sensor - In	1	
10	40033001	Spring-In Sensor	1	
11	50807901	Write Sensor Lever	1	
12	50807801	Toner Sensor Lever (Adhesive)	1	
13	40583801	Lever Assy - Out sensor	1	
14	40324001	Spring - Out sensor	1	
15	51113301	EP Lock Shaft	1	
16	50807501	EP Rock Lever L Assy	1	
17	40597001	Code Assy - Front	1	
18	40301601	Roller - Regist	1	
19	40301701	Roller - Pressure	1	
20	40614401	Bearing Assy - Registration	1	
21	40301801	Gear - Regist	1	
22	40301901	Gear - Pressure	1	
23	40323901	Roller - Feed (C)	1	
24	51607301	Bush	1	
25	40316301	Gear - Roller (C)	1	
26	40302401	Gear - Idle (K)	1	
27	40298201	Motor Assy - Main	1	
28	40298301	Motor - Main	1	
29	40298801	Plate - Damper	1	
30	40332901	Gear - Idle A	1	
31	40320301	Gear - Idle B	1	
32	40299201	Gear - Idle C	1	
33	40302201	Gear - Idle D	1	
34	40299301	Gear - Idle E	1	
35	40299401	Gear - Idle F	1	
36	40299501	Gear - Idle G	1	
37	40299601	Gear - Idle H	1	
38	40302301	Gear - Idle J	1	
39	40313501	Bearing - Plastic (Feed)	1	
40	51608201	Bearing	1	
41	40371501	Gear Assy - Clutch (Z50)	1	
42	40432301	Plate - FG (1st)	1	
43	40313201	Roller Assy - Feed	1	
44	40371601	Gear Assy - Clutch (Z40)	1	
45	50807301	EP Rock Lever R	1	
46	50928401	EP Lock Spring	1	
47	40301001	Roller Assy - BK	1	
48	40316101	Gear - Idle (EA)	1	
49	40316201	Gear - idle (EB)	1	
50	40302501	Lever - Back up release	1	
51	40929101	Heat - Assy (A4 120V)	1	
52			1	
53	40307401	Guide Assy - Eject	1	
54	53073101	Damper Arm (Caulking0	1	
55	40587001	Stacker Assy (For Maintenance)	1	
56	50932001	Head Spring	1	
57	40365401	Sensor - Stack Full	1	
58	40409201	Film - Guide	1	
59	40409301	Film - FG	1	
60	53073401	Cable Cover	1	

61	40450501	Head Cable Assy	1	
62	50516701	Washer	1	
63	5656701	DC Fan Motor (92)	1	
64	56511201	Plate - FG (F)	1	
65	40307201	Feeder Unit - Front	1	
66	40443301	LED - Head	1	
67	55506001	ZCAT 1325-0530A R Core	1	
68	51609401	Bearing	1	

Copyright 1998, Okidata, Division of OKI America, Inc. All rights reserved. See the OKIDATA Business Partner Exchange (BPX) for any updates to this material. (<http://bpx.okidata.com>)



Service Guide OKIPAGE 18/18n
Chapter 8 Parts List

Figure 8-3 Base Unit

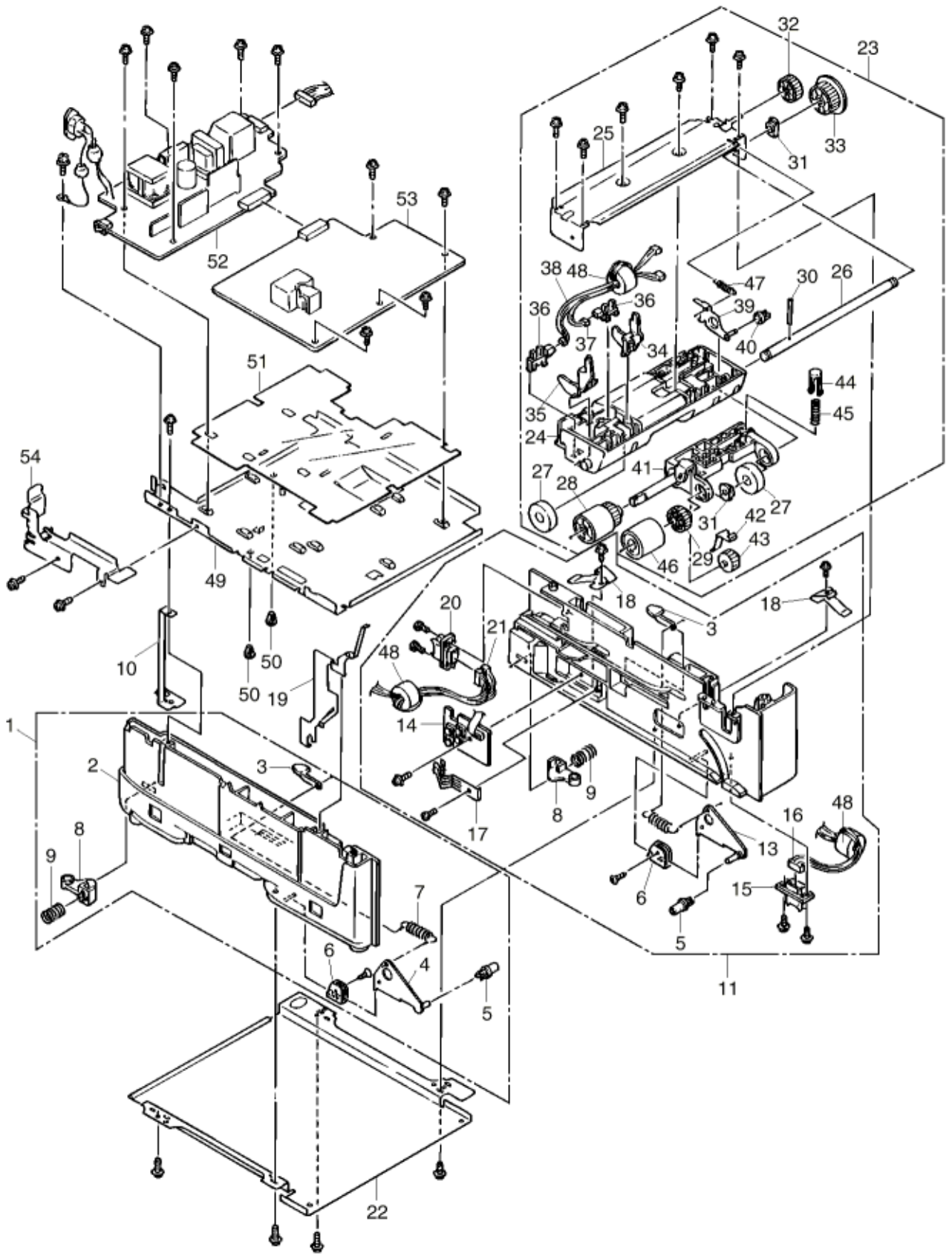

No.	Part #	Name	Qty	Remarks
1	40377601	Guide assy - Cassette (L)	1	
2	40597101	Guide - Cassette (L)	1	For Maintenance
3	51500301	Pull Block	2	
4	40349102	Lever - Link (Caulking)	1	
5	40349701	Roller - Link	2	
6	50516801	Rink Support	2	
7	40928101	Spring - Sheet	2	
8	50607201	Cassette Stopper	2	
9	50928801	Pressure Coil Spring	2	
10	40445601	Earth Plate L	1	
11	40377701	Guide Assy - Cassette (R)	1	
12	40597201	Guide - Cassette (R)	1	
13	40349101	Lever - Link (Caulking)	1	
14	40368302	Board PXC-2	1	
15	56731640	Connector	1	
16	56730803	Nylon Connector Cord	1	
17	50928901	Detector Spring	1	
18	40389801	Plate - Earth (Bottom)	2	
19	40518501	Plate - Earth (Link)	1	
20	56731641	Connector (IMSA-9714N-14B)	1	
21	40375001	Connection Code - Wire	1	
22	40989101	Plate - Bottom	1	
23	40377801	Frame Assy - Hopping	1	
24	40597301	Frame - Hopping	1	
25	40322101	Plate - Hopping (caulking)	1	
26	40317401	Shaft - Hopping	1	
27	40442501	Roller - Guide	2	
28	40371301	Roller - Assy - Hopping	1	
29	40317601	Gear - Z38	1	
30	50608101	Knock Pin	1	
31	51608901	ADF Bearing	2	
32	40325401	Gear - Z58	1	
33	40325301	Gear - Z42	1	
34	40317901	Lever - Paper end	1	
35	40318001	Lever - Paper near end	1	
36	50410001	FX050 Photo Sensor	2	
37	40375202	Connection Code - Wire	1	To Paper End
38	40375302	Connection Code - Wire	1	To Paper Near End
39	40337301	Lever - Sub roller (caulking)	1	
40	40337601	Roller - Link (Sub)	1	
41	40433701	Bracket-Sub roller (Press fitting)	1	
42	40358101	Plate - Planet	1	
43	40317701	Gear - Planet (z28)	1	
44	40367101	Bracket - Spring (Sub)	1	
45	40928201	Spring - Sub Roller	1	
46	40313201	Roller Assy - Feed	1	
47	40371901	Spring - Release	1	
48	55506101	TR-23-11-14 R Core	3	
49	40298001	Plate - Base	1	
50	40494601	Spacer - Card (KGPS-5RF)	2	
51	40298101	Film - Insulation	1	
52	40159901	Power supply Unit (120V)	1	
53	40160301	Power supply Unit (High voltage)	1	
54	40307301	Brack - AC	1	

Copyright 1998, Okidata, Division of OKI America, Inc. All rights reserved. See the OKIDATA Business Partner Exchange (BPX) for any updates to this material. (<http://bpx.okidata.com>)



Service Guide OKIPAGE 18/18n

Chapter A Centronics Parallel Interface

Parallel Interface

(1) Connector

- Printer side: 36 receptacle
Type: 57RE-40360-830B-D29 (made by DDK) or equivalent
- Cable side: 36-pin plug
Type: 57-30360 (made by DDK) or equivalent

(2) Cable

- Cable length: 6 feet (1.8 m) max.
(a shielded cable composed of twisted pair wires is recommended for noise prevention).

3) Table of Parallel I/F signals

Pin No.	Signal Name	Signal Direction	Compatible	Nibble	ECP
1	DATA STROBE	--> PR	nStrobe	Host Clk	Host Clk
2 - 9	DATA BIT - n	--> PR		Data 1 (LSB) ~ 8 (MSB)	
10	ACKNOWLEDGE	<-- PR	nAck	Ptrclk	PeriphClk
11	BUSY	<-- PR	Busy	PtrBusy	PeriphAck
12	PAPER END	<-- PR	Perror	AckDataReq	nAck Reverse
13	SELECT	<-- PR	Select	Xflag	Xflag
14	AUTO FEED	--> PR	nAutoFb	HostBusy	HostAck
15	-				
16	0V			Signal Ground	
17	CHASSIS GROUND			Chassis Ground	
18	+5V	,__ PR		+5V supply (50mA)	
19	0V			Signal Ground	
20~27	0V	-		Signal Ground	
28	0V	-		Signal Ground	
29	0V	-		Signal Ground	
30	0V	-		Signal Ground	
31	INPUT PRIME	--> PR	nInit	nInit	nPeriphRequest
32	FAULT	<-- PR	nFault	nDataAvail	nPeriphRequest
33	0V			-	
34	-			-	
35	HILEVEL	<-- PR		High Level	
36	SEL-IN	-- PR	nSelectIn	1284 Active	184 Active

- Connector pin arrangement

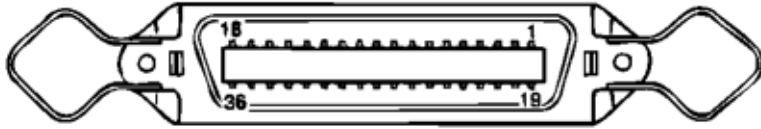

(4) Signal level

- LOW : 0 V to +0.8 V
- HIGH: +2.4 V to 5.0 V

(5) Interface circuit

a) Receiving circuit

DATA STROBE and INPUT PRIME

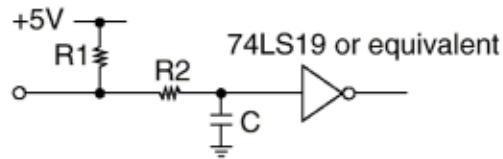

Signal name	R1	R2	C
DATA STROBE	3.3K Ω	100 Ω	560pF
INPUT PRIME	3.3K Ω	1K Ω	0.001 μ F

DATA BIT-1 to 8



(b) Sending circuit

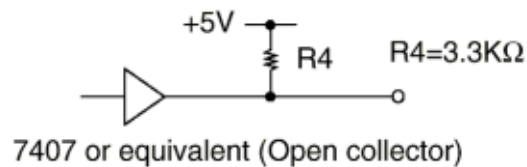

(6) Timing charts

- compatible mode

a) Data receiving timing

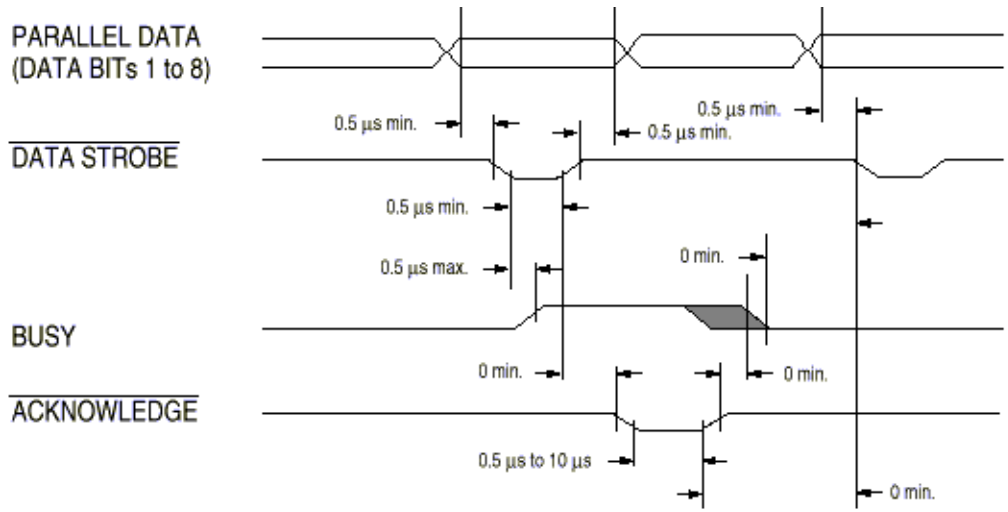

b) On-line --> off-line switching timing by ON-LINE SW

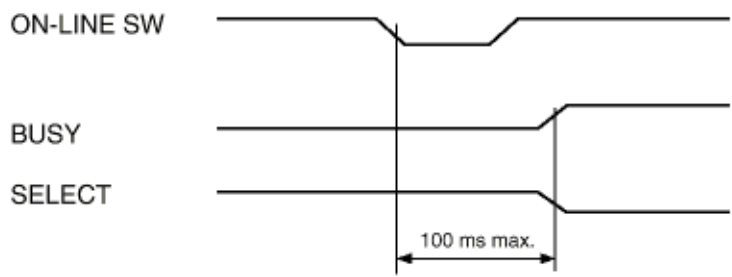

c) Off-line ---> on-line switching by ON-LINE SW

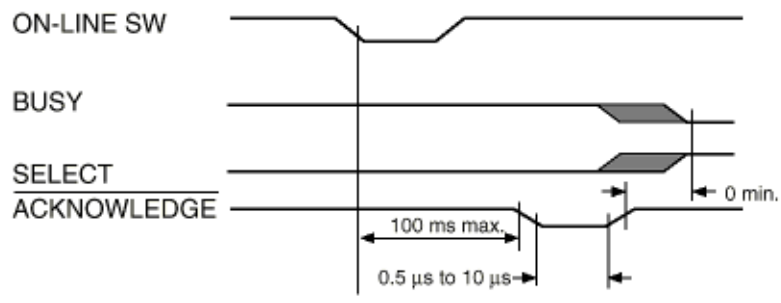

(d) INPUT PRIME timing (when set to the effective INPUT PRIME signal)

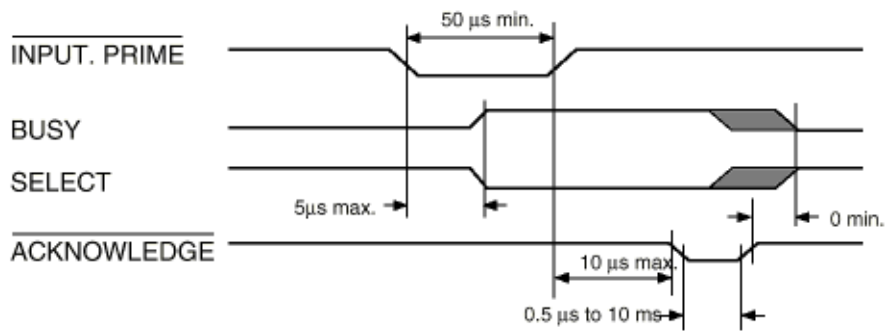

- Nibble Mode
Conforms to IEEE 1284 spec.
- ECP Mode
Conforms to IEEE 1284 spec.

Copyright 1998, Okidata, Division of OKI America, Inc. All rights reserved. See the OKIDATA Business Partner Exchange (BPX) for any updates to this material. (<http://bpx.okidata.com>)



Service Guide OKIPAGE 18/18n

Chapter B RS-232C Serial Interface

RS-232C Serial Interface

(1) Connector

- Printer side: 25 receptacle
Type: 17LE-13250-27 (D4CC) (made by DDK) or equivalent
- Cable side: 25-pin plug
Type: 17JE-23250-02 (D8C) (made by DDK)

(2) Cable

- Cable length: 6 feet (1.8 m) max. (Cable shall be shielded)

Note: Cable is not provided.

3) Interface signal

Pin No.	Signal Name	Signal Direction	Compatible	Nibble
1	Frame Ground	FG		Frame ground
2	Transmitted Data	TD	<-- PR	Transmitted data
3	Received Data	RD	--> PR	Received data
4	Request To Send	RTS	<-- PR	Stay space level
5	-			(Not connected)
6	-			(Not connected)
7	Signal Ground	SG		Signal ground
8~17	-			(Not connected)
18	+5V		<-- PR	+5V (50mA max.)
19	-			(Not connected)
20	Data Terminal Ready	DTR	<-- PR	Data terminal ready
21~25	-			(Not connected)

- Connector pin arrangement

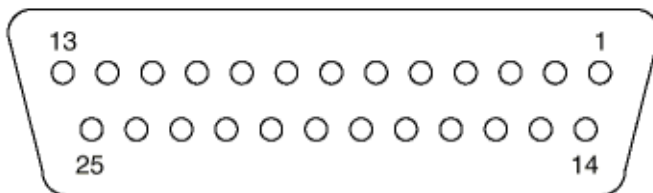

(View from the cable side)

(4) Signal level

- MARK polarity: -3V to -15V (LOGIC =1)
- SPACE polarity: +3V to +15V (LOGIC = 0)

(5) Interface circuit

a) Receiving circuit

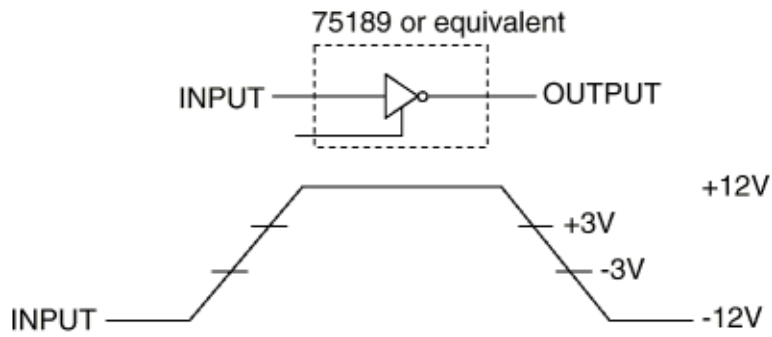

(b) Sending circuit

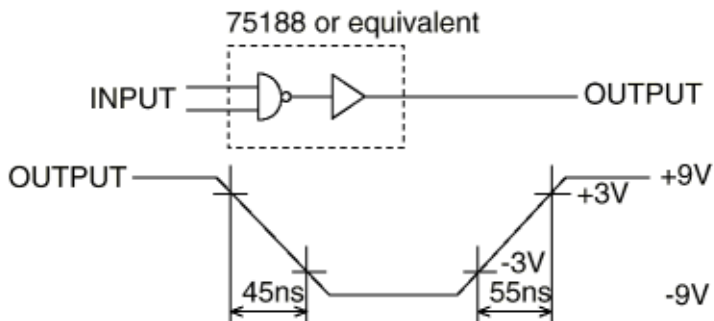

Note: The above signal level is for the case where 3KOhms x 15pF is being connected to the terminal.

(6) Communication protocol

- a) READY/BUSY protocol
- b) X-ON/X-OFF protocol



Service Guide OKIPAGE 18/18n
Chapter C Duplex Unit Maintenance (option)

1. OUTLINE

1.1 Functions

1.2 External View and Component Names

Copyright 1998, Okidata, Division of OKI America, Inc. All rights reserved. See the OKIDATA Business Partner Exchange (BPX) for any updates to this material. (<http://bpx.okidata.com>)



Service Guide OKIPAGE 18/18n Chapter C Duplex Unit Maintenance (option)

1.1 Functions

DUPLEX UNIT is a unit, which is installed on the printer unit for controlling both-sided printing from the printer unit, intended for automatically reversing papers of which one side have been already printed and re-feeding them to the unit for printing other side.

The main functions are the followings:

- Paper that can be used:

[Paper Type]

- Cut Sheet Size: A4, Letter, Executive, Legal13, Legal14
- Special Size: Paper Width: 210 to 216mm ; Paper length: 279 to 356mm

[Weight]

- 16 lbs ~ 24 lbs (64 ~ 81 g/m²)
-

Copyright 1998, Okidata, Division of OKI America, Inc. All rights reserved. See the OKIDATA Business Partner Exchange (BPX) for any updates to this material. (<http://bpx.okidata.com>)

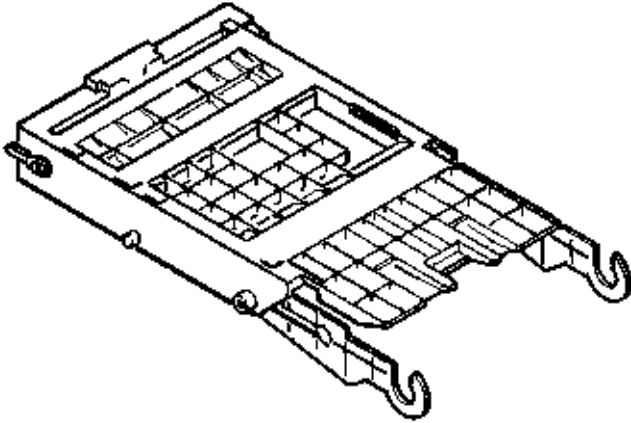
1.2 External View and Component Names

Copyright 1998, Okidata, Division of OKI America, Inc. All rights reserved. See the OKIDATA Business Partner Exchange (BPX) for any updates to this material. (<http://bpx.okidata.com>)



Service Guide OKIPAGE 18/18n
Chapter C Duplex Unit Maintenance (option)

2.0 Mechanism Description

2.1 General Mechanism

2.2 JAM Release Mechanism

2.3 Removing/Installing Duplex Unit

Copyright 1998, Okidata, Division of OKI America, Inc. All rights reserved. See the OKIDATA Business Partner Exchange (BPX) for any updates to this material. (<http://bpx.okidata.com>)

Service Guide OKIPAGE 18/18n
Chapter C Duplex Unit Maintenance (option)

2.1 General Mechanism

When the Duplex Unit receives an instruction for both-sided printing from the unit, the separator will be opened by the action of a solenoid within Duplex and the route will be shifted to the one into the Duplex after one-sided printing of papers, which are fed from the tray, are completed. At this time, as the roller (1) rotates in the direction of arrow A, a sheet is retracted in the rear of the cassette. And then, a given time later after the edge of the sheet passes through the IN SNS (DUP), the roller will reverse and the roller (1) rotates in the direction of arrow B and sending out the paper into the Duplex. After that, it passes through the roller (2) and (3), and is fed again into the unit, given a another-sided printing and ejected.

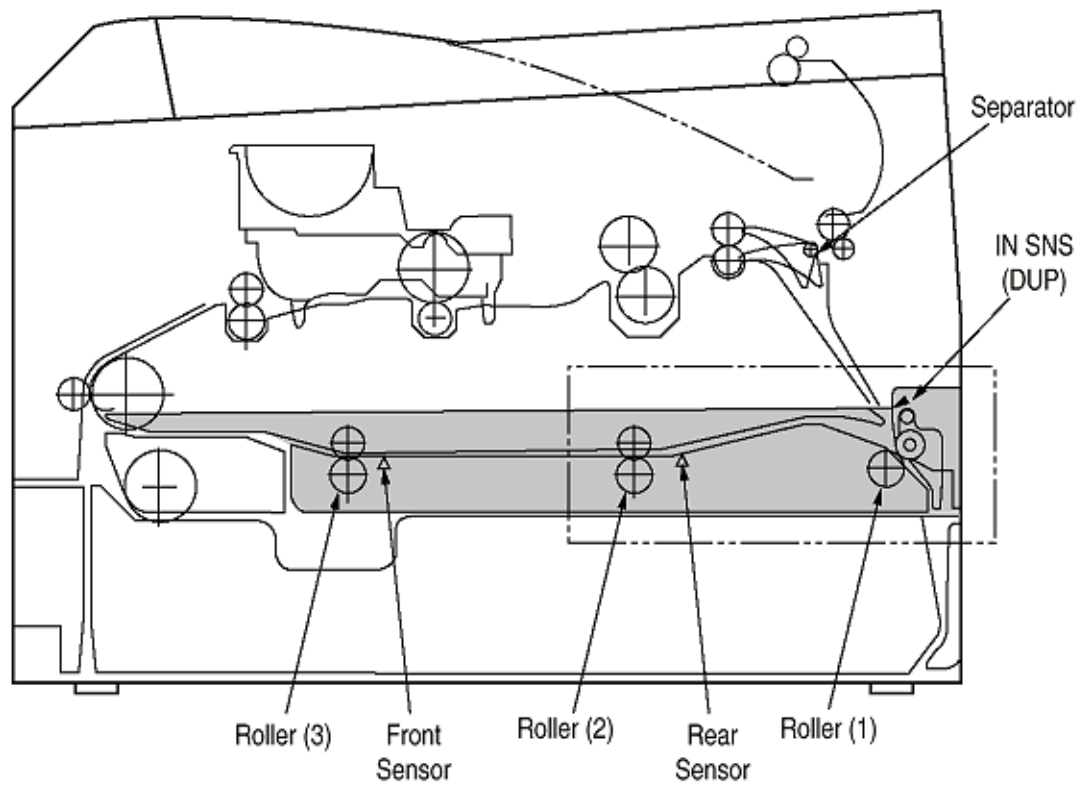

<In retracting paper>

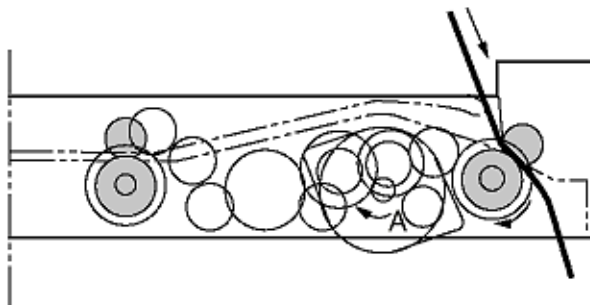

<In sending out paper>

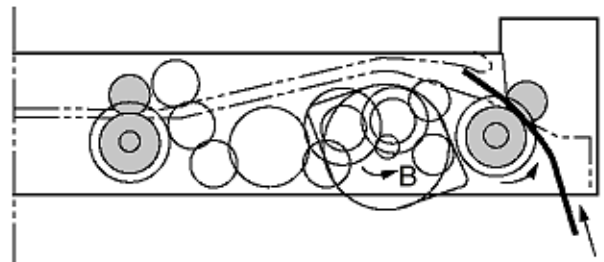

Copyright 1998, Okidata, Division of OKI America, Inc. All rights reserved. See the OKIDATA Business Partner Exchange (BPX) for any updates to this material. (<http://bpx.okidata.com>)

Service Guide OKIPAGE 18/18n
Chapter C Duplex Unit Maintenance (option)**2.2 JAM Release Mechanism**

The LEVER-Lock can be pulled outwards and the sheet route section of the Duplex opens by pulling out the cassette. This enables a jam to be released. Structurally, the LEVER-Release can be pushed up by back edge of cassette and the sheet route automatically close when the cassette is returned.

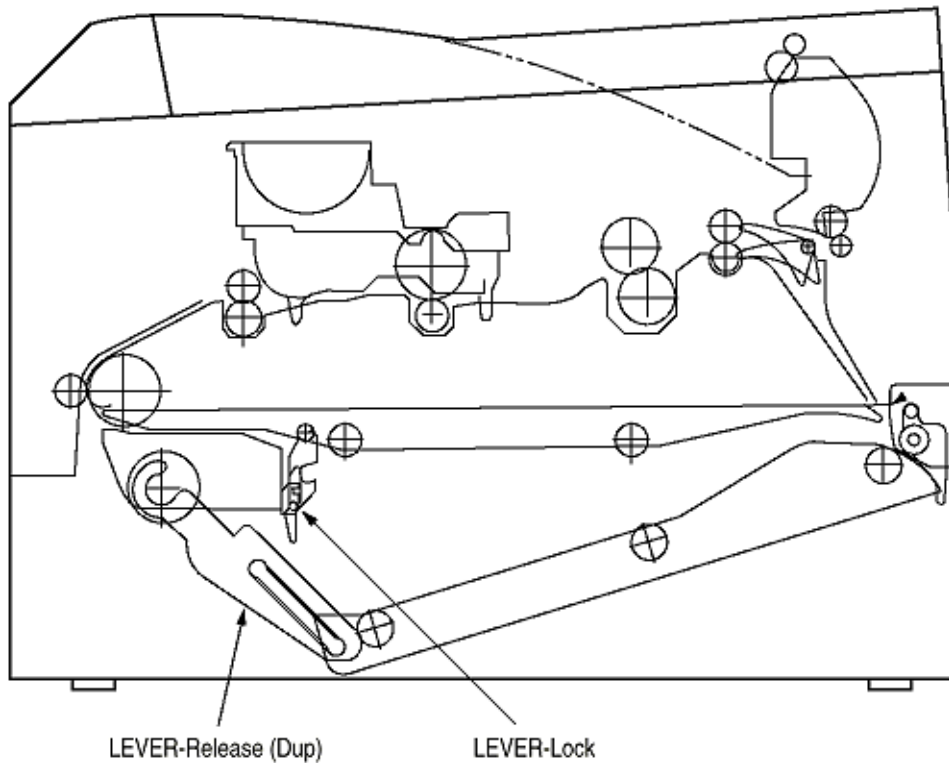

2.3 Removing/Installing Duplex Unit**Removing Duplex Unit**

- (1) Power Off and remove the Paper-Cassette from 1st tray.
- (2) Remove the Lever-Release from the boss of the Hopping Frame.

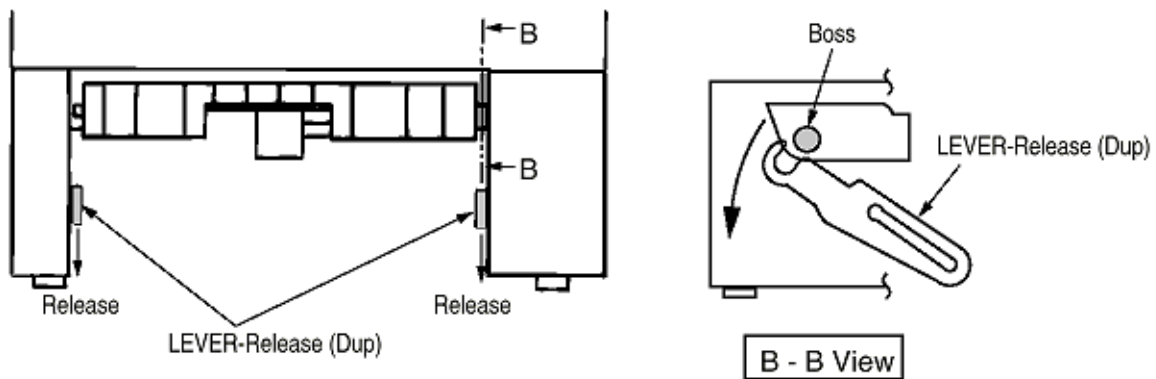

- (3) Rotate the LEVER-Lock (Dup) in the direction of the arrow to release the Lock.

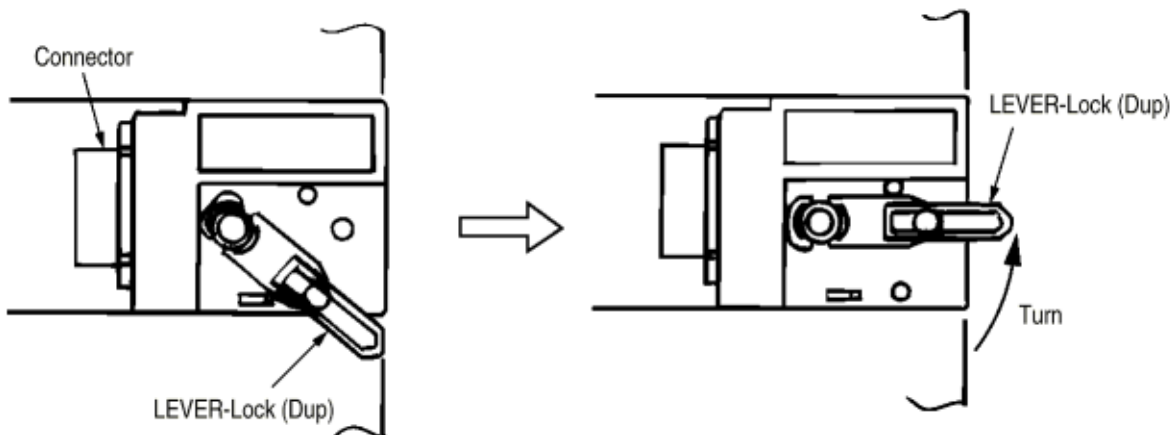

- (4) Pull the Duplex Unit out of the unit.

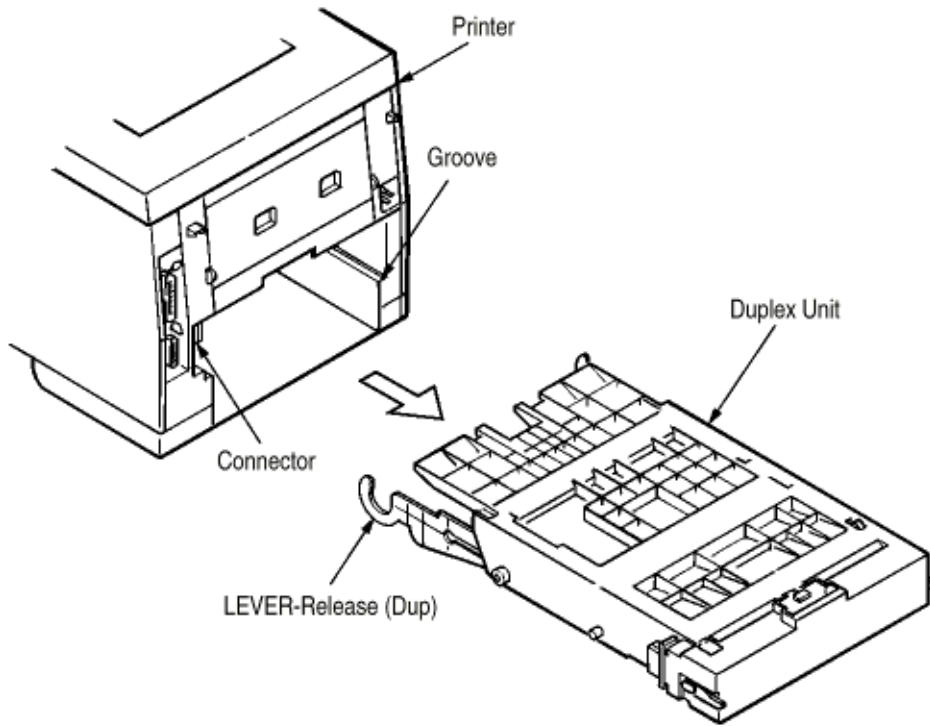

Installing Duplex Unit

(1) Hold the LEVER-Lock (Dup) in horizontal lock position. Then insert the Duplex Unit along the groove, up to accord both rear faces between printer and Duplex Unit.

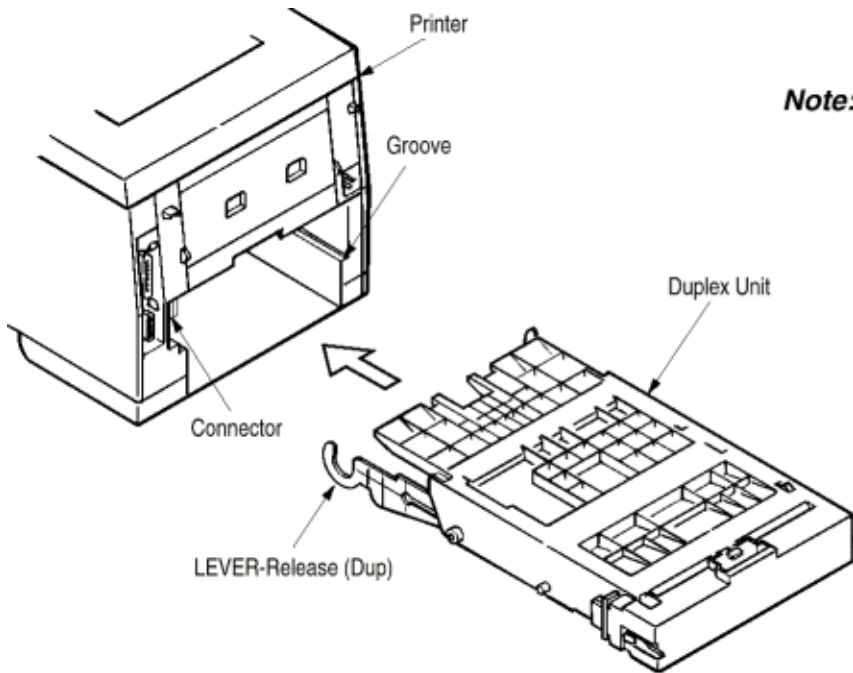

Note: Before setting it to the unit, make sure that the LEVER-Release (Dup) is locked at the angle as shown Locking point

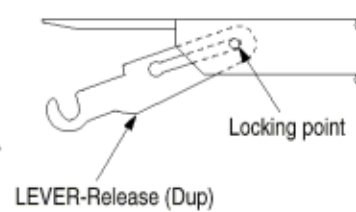

Printer and Duplex Unit will connect automatically with built-in connector.

(2) Lock the Duplex Unit to the printer by turning the LEVER-Lock (Dup) to the next locking position as below.

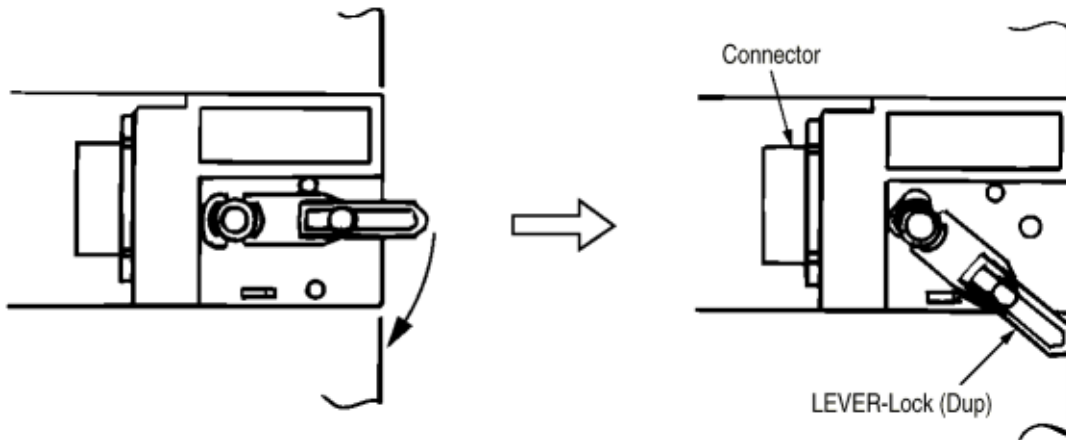

(3) From front side of printer, snap fit LEVER-Release (Dup) into the boss in Hopping Frame.

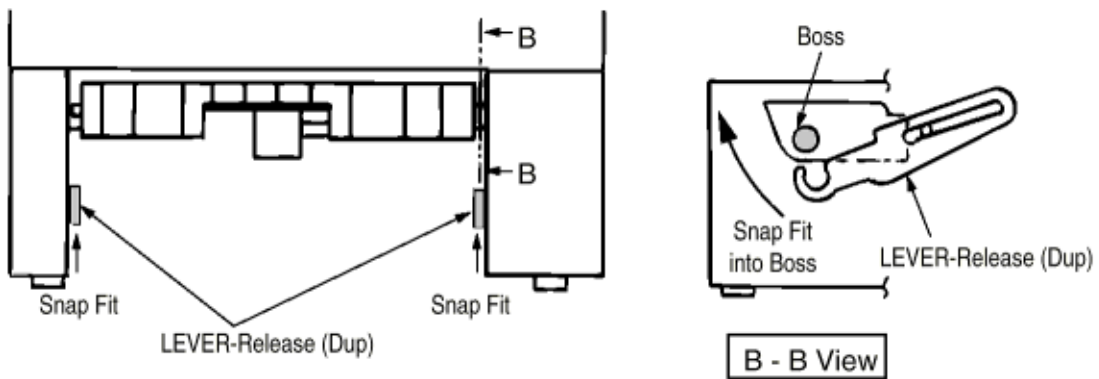

(4) After installing Duplex Unit, put back the Paper Cassette into 1st Tray.



Service Guide OKIPAGE 18/18n

Chapter C Duplex Unit Maintenance (option)

3.0 Parts Replacement

This section covers the procedures for the disassembly, reassembly and installations in the field. This section describes the disassembly procedures, and for reassembly procedures, basically proceed with the disassembly procedures in the reverse order.

3.1 Precautions Concerning Parts Replacement

3.2 Parts Layout

3.3 Parts Replacement Methods

Copyright 1998, Okidata, Division of OKI America, Inc. All rights reserved. See the OKIDATA Business Partner Exchange (BPX) for any updates to this material. (<http://bpx.okidata.com>)











Service Guide OKIPAGE 18/18n

Chapter C Duplex Unit Maintenance (option)

3.1 Precautions Concerning Parts Replacement

- (1) Parts replacements must be carried out, by first turning the printer power switch off "O" and removing the Duplex Unit from the printer.
- (2) Do not disassemble the Duplex Unit if it is operating normally.
- (3) Establish the extent of disassembly suitable for the purpose of the procedure, and do not disassemble any more than necessary.
- (4) Only specified service tools may be used.
- (5) Disassembly must be carried out according to the prescribed procedures. Parts may be damaged if such procedures are not followed.
- (6) Small parts such as screws and collars can easily be lost, therefore these parts should be temporarily fixed in the original location.
- (7) When handling printed circuit boards, do not use any glove which may generate static electricity.
- (8) Do not place the printed circuit boards directly on the equipment or floor.

Table 3-1 Service Tools

No.	Service Tools	Q'ty	Place of use	Remarks
1	 No. 1-100 Philips screwdriver	1	2~2.5 mm screws	
2	 No. 2-100 Philips screwdriver	1	3~5 mm screws	
3	 No. 3-100 screwdriver	1		
4	 No. 5-200 screwdriver	1		
5	 Digital multimeter	1		
6	 Pliers	1		
7	 Handy cleaner	1		
8	 Connector remover OKI P/N: 4PP4076-5395P1	1		



3.2 Parts Layout

This section describes the layout of the main components.

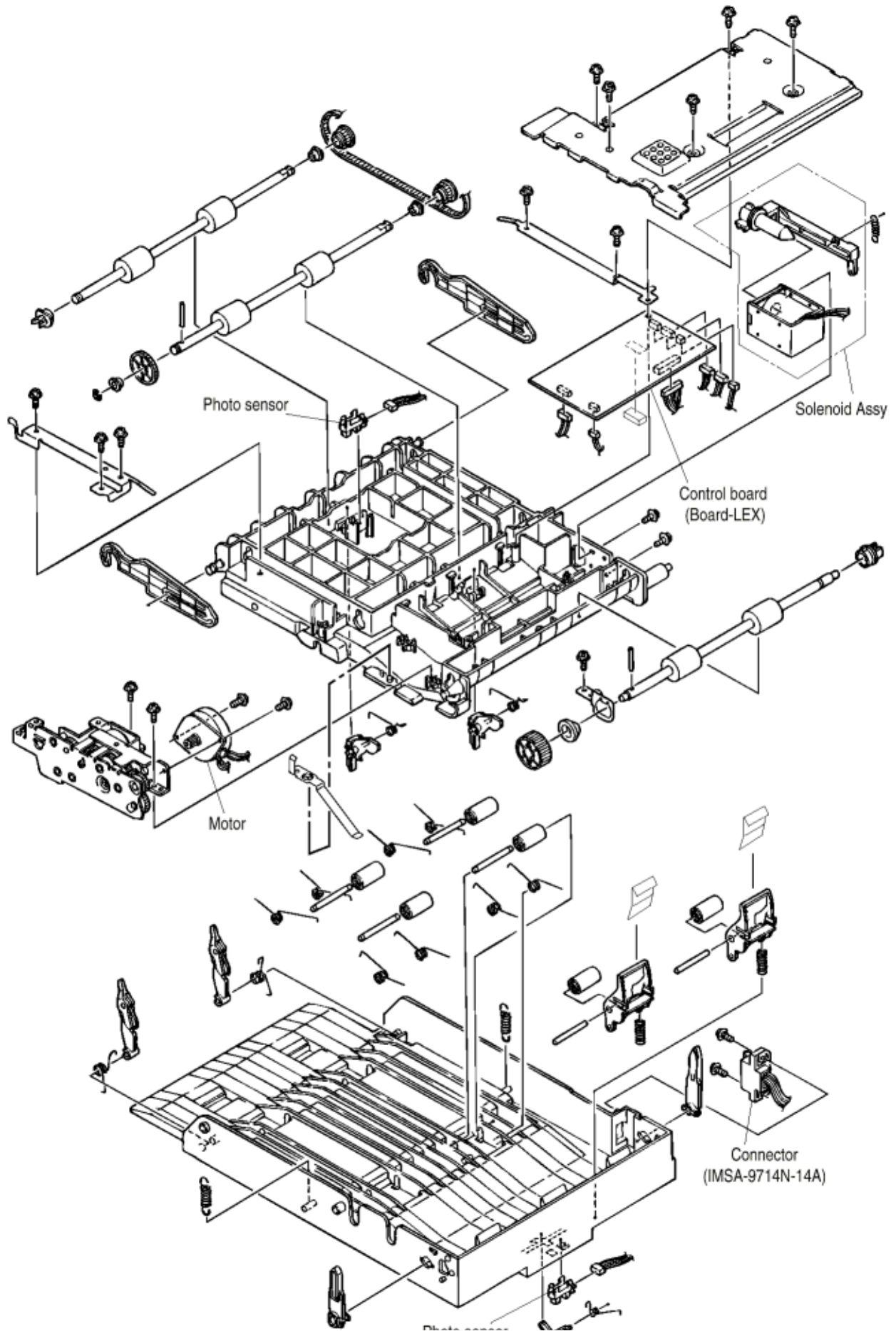

Copyright 1998, Okidata, Division of OKI America, Inc. All rights reserved. See the OKIDATA Business Partner Exchange (BPX) for any updates to this material. (<http://bpx.okidata.com>)

Service Guide OKIPAGE 18/18n
Chapter C Duplex Unit Maintenance (option)

3.3 Parts Replacement Methods

This section describes the parts replacement methods for the components listed in the disassembly order diagram below.

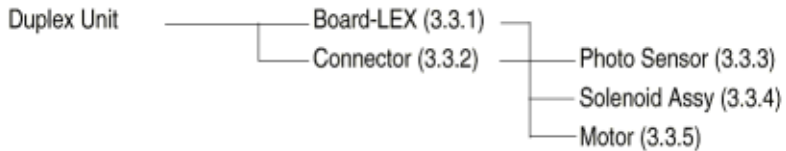
**3.3.1 Board-LEX****3.3.2 Connector (IMSA-9714N-14A)****3.3.3 Photo Sensor****3.3.4 SOLENOID Assy****3.3.5 Motor**



3.3.1 Board-LEX

- (1) Remove two LEVER-Lock (DUP) (1) by rotating them in the arrow direction.
- (2) Unscrews five screws (2) to remove the bracket (3).
- (3) Unlatch all the nails and unplug all the connectors (4) to remove the Board-LEX (5).

[Note: When installing the Board-LEX, install it, positioning earth plate over the PCB.]

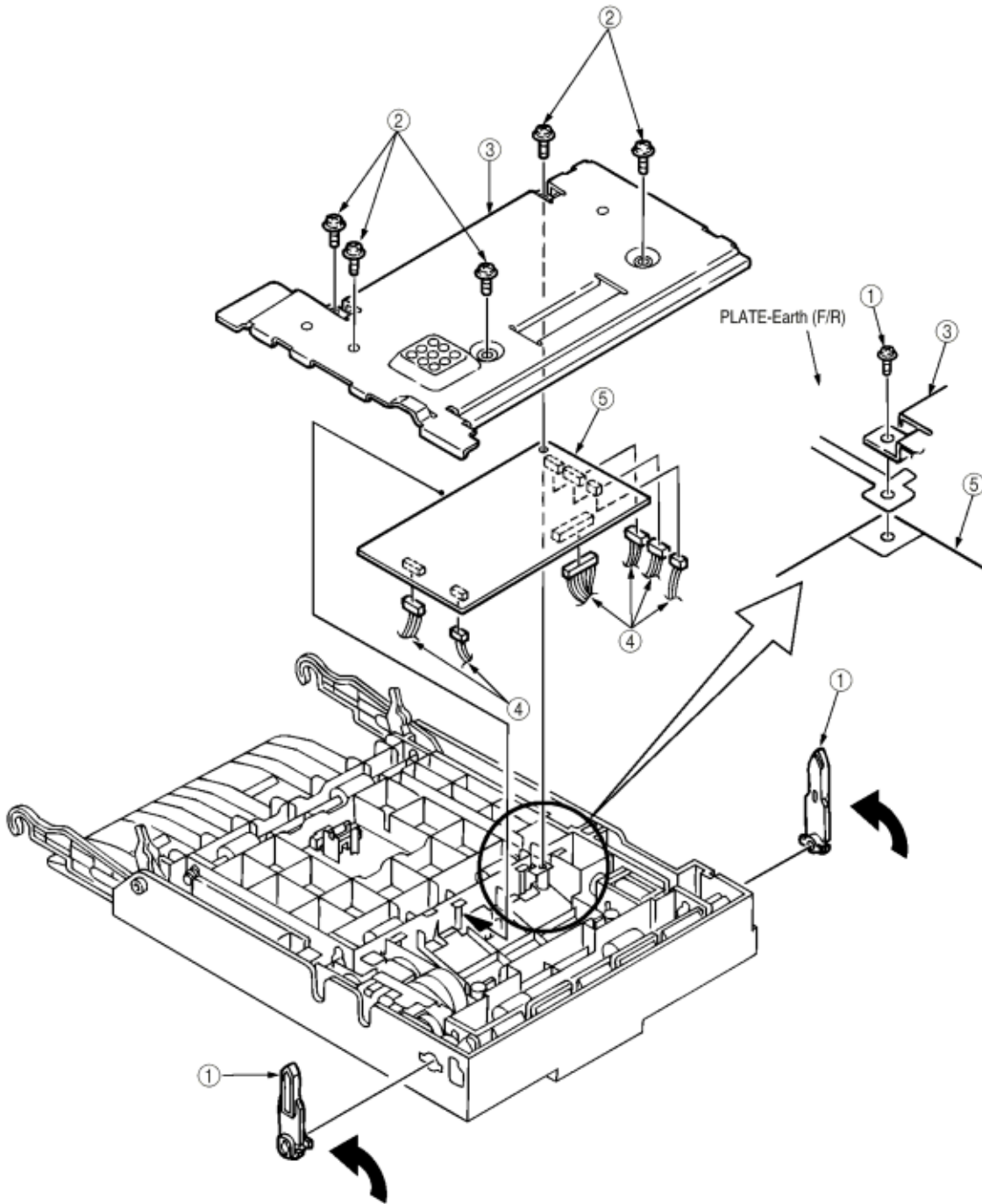

Copyright 1998, Okidata, Division of OKI America, Inc. All rights reserved. See the OKIDATA Business Partner Exchange (BPX) for any updates to this material. (<http://bpx.okidata.com>)



Service Guide OKIPAGE 18/18n
Chapter C Duplex Unit Maintenance (option)

3.3.2 Connector (IMSA-9714N-14A)

- (1) Remove two LEVER-Release (DUP) (1).
- (2) Take away two SPRING-Support (2) to remove FRAME-MAIN (DUP) (3).
(Remove the FRAME-MAIN (DUP) by lifting in up from (A) side)
- (3) Unscrew two screws (4) to unplug the Connector (IMSA-9714N-14A) (5).

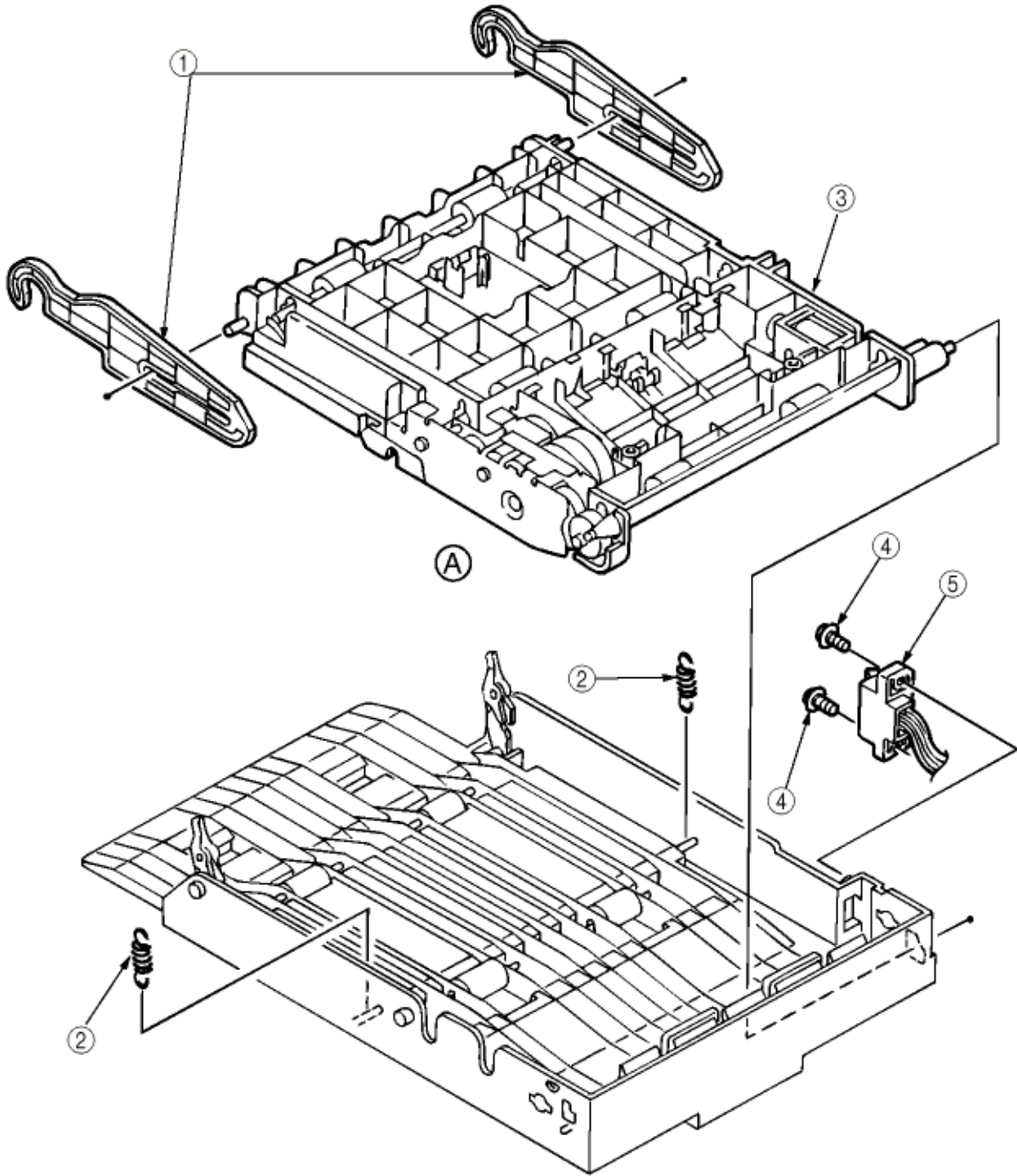



Service Guide OKIPAGE 18/18n Chapter C Duplex Unit Maintenance (option)

3.3.3 Photo Sensor

- (1) Remove the Frame-Main (DUP) (see section 3.3.2).
- (2) Release the lock to remove two SPRING-Lock (frame) (1) and two LEVER-Lock Assy (2).
- (3) Pull out four SHAFT-Pinch (3) and remove four ROLLER-Pinch (4) and eight SPRING-Pinch (u) (5).
- (4) Release the lock to remove two BRACKET-Pinch (6) , and two SPRING-Pinch (R) (9).
- (5) Release the lock to remove LEVER Sensor (D-IN) (10) and SPRING-Sensor (11).
- (6) Unplug the Connection Code-Wire (12) and remove Photo Sensor (13).

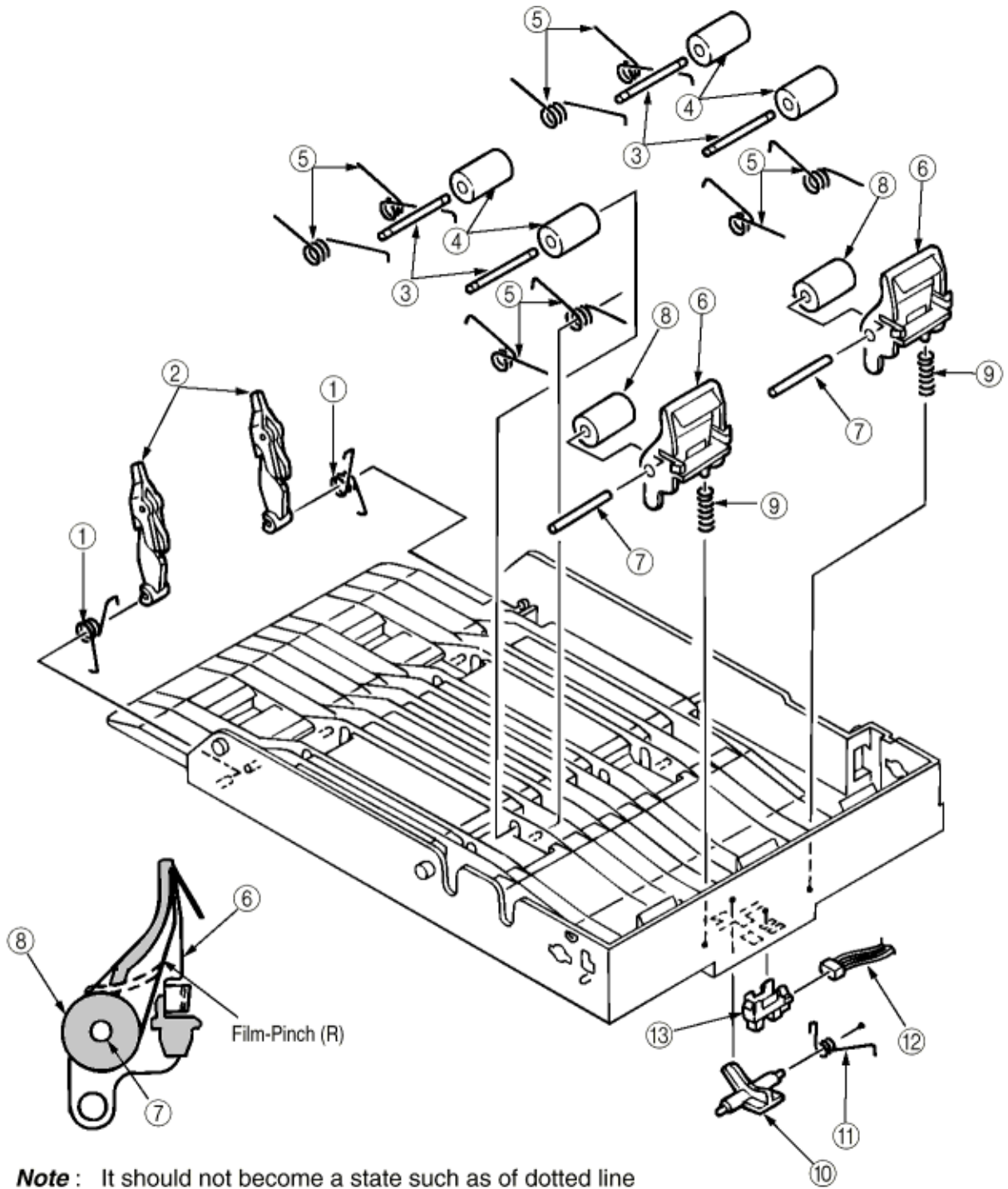

Note : It should not become a state such as of dotted line from the results of installation.



3.3.4 SOLENOID Assy

- (1) Remove the Frame-Main (DUP) (See section 3.3.2).
- (2) Release the lock to remove Two LEVER Sensor (F/R) (1) and two SPRING-Sensor (F/R) (2).
- (3) Unplug the Connection Code-Wire (3) and remove Photo Sensor (4).
- (4) Take away the SPRING-SL (5) and two screws (6) to remove SOLENOID Assy (7).

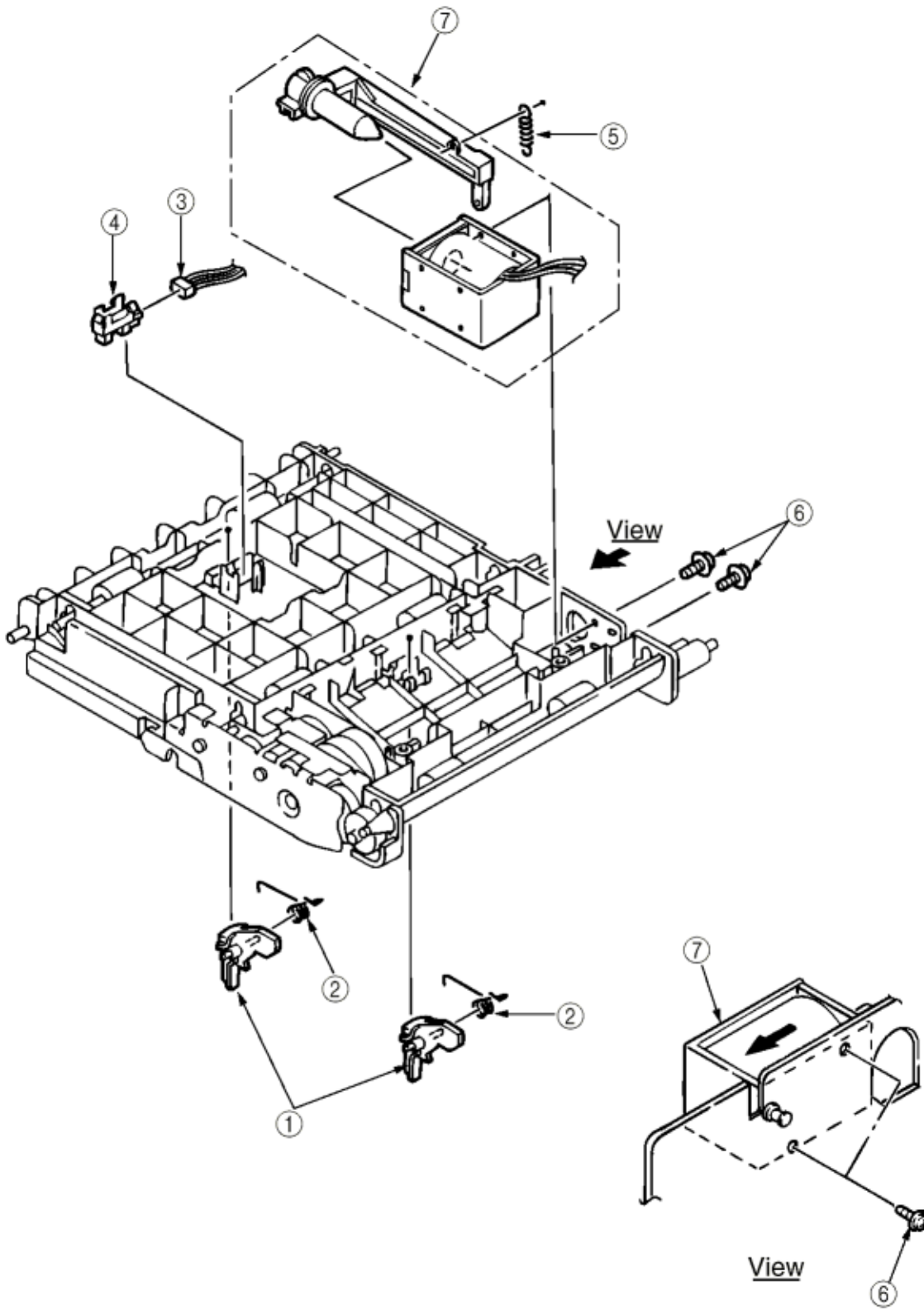

Exchange (BPX) for any updates to this material. (<http://bpx.okidata.com>)



Service Guide OKIPAGE 18/18n Chapter C Duplex Unit Maintenance (option)

3.3.5 Motor

- (1) Remove the Frame-Main (DUP) (See section 3.3.2).
 - (2) Unscrew two screws (1) to remove PLATE-Earth (F/R) (2).
 - (3) Unscrew three screws (3) to remove PLATE-Earth (F/R-2) (4).
 - (4) Disengage the latch to remove the Bearing L (5) , GEAR-Z40S8 (6) , Bearing (7) and ROLLER-Feed (RV) 8). (At this time, Knock Pin (9) can be removed simultaneously.)
 - (5) Unscrew the screw (10) to remove the PLATE-Earth (BTM) (11).
 - (6) Disengage the latch and remove two PULLEY-MX25 (12) , Mini-Pitch Belt (13) and two Bushes (14).
 - (7) Disengage the latch to remove the Bearing Feed (15) and ROLLER Feed (F) (16).
 - (8) Remove the E-Ring (17) and Bush (18).
 - (9) Unscrew two screws (19) to remove the GEAR Assy (20).
- (At this time, the GEAR-Z40S6 (21) , Knock Pin (22) and ROLLER-Feed (R) (23) can be removed.)
- (10) Unscrew two screws (24) to remove Motor (25).

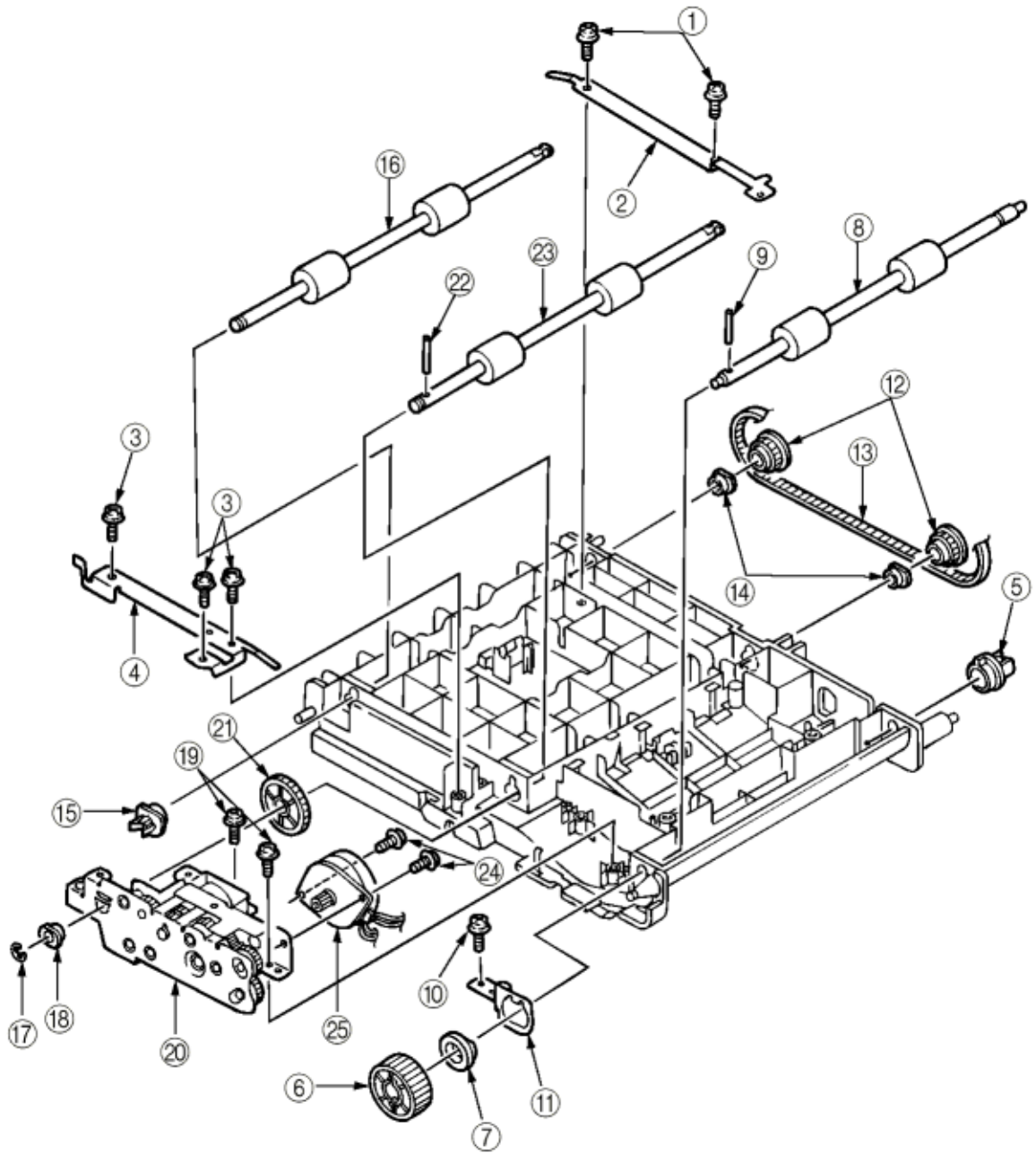

Copyright 1998, Okidata, Division of OKI America, Inc. All rights reserved. See the OKIDATA Business Partner Exchange (BPX) for any updates to this material. (<http://bpx.okidata.com>)



Service Guide OKIPAGE 18/18n
Chapter C Duplex Unit Maintenance (option)

4.0 Troubleshooting

4.1 Precautions Prior to the Troubleshooting

4.2 Preparations for the Troubleshooting

4.3 Troubleshooting Method

Copyright 1998, Okidata, Division of OKI America, Inc. All rights reserved. See the OKIDATA Business Partner Exchange (BPX) for any updates to this material. (<http://bpx.okidata.com>)



Service Guide OKIPAGE 18/18n
Chapter C Duplex Unit Maintenance (option)

4.1 Precautions Prior to the Troubleshooting

- (1) Go through the basic checking items provided in the Operator Guide.
- (2) Obtain detailed information concerning the problem from the user.
- (3) Go through the checking in the conditions similar to that in which the problem occurred.

Copyright 1998, Okidata, Division of OKI America, Inc. All rights reserved. See the OKIDATA Business Partner Exchange (BPX) for any updates to this material. (<http://bpx.okidata.com>)



Service Guide OKIPAGE 18/18n
Chapter C Duplex Unit Maintenance (option)

4.2 Preparations for the Troubleshooting

(1) Display on the Operator panel

The status of the problem is displayed on the LCD (Liquid Crystal Display) on the Operator panel. Go through the appropriate troubleshooting procedures according to the messages displayed on the LCD.

Copyright 1998, Okidata, Division of OKI America, Inc. All rights reserved. See the OKIDATA Business Partner Exchange (BPX) for any updates to this material. (<http://bpx.okidata.com>)



Service Guide OKIPAGE 18/18n

Chapter C Duplex Unit Maintenance (option)

4.3 Troubleshooting Method

When a problem occurs, go through the troubleshooting according to the following procedure.

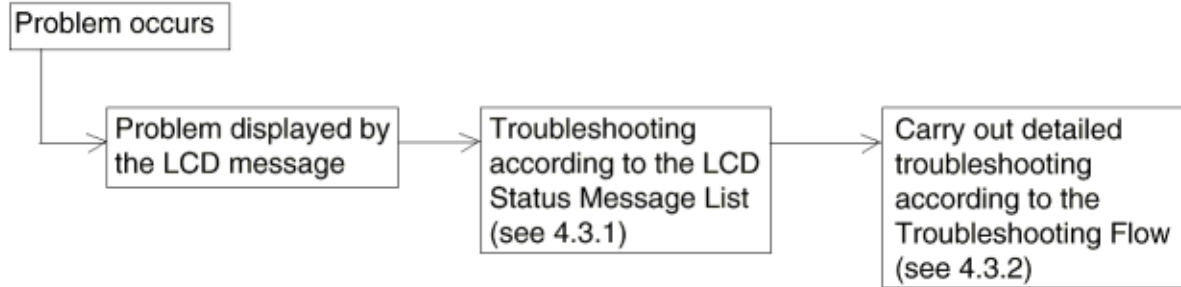

4.3.1 LCD Status Message List

4.3.2 Troubleshooting Flow



Service Guide OKIPAGE 18/18n

Chapter C Duplex Unit Maintenance (option)

4.3.1 LCD Status Message List

The listing of the statuses and problems displayed in the form of messages on the LCD is provided in Table 4-1.

Classification	LCD Status Message	Description	Recover Method
Jam Error	DUPLEX INPUT JAM REMOVE THE PAPER	Informs that a jam occurs in retracting papers into the reverse roller within the duplex Unit.	Remove all the papers from the inside of printer unit and Duplex unit and close the cover.
Jam Error	DUPLEX FEED JAM1 REMOVE THE PAPER	Informs that a jam occurs in retracting papers into the reverse roller within the Duplex Unit.	Remove all the paper from the inside of printer unit and Duplex unit and close the cover.
Jam Error	DUPLEX FEED JAM2 REMOVE THE PAPER	Informs that a jam occurs in reversing papers in the reverse roller within the Duplex Unit.	Remove all the papers from the inside of printer unit and Duplex unit and close the cover.
Jam Error	DUPLEX FEED JAM3 REMOVE THE PAPER	Informs that a jam occurs in impinge-feeding papers within the Duplex Unit.	Remove all the papers from the inside of printer unit and Duplex unit and close the cover.
Jam Error	DUPLEX OPEN JAM REMOVE THE PAPER	Informs that the 1st tray is pulled out in paper-remaining state when feeding papers within the Duplex.	Remove all papers from the inside of printer unit and Duplex unit and close the cover.
Interface Timeout	ERROR 83	Informs that an I/F time-out occurs between the printer and Duplex.	- Verify connection of LEX-PCB and square-shaped connector. Replace the square-shaped connector if necessary. - Replace LEX-PCB.



4.3.2 Troubleshooting Flow

- (JAM error)

Duplex INPUT JAM

Duplex INPUT JAM

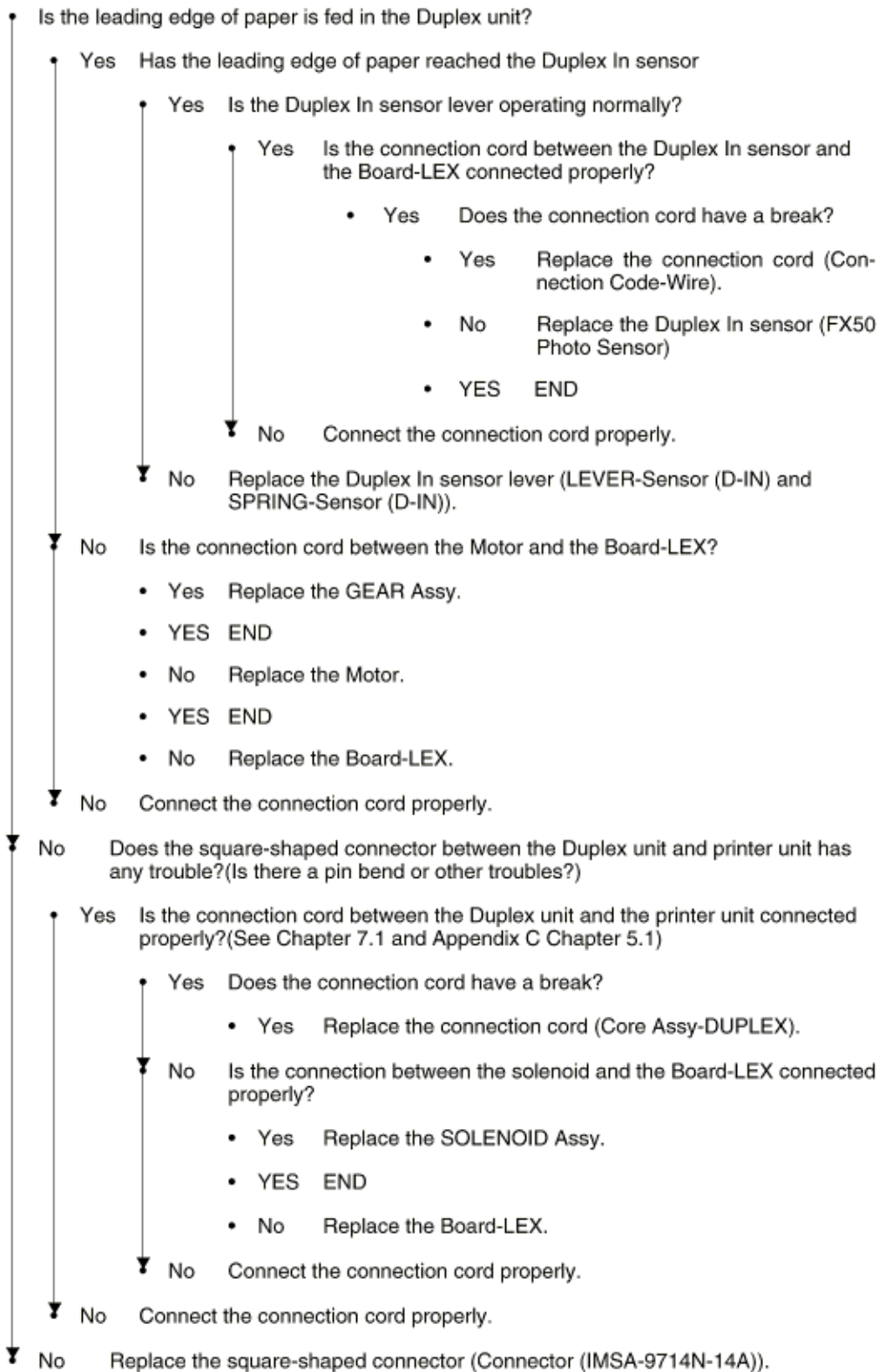

Duplex FEED JAM1

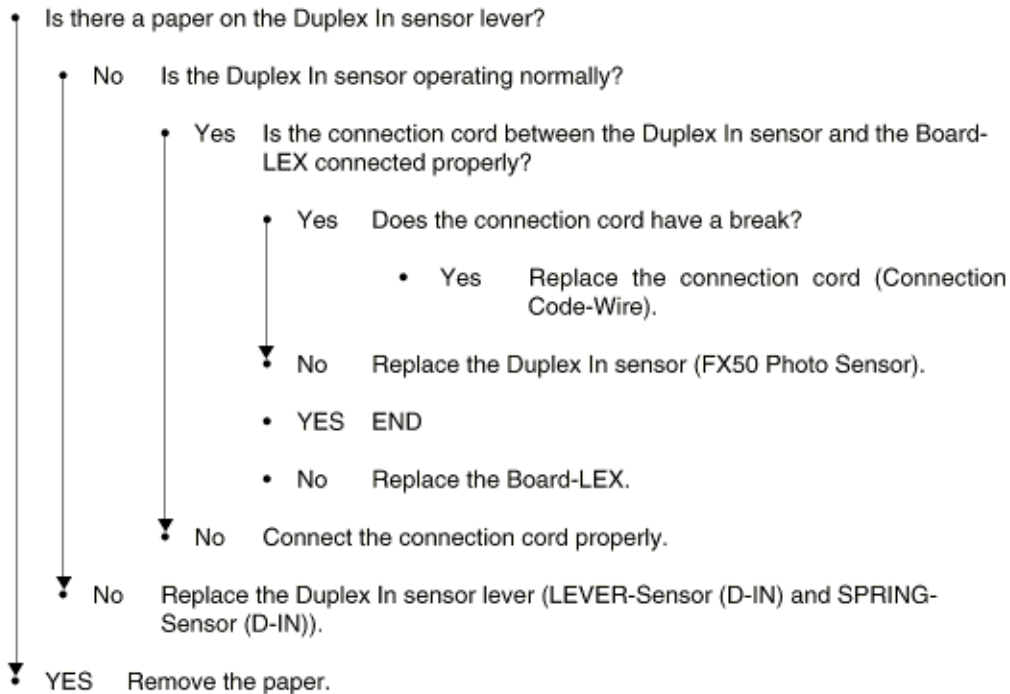

Duplex FEED JAM2

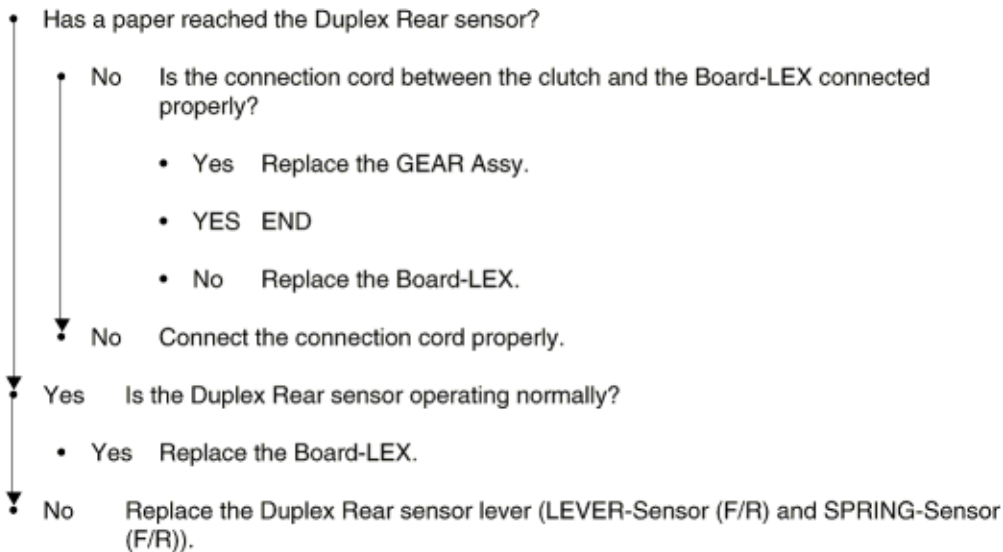

Duplex FEED JAM3

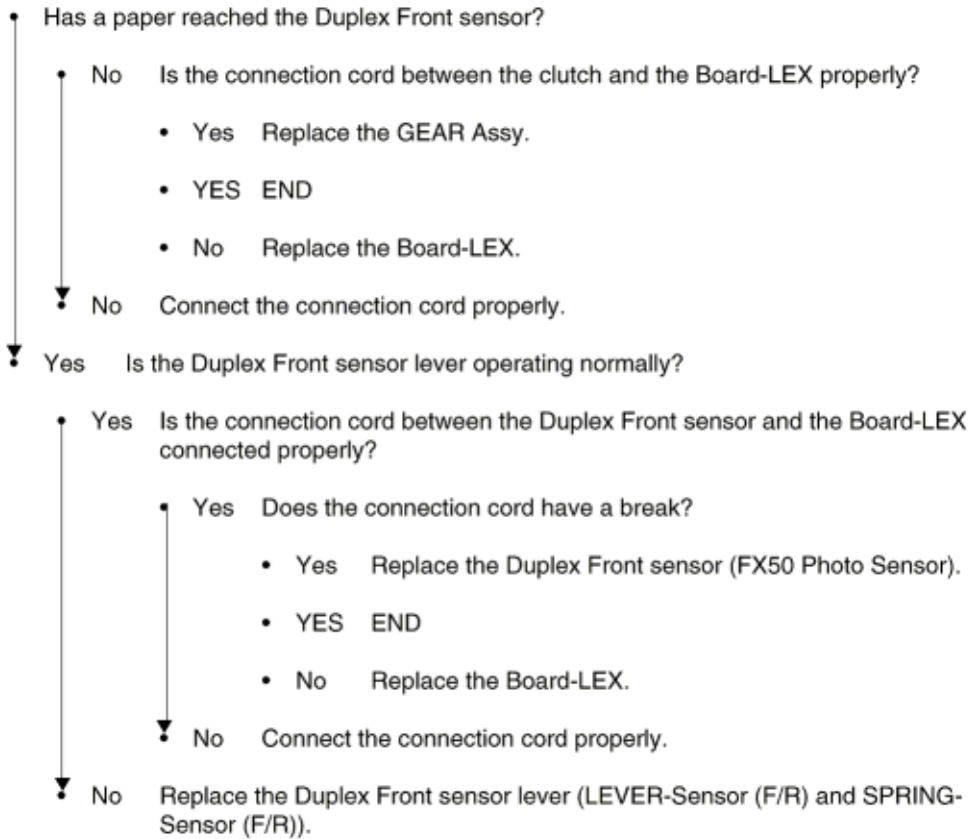



Service Guide OKIPAGE 18/18n
Chapter C Duplex Unit Maintenance (option)

5.0 Connection Diagram

5.1 Interconnection Diagram

5.2 PCB Layout

Copyright 1998, Okidata, Division of OKI America, Inc. All rights reserved. See the OKIDATA Business Partner Exchange (BPX) for any updates to this material. (<http://bpx.okidata.com>)



5.1 Interconnection Diagram

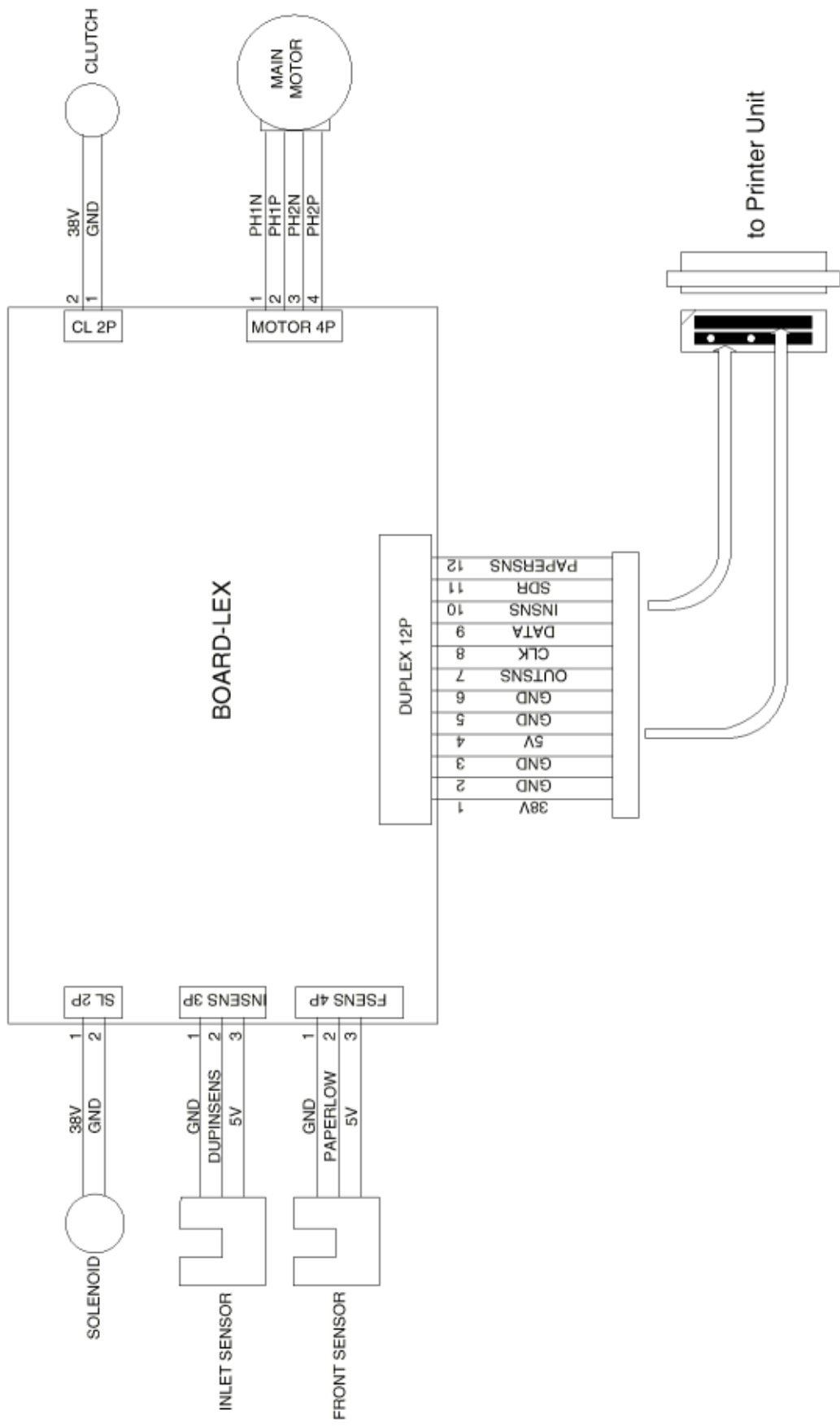

Copyright 1998, Okidata, Division of OKI America, Inc. All rights reserved. See the OKIDATA Business Partner Exchange (BPX) for any updates to this material. (<http://bpx.okidata.com>)

Service Guide OKIPAGE 18/18n Chapter C Duplex Unit Maintenance (option)

5.2 PCB Layout

PCB-LEX

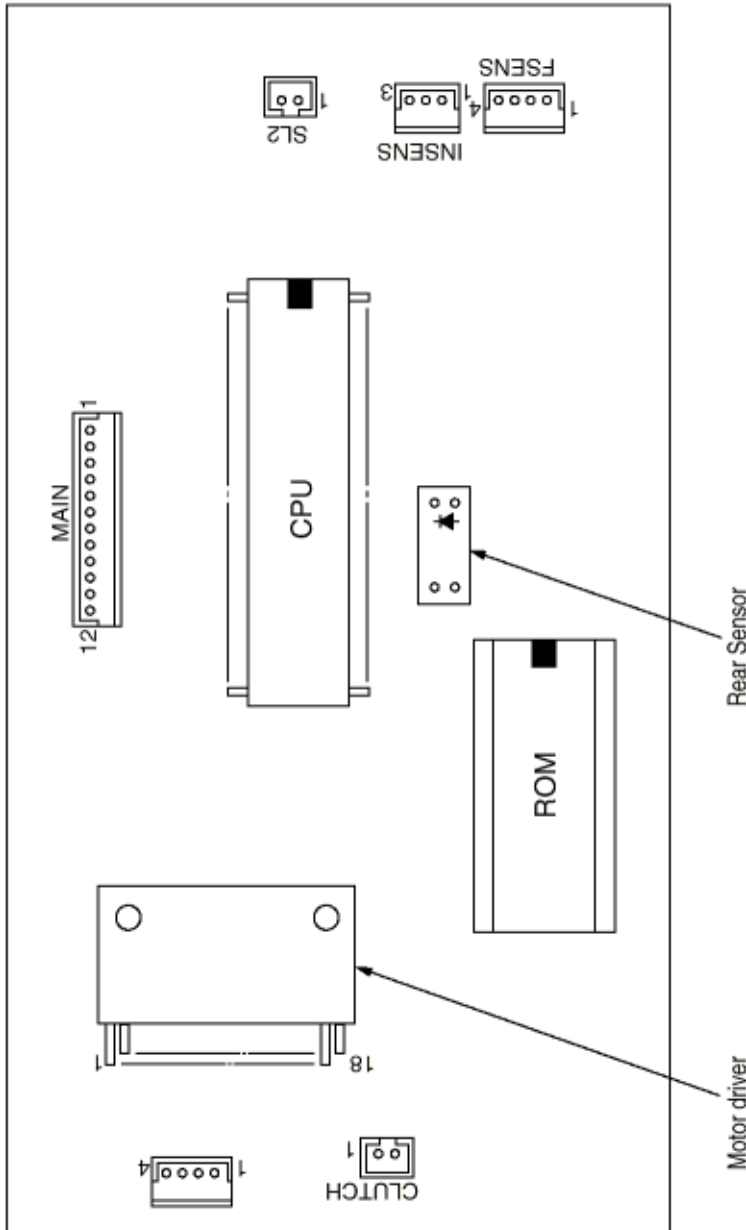



Service Guide OKIPAGE 18/18n
Chapter C Duplex Unit Maintenance (option)

6.0 Parts List

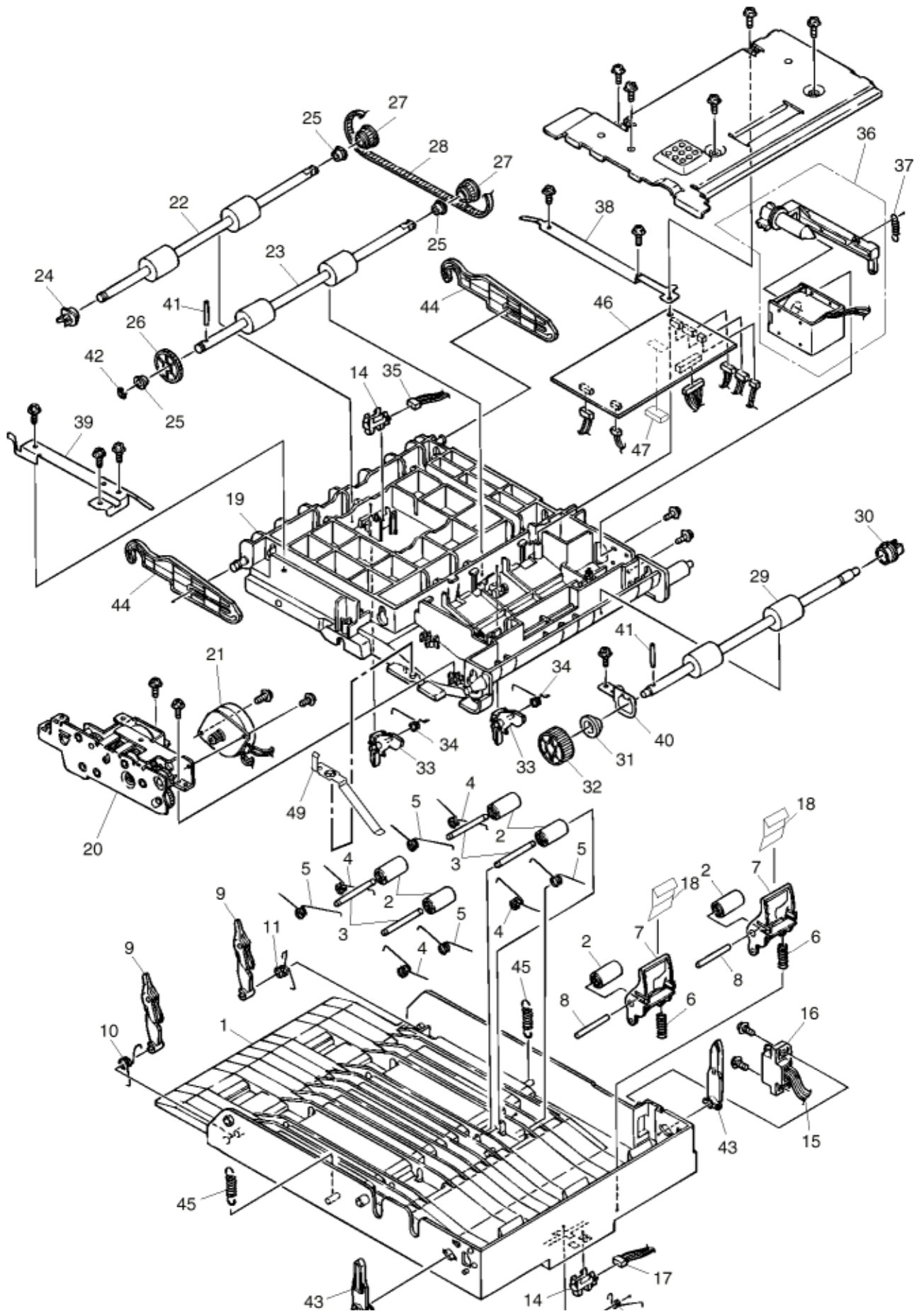

Copyright 1998, Okidata, Division of OKI America, Inc. All rights reserved. See the OKIDATA Business Partner Exchange (BPX) for any updates to this material. (<http://bpx.okidata.com>)



Service Guide OKIPAGE 18/18n

Chapter C Duplex Unit Maintenance (option)

Table 6-1 Duplex Unit

No.	Part No.	Name	Qty	Recommended Qty			Remarks
				50	100	1000	
1	40658401	COVER - Upper (DUP) (Affix)	1	1	3	6	#
2	40339401	ROLLER - Pinch	6	6	18	36	#
3	40382201	SHAFT - Pinch	4	4	12	24	#
4	40393201	SPRING - Pinch (U)	4	4	12	24	#
5	40393202	SPRING - Pinch (U)	2	2	6	12	#
6	40393301	SPRING - Pinch (R)	2	2	6	12	#
7	40457701	BRACKET - Pinch (R)	2	2	6	12	#
8	40457801	SHAFT - Pinch (R)	2	2	6	12	#
9	40443801	LEVER - Lock Assy	2	2	6	12	#
10	40541501	SPRING - Lock (frame)	1	1	3	6	#
11	40541502	SPRING - Lock (frame)	1	1	3	6	#
12	40338701	LEVER - Sensor (D-IN)	1	1	3	6	#
13	40393601	SPRING - Sensor (D-IN)	1	1	3	6	#
14	50410001	FX50 Photo Sensor	2	2	6	12	
15	40598001	Core Assy - DUPLEX	1	1	3	6	#
16	56731640	Connector (IMSA-9714N-14A)	1	1	3	6	#
17	40375201	Connection Code - Wire	1	1	3	6	# To IN Sensor
18	40461601	FILM Pinch (R)	2	2	6	12	#
19	40297201	FRAME - Main (DUP)	1	1	3	6	#
20	40597501	GEAR Assy	1	1	3	6	#
21	40921801	Motor	1	1	3	6	
22	40381801	ROLLER - Feed (F)	1	1	3	6	#
23	40381901	ROLLER - Feed (R)	1	1	3	6	#
24	51609401	Bearing - Feed	1	1	3	6	
25	51607301	Bush	3	3	9	18	
26	40339901	GEAR - Z40S6	1	1	3	6	#
27	40340301	PULLEY - MXL25	2	2	6	12	#
28	40448101	Mini-Pitch Belt	1	1	3	6	#
29	40382001	ROLLER - Feed (RV)	1	1	3	6	#
30	51608101	Bearing L	1	1	3	6	
31	51609501	FX30 Bearing	1	1	3	6	
32	40339801	GEAR - Z48S8	1	1	3	6	#
33	40338901	LEVER - Sensor (F/R)	2	2	6	12	#
34	40386501	SPRING - Sensor (F/R)	2	2	6	12	#
35	40375301	Connection Code - Wire	1	1	3	6	# To Front Sensor
36	40483401	SOLENOID Assy	1	1	3	6	#
37	40395501	SPRING - SL	1	1	3	6	#
38	40382601	PLATE - Earth (F/R)	1	1	3	6	#
39	40322901	PLATE - Earth (F/R-2)	1	1	3	6	#
40	40382801	PLATE - Earth (BTM)	1	1	3	6	#
41	50608201	Knock Pin	2	2	6	12	#
42	50709301	E Ring	1	1	3	6	#
43	40339101	LEVER - Lock (DUP)	2	2	6	12	# Color: Black
44	40338601	LEVER - Release (DUP)	2	2	6	12	#
45	40393701	SPRING - Support	2	2	6	12	#
46	40495802	Board - LEX	1	2	5	10	# W/O ROM
47	40521501	Program ROM (IC1)	1	2	5	10	#
48	40318201	COVER - Bottom (DUP)	1	1	3	6	#
49	40382701	PLATE - Earth (MTR)	1	1	3	6	#

Copyright 1998, Okidata, Division of OKI America, Inc. All rights reserved. See the OKIDATA Business Partner Exchange (BPX) for any updates to this material. (<http://bpx.okidata.com>)



Service Guide OKIPAGE 18/18n
Chapter D Second / Third Paper Feeder Maint (option)

1.0 Outline

1.1 Functions

1.2 Appearance and Parts Name

Copyright 1998, Okidata, Division of OKI America, Inc. All rights reserved. See the OKIDATA Business Partner Exchange (BPX) for any updates to this material. (<http://bpx.okidata.com>)



Service Guide OKIPAGE 18/18n

Chapter D Second / Third Paper Feeder Maint (option)

1.1 Functions

This high capacity second/ third paper feeder, which is located under the printer, rotates the hopping motor according to the signal from the printer to supply papers to the printer automatically.

The main functions are as followings:

- Applicable media:

[Paper Type]

- Cut Sheet Size: A4, A5, B5, Letter, Executive, Legal13, Legal14
- Special Size: Paper Width: 148 to 216mm; Paper length: 210 to 356mm

[Weight]

- 60 ~ 105 g/m²
 - Paper loading capacity: 75 g/m² paper 530 sheets
-

Copyright 1998, Okidata, Division of OKI America, Inc. All rights reserved. See the OKIDATA Business Partner Exchange (BPX) for any updates to this material. (<http://bpx.okidata.com>)

Service Guide OKIPAGE 18/18n Chapter D Second / Third Paper Feeder Maint (option)

Appearance and Parts Name

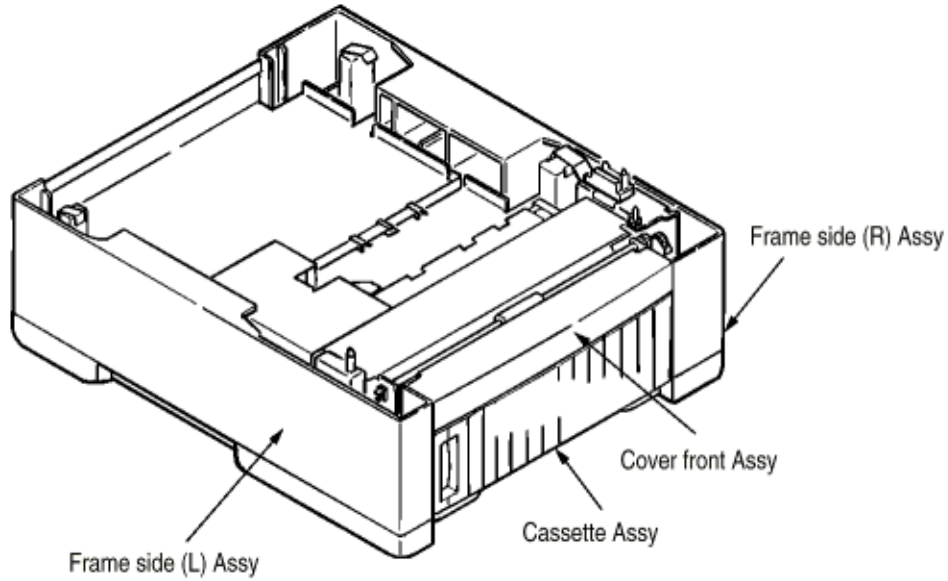

Copyright 1998, Okidata, Division of OKI America, Inc. All rights reserved. See the OKIDATA Business Partner Exchange (BPX) for any updates to this material. (<http://bpx.okidata.com>)



Service Guide OKIPAGE 18/18n
Chapter D Second / Third Paper Feeder Maint (option)

2.0 Description of operation

2.1 Driving Mechanism

2.2 Hopper Mechanism

Copyright 1998, Okidata, Division of OKI America, Inc. All rights reserved. See the OKIDATA Business Partner Exchange (BPX) for any updates to this material. (<http://bpx.okidata.com>)

Service Guide OKIPAGE 18/18n

Chapter D Second / Third Paper Feeder Maint (option)

2.1 Driving Mechanism

The high-capacity second/ third paper feeder only a top paper which is set in the cassette by a signal from the printer.

(1) Second paper feeder as an example is shown. First of all, the hopping motor rotates in the direction of arrow A. Roller C rotates by way of idle gear on the same shaft on which the hopping gear is placed. At the same time, the planetary gear D shifts in the direction of arrow E and a sub roller gear and a sub roller on the same shaft rotate. Roller C and sub roller make a paper hop. Also, the planetary gear G shifts in the direction of arrow H and Roller K rotates, and when the length of sheet is legal 13 inch or more, a hopping paper will be impinged to the regist roller within the printer. When the length of paper is A4 or less, hopping papers will be carried until the defined amount.

(2) When the length of paper is A4 or less, the hopping roller rotates in the direction of arrow B next. At this time, the planetary gear G shifts in the direction of arrow I to rotate Roller K and impinge the papers, which are carried to the defined amount, to the regist roller within the printer. During the hopping roller is rotating, Roller C is racing because it includes one-way bearing. At the same time, planetary gear D shifts in the direction of arrow F and the sub roller gear and another sub roller on the same shaft won't rotate.

(3) In the third paper feeder, when the length of paper is legal 13 inch or more, and if the rotating direction is arrow A', papers will be carried to the defined amount without being impinged to the regist roller, and then the rotating direction of the hopping roller will be changed to arrow B'. When the rotating direction of the hopping roller A' arrow direction, the motion is same as (1). When B' arrow direction, the motion will be same as (2) until Roller K' begin to rotate. The planetary gear M' will shift in the direction of arrow L by way of the gear O' which begin to rotate at the same time when the roller K' does. And gear N rotates, resulting in rotating the gear J and roller K on the same shaft, and impingeing papers to the regist roller within the printer.

At this time, as the gear O and gear P engaged by the planetary gear G on the same shaft, on which the gear J and roller K are placed, includes an one-way clutch gear, the planetary gear G won't rotate.

Impinged papers are, afterwards, fed by the control of printer's inside.

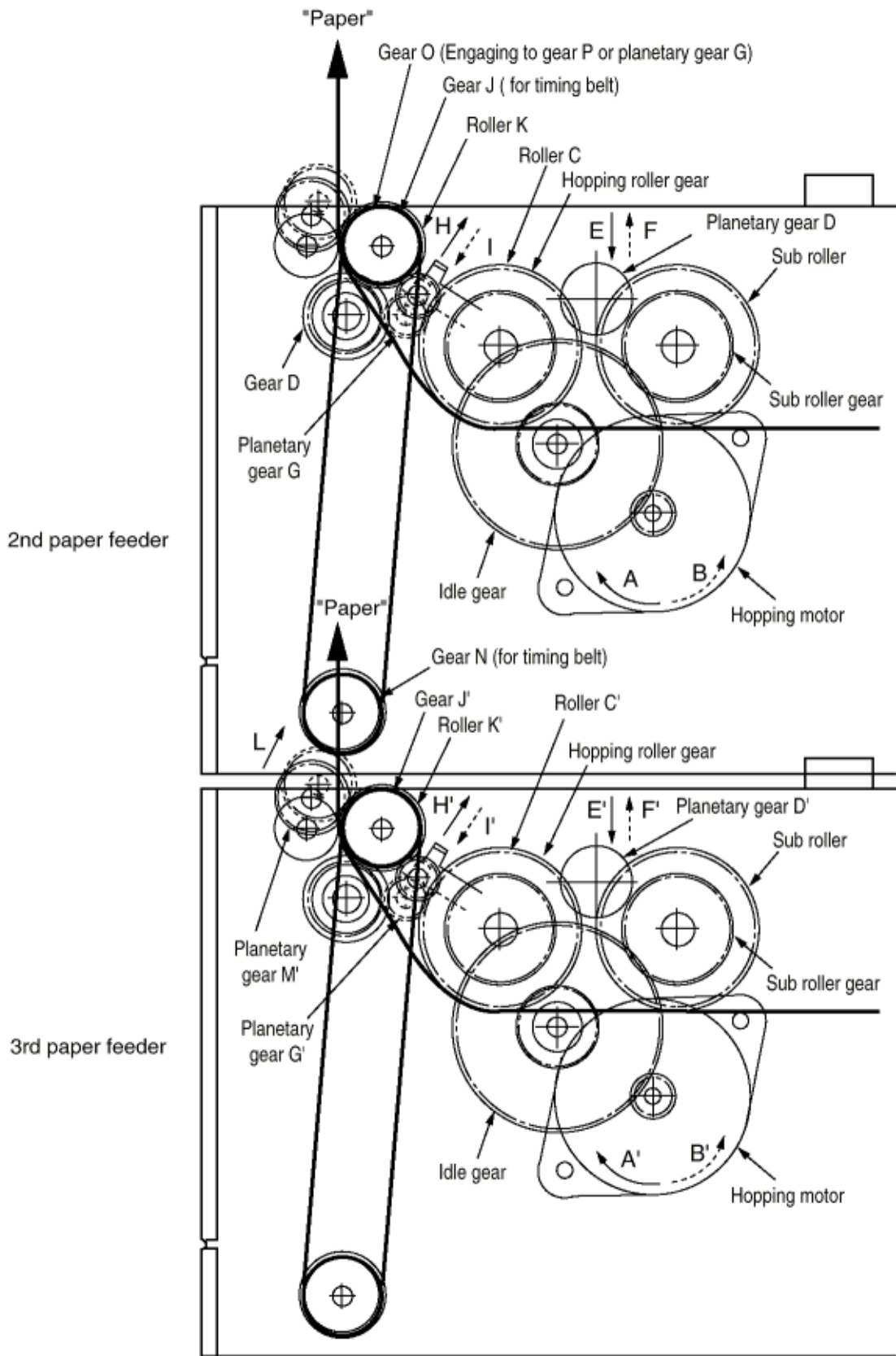

Copyright 1998, Okidata, Division of OKI America, Inc. All rights reserved. See the OKIDATA Business Partner Exchange (BPX) for any updates to this material. (<http://bpx.okidata.com>)

Service Guide OKIPAGE 18/18n

Chapter D Second / Third Paper Feeder Maint (option)

2.2 Hopper Mechanism

The hopper is a motion where papers are automatically sent into the printer one by one. When papers are set to the cassette, the feeding motion is activated by the hopping motor to send only a top paper which is caught on the brake shoe.

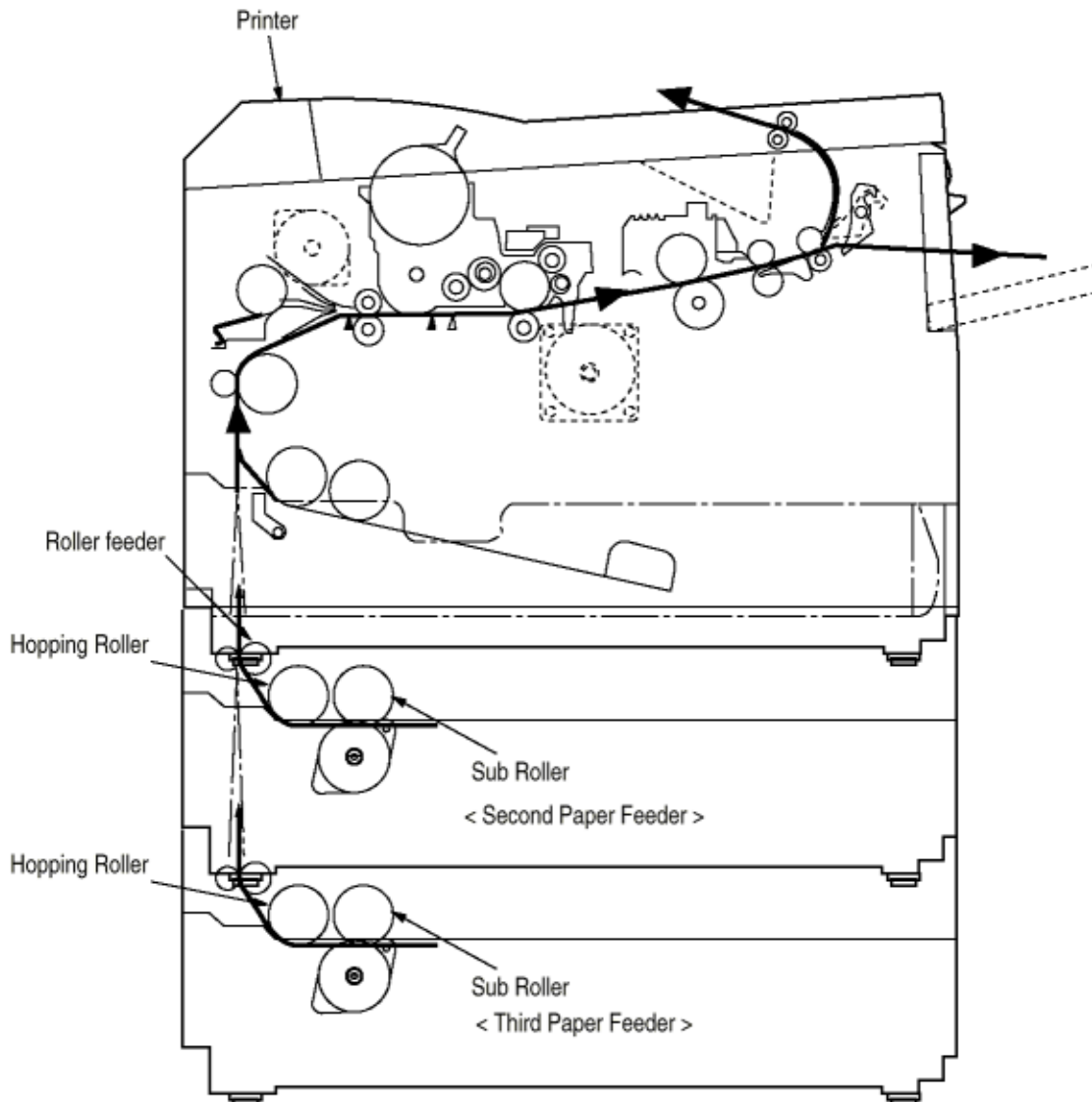



Service Guide OKIPAGE 18/18n
Chapter D Second / Third Paper Feeder Maint (option)

3.0 Parts Replacement

In this section, the removing and installing procedure of assembly and unit in field are described. Although this section describes the removing procedure, the installing procedure is basically to conduct the removing one in reverse.

3.1 Precautions Concerning Parts Replacement

3.2 Parts Layout

3.3 Parts Replacement Methods

Copyright 1998, Okidata, Division of OKI America, Inc. All rights reserved. See the OKIDATA Business Partner Exchange (BPX) for any updates to this material. (<http://bpx.okidata.com>)











Service Guide OKIPAGE 18/18n

Chapter D Second / Third Paper Feeder Maint (option)

3.1 Precautions Concerning Parts Replacement

- (1) Parts replacements must be carried out, by first turning the printer power switch off "O" and removing the High Capacity Second / Third Paper Feeder from the printer.
- (2) Do not disassemble the Second/Third Paper Feeder if it is operating normally.
- (3) Establish the extent of disassembly suitable for the purpose of the procedure, and do not disassemble any more than necessary.
- (4) Only specified service tools may be used.
- (5) Disassembly must be carried out according to the prescribed procedures. Parts may be damaged if such procedures are not followed.
- (6) Small parts such as screws and collars can easily be lost, therefore these parts should be temporarily fixed in the original location.
- (7) When handling printed circuit boards, do not use any glove which may generate static electricity.
- (8) Do not place the printed circuit boards directly on the equipment or floor.

Table 3-1 Service Tools

No.	Service Tools	Q'ty	Place of use	Remarks
1	 No. 1-100 Philips screwdriver	1	2~2.5 mm screws	
2	 No. 2-100 Philips screwdriver	1	3~5 mm screws	
3	 No. 3-100 screwdriver	1		
4	 No. 5-200 screwdriver	1		
5	 Digital multimeter	1		
6	 Pliers	1		
7	 Handy cleaner	1		
8	 Connector remover OKI P/N: 4PP4076-5395P1	1		



Service Guide OKIPAGE 18/18n
Chapter D Second / Third Paper Feeder Maint (option)

3.2 Parts Layout

This section describes the layout of the main components.

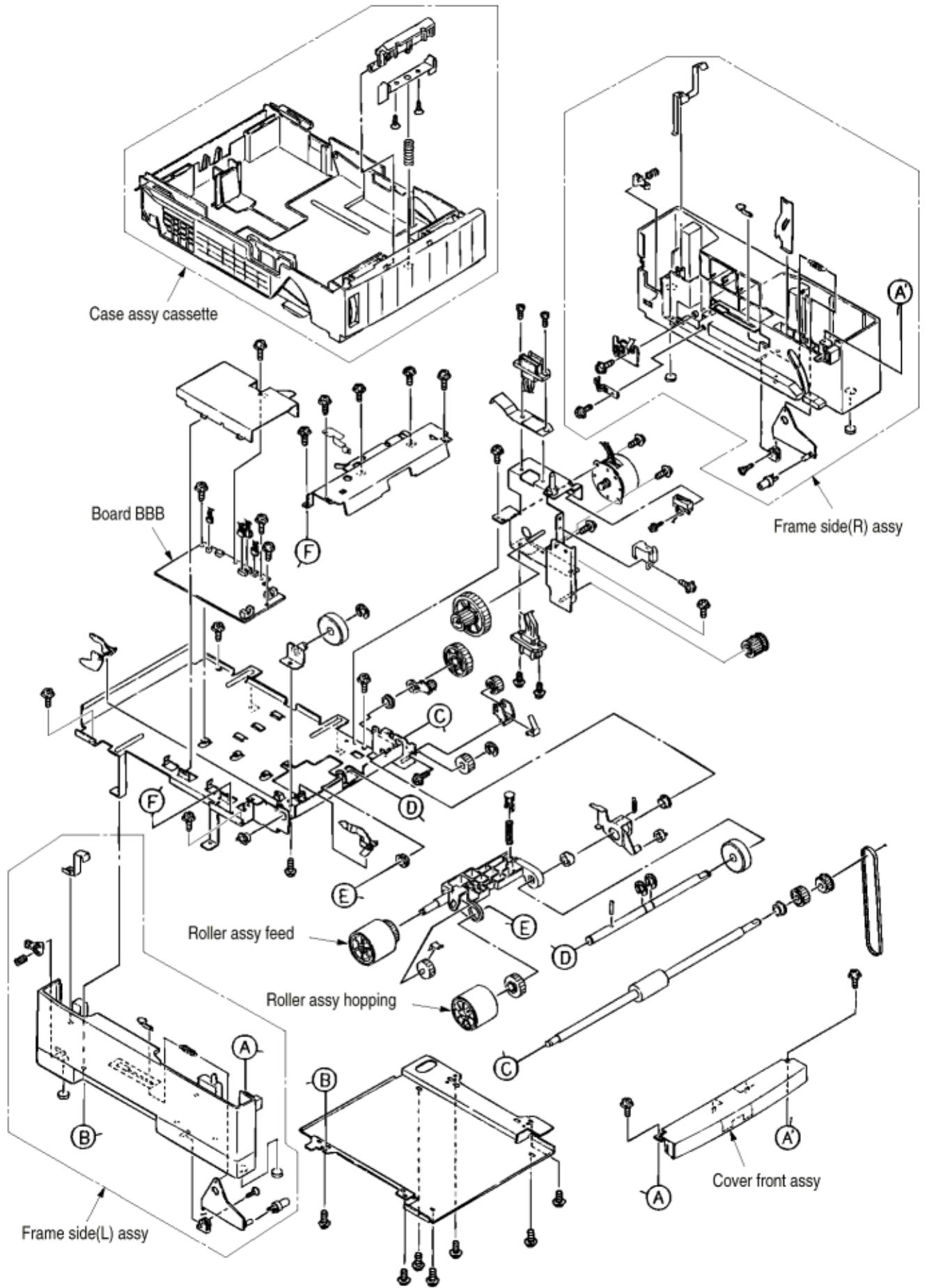

Copyright 1998, Okidata, Division of OKI America, Inc. All rights reserved. See the OKIDATA Business Partner Exchange (BPX) for any updates to this material. (<http://bpx.okidata.com>)



Service Guide OKIPAGE 18/18n

Chapter D Second / Third Paper Feeder Maint (option)

3.3 Parts Replacement Methods

This section describes the parts replacement methods for the components listed in the disassembly order diagram below.

High Capacity

Second / Third Paper Feeder Roller assy hopping, Roller assy feed (3.3.1)

Cover front assy (3.3.2)

Board-BBB (3.3.3)

Lever paper end, Lever paper near end (3.3.4)

Motor (3.3.5)

Connector (IMSA-9714N-14B), Connector (IMSA-9714N-14A) (3.3.6)

Frang Pulley, Pulley Idle, Mini Pitch belt, Plate Earth shaft, Gear double, Tray switch assy (3.3.7)

Roller feed (3.3.8)

Bracket sub roller (3.3.9)

Frame side L (3.3.10)

Frame side R (3.3.11)

Service Guide OKIPAGE 18/18n

Chapter D Second / Third Paper Feeder Maint (option)

3.3.1 Roller assy hopping, Roller assy feed

- (1) Remove the Case assy cassette (1).
- (2) Disengage latches to remove the Roller assy hopping (2).
- (3) Disengage latches to remove the Roller assy feed (3).

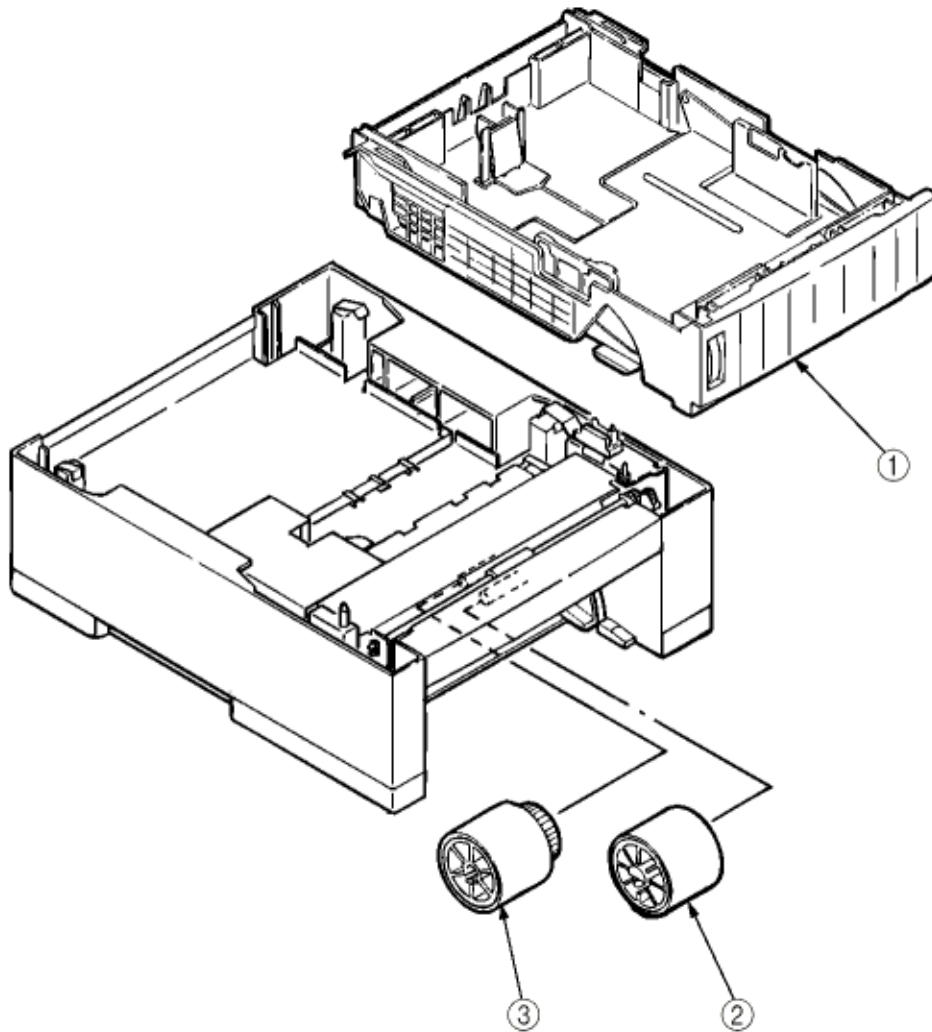



Service Guide OKIPAGE 18/18n
Chapter D Second / Third Paper Feeder Maint (option)

3.3.2 Cover front assy

(1) Unscrew two screws (1) to remove the Cover front assy (2).

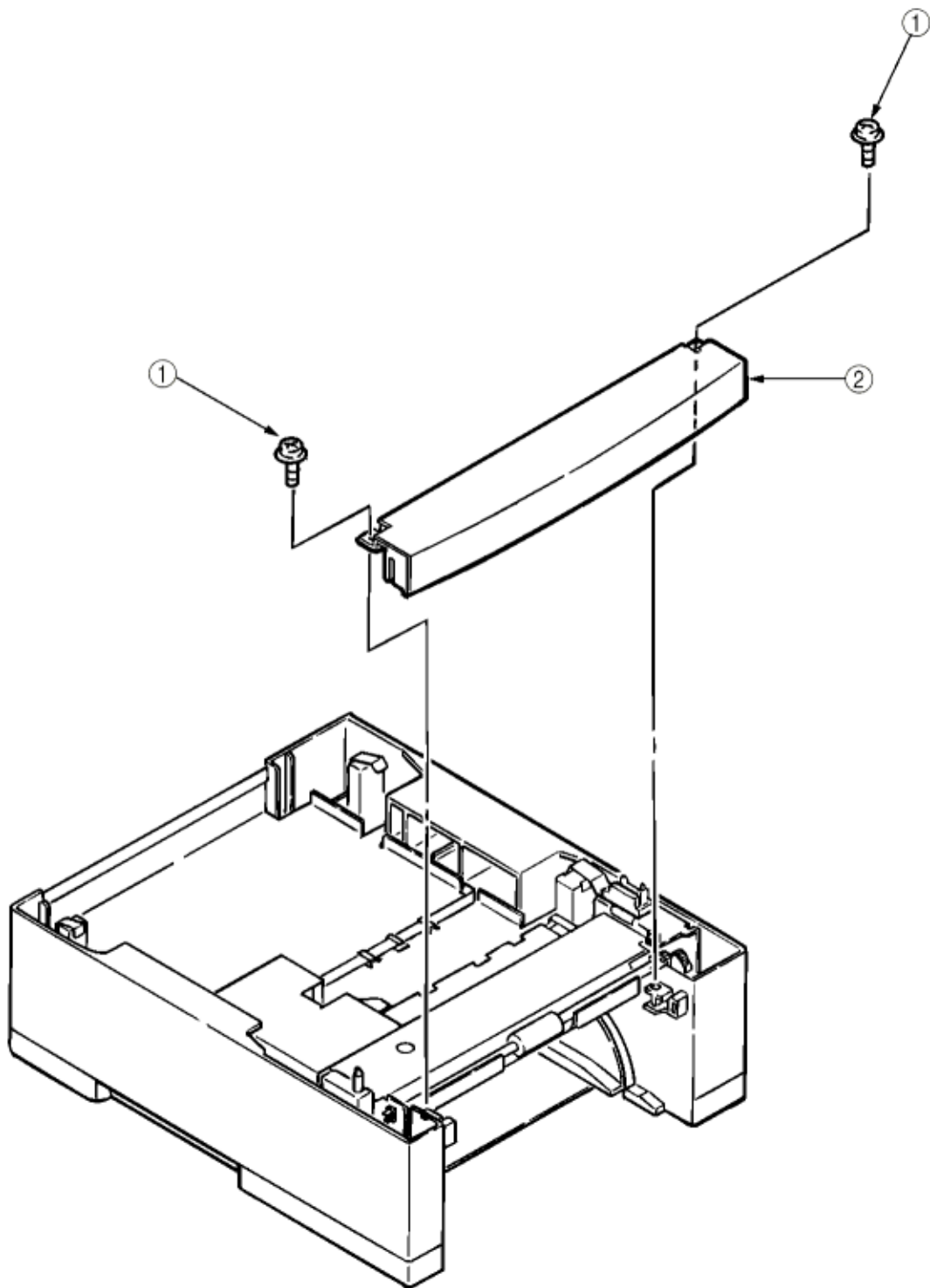

3.3.3 Board-BBB

- (1) Unscrew a screw (1) to remove the PCB cover bracket (2).
- (2) Take away all connectors (3) and three screws (4) to remove the Board-BBB (5).

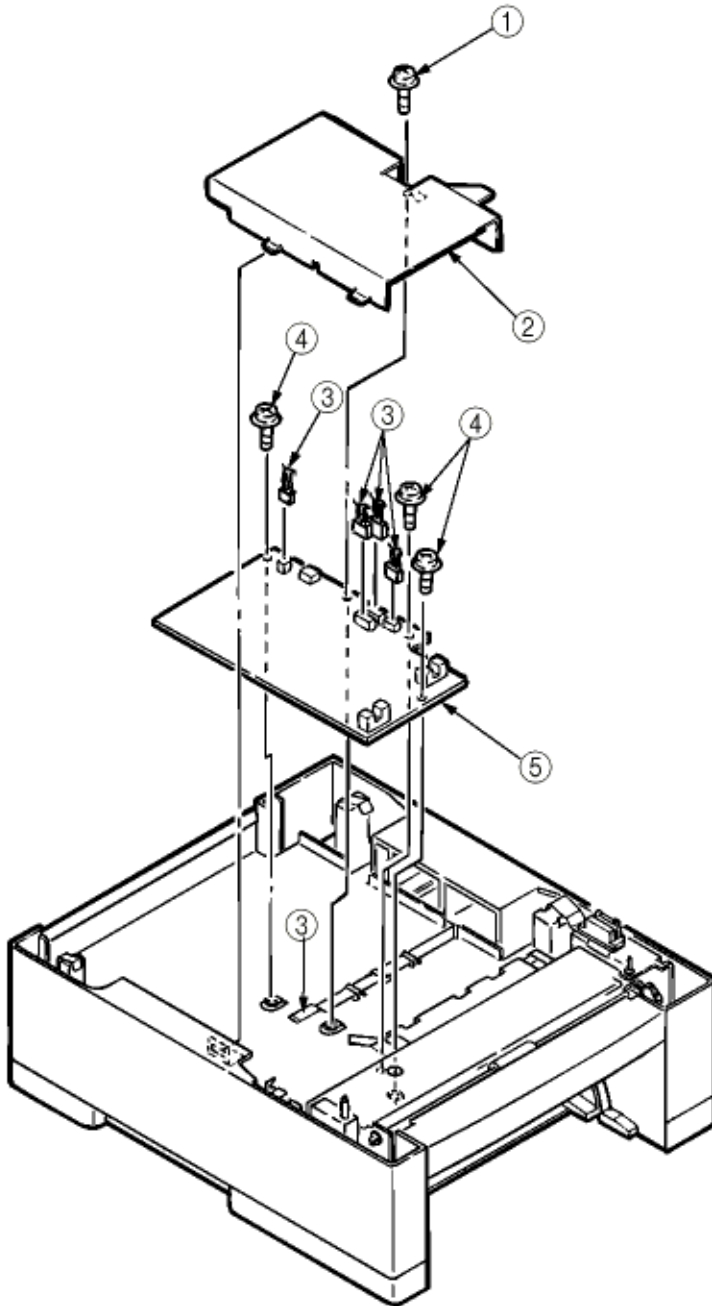

Copyright 1998, Okidata, Division of OKI America, Inc. All rights reserved. See the OKIDATA Business Partner Exchange (BPX) for any updates to this material. (<http://bpx.okidata.com>)

Service Guide OKIPAGE 18/18n

Chapter D Second / Third Paper Feeder Maint (option)

3.3.4 Lever paper end, Lever paper near end

- (1) Unscrew five screws (1) to remove roller cover bracket (2) and PLATE-Earth (L) (3).
- (2) Disengage latches to remove the Lever paper end (4) and Lever paper near end (5).

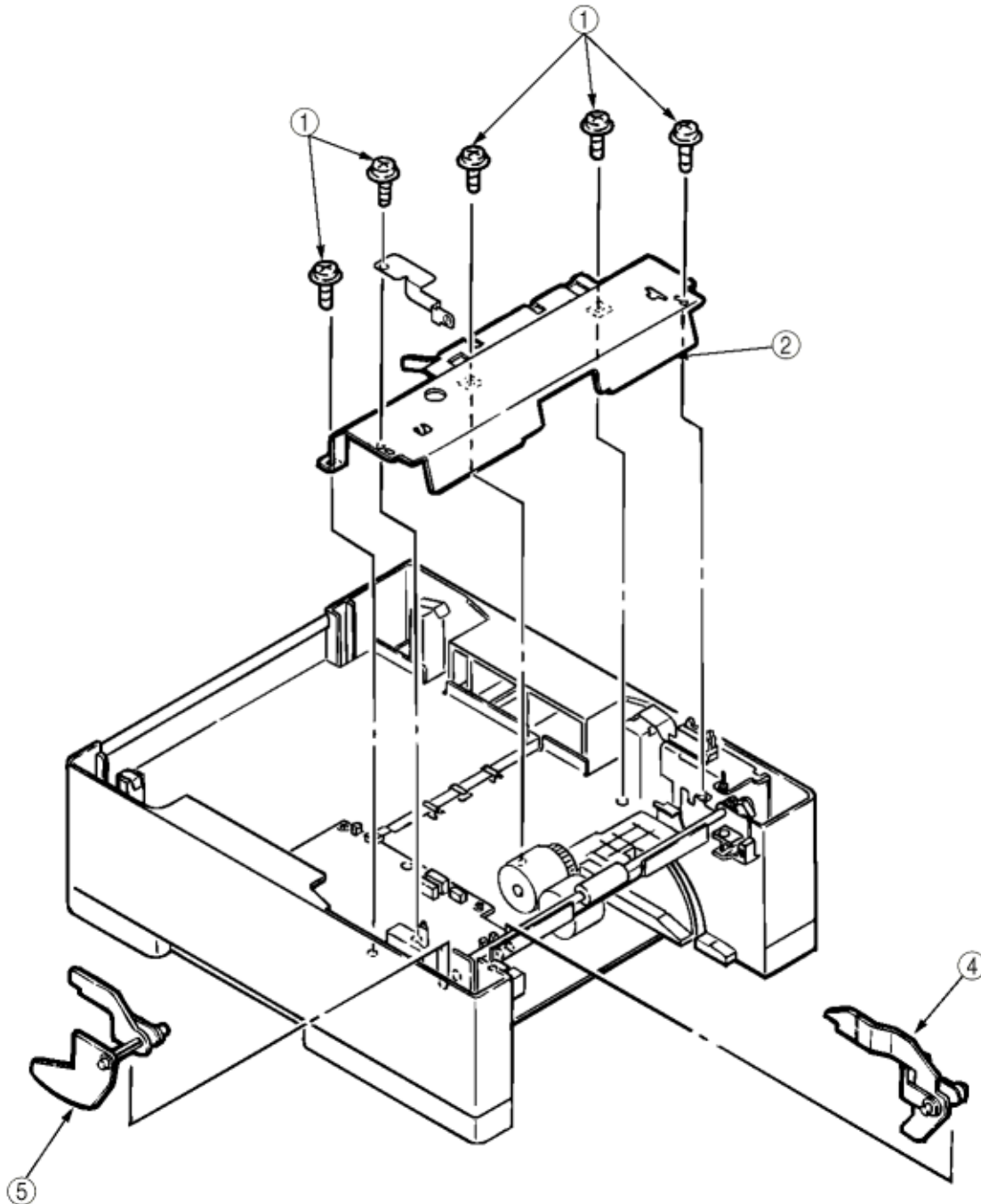

Copyright 1998, Okidata, Division of OKI America, Inc. All rights reserved. See the OKIDATA Business Partner Exchange (BPX) for any updates to this material. (<http://bpx.okidata.com>)



Service Guide OKIPAGE 18/18n
Chapter D Second / Third Paper Feeder Maint (option)

3.3.5 Motor

- (1) Remove the Cover front assy (See section 3.3.2).
- (2) Remove the PCB cover bracket (See section 3.3.3).
- (3) Remove the roller cover bracket (See section 3.3.4).
- (4) Unscrew seven screws (1) to remove the bottom bracket (2).
- (5) Unscrew five screws (3) to remove the Frame side (L) assy (4) and Frame side (R) (5).
- (6) Take away two screws (6) and connector to remove the Motor (7).

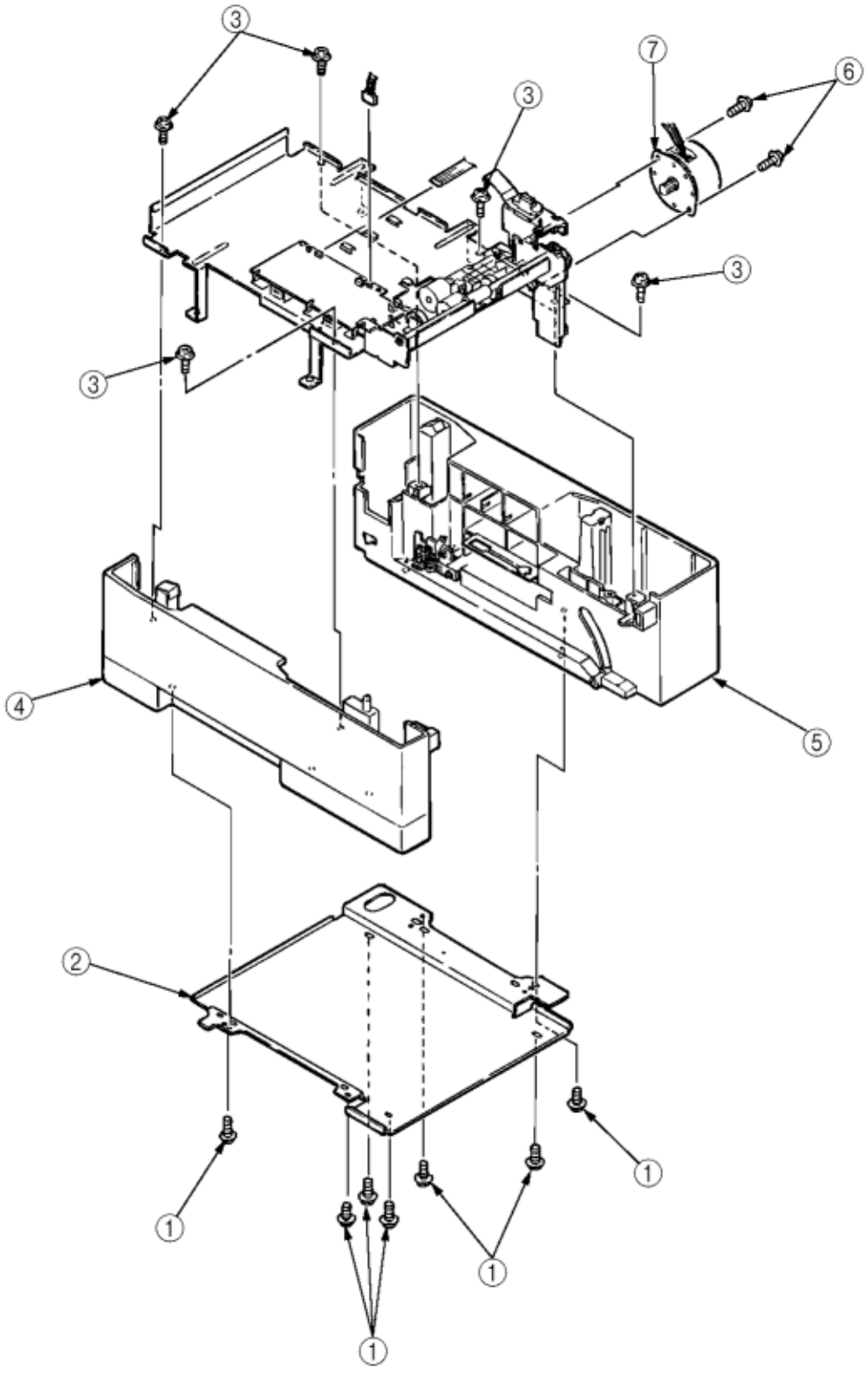

Exchange (BPX) for any updates to this material. (<http://bpx.okidata.com>)



Service Guide OKIPAGE 18/18n
Chapter D Second / Third Paper Feeder Maint (option)

3.3.6 Connector (IMSA-9714N-14B), Connector (IMSA-9714N-14A)

- (1) Remove the Motor (See section 3.3.5).
- (2) Unscrew two screws (1) to remove Connector (IMSA-9714N-14B) (2) and Plate-Earth (FR) (3).
- (3) Unscrew two screws (4) to remove the connector (IMSA-9714N-14A) (5).

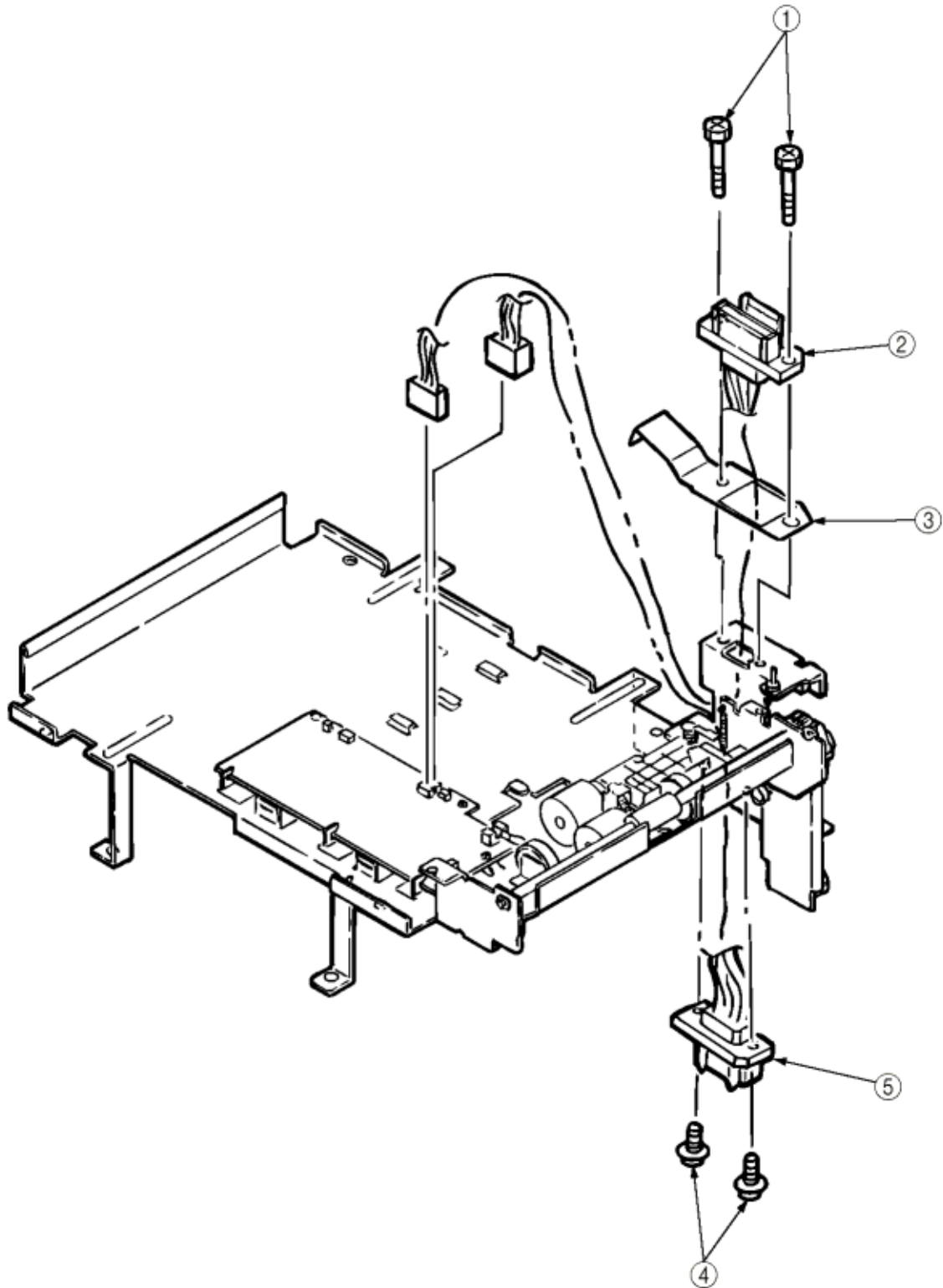

Service Guide OKIPAGE 18/18n

Chapter D Second / Third Paper Feeder Maint (option)

3.3.7 Frange pulley, pulley Idle, Mini pitch belt, Plate Earth shaft, Gear double, Tray switch assy

- (1) Remove the Motor (See section 3.3.5).
- (2) Remove the Connector (See section 3.3.6).
- (3) Unscrew two screws (1) to remove the motor bracket (2).
- (At this time, the Mini pitch belt (3) and Gear double (4) can be removed simultaneously.)
- (4) Disengage latches to remove the Frange pulley (5) and pulley Idle (6).
- (5) Unscrew a screw (7) to remove the Plate Earth shaft (8).
- (6) Unscrew a screw (9) to remove the Tray switch assy (10).

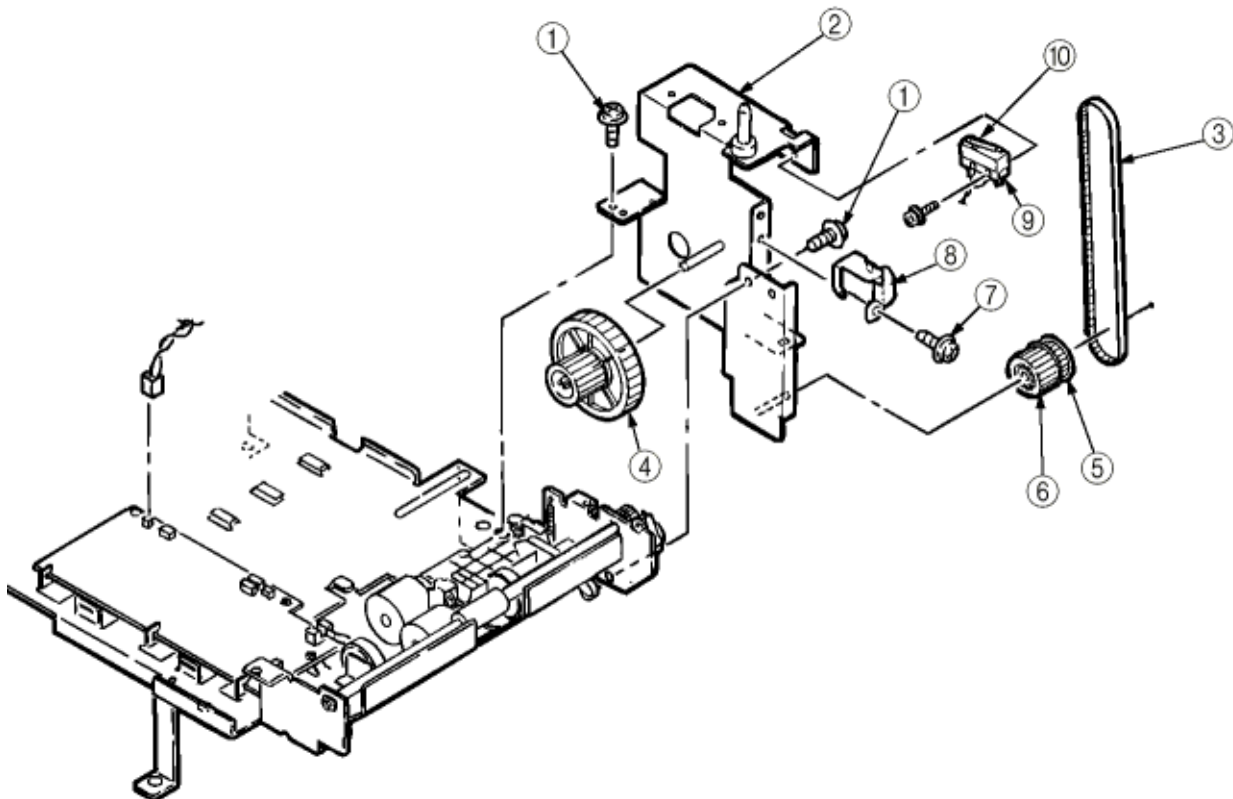



Service Guide OKIPAGE 18/18n

Chapter D Second / Third Paper Feeder Maint (option)

3.3.8 Roller feed

- (1) Remove the Motor (See section 3.3.5).
- (2) Remove the Connector (See section 3.3.6).
- (3) Remove the motor bracket (See section 3.3.7).
- (4) Disengage latches to remove the Feeding bearing 1.
- (5) Disengage latches to remove the Pulley feed 2. (At this time, the Gear feed 3 and Bush 4 can be removed simultaneously.)
- (6) Remove the Roller feed 5.

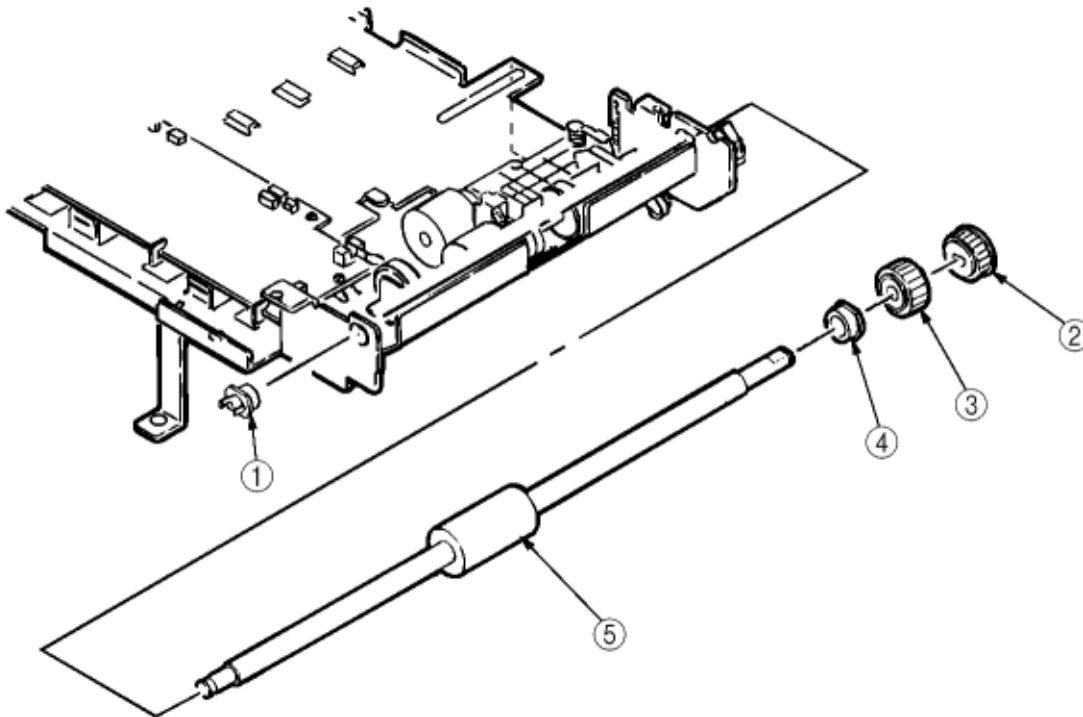



Service Guide OKIPAGE 18/18n

Chapter D Second / Third Paper Feeder Maint (option)

3.3.9 Bracket sub roller

- (1) Remove the Roller assy hopping and Roller assy feed. (See section 3.3.1).
- (2) Remove the Roller feed (See section 3.3.8)
- (3) Unscrew a screw (1) to remove the Bracket joint (2) , Spring joint (3) and Gear joint (4).
- (4) Take away the E-ring (5) to remove the Gear hopping (6).
- (5) Disengage latches to remove the Gear hopping (2nd) (7). (At this time, the Bracket planet assy (8) can be removed simultaneously.)
- (6) Take away two E-ring (9) and pull out the Knock pin (10) to remove the Gear Z38 (11).
- (7) Remove two ADF bearing (12) , Spring release (13) , Bearing F (14) and Space hopping shaft (15) and remove the Shaft hopping (16) , Guide roller (17) , Lever release assy (18) and Bracket sub roller (19).
- (8) Take away the Gear planet (z28) (20) to remove the Planet plate (21).
- (9) Take away the Bracket spring (sub) (22) to remove the Spring sub (23).

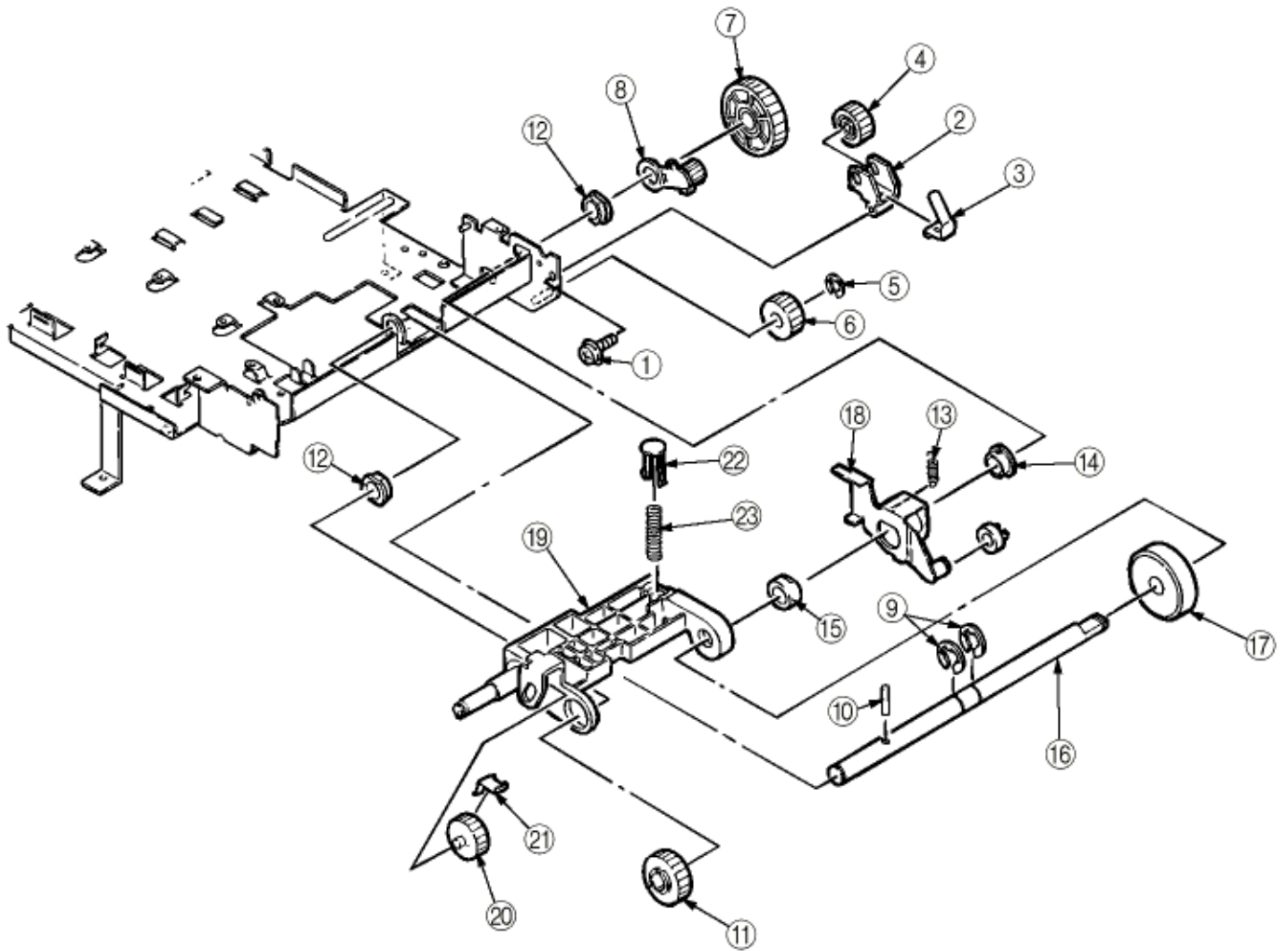

Copyright 1998, Okidata, Division of OKI America, Inc. All rights reserved. See the OKIDATA Business Partner Exchange (BPX) for any updates to this material. (<http://bpx.okidata.com>)



Service Guide OKIPAGE 18/18n
Chapter D Second / Third Paper Feeder Maint (option)

3.3.10 Frame side (L) assy

- (1) Remove the Frame side (L) assy (See section 3.3.5).
- (2) Remove the Plate Earth (BL) (1).
- (3) Take away the Spring (2) to remove the Cassette stopper (3).
- (4) Take away the Spring sheet (4) to remove the Pull block (5). (At this time, Lever link (6) can be removed simultaneously.)
- (5) Unscrew a screw (7) to remove the Link support (8).
- (6) Remove the Roller link (9).
- (7) Remove two Rubber foot (10).

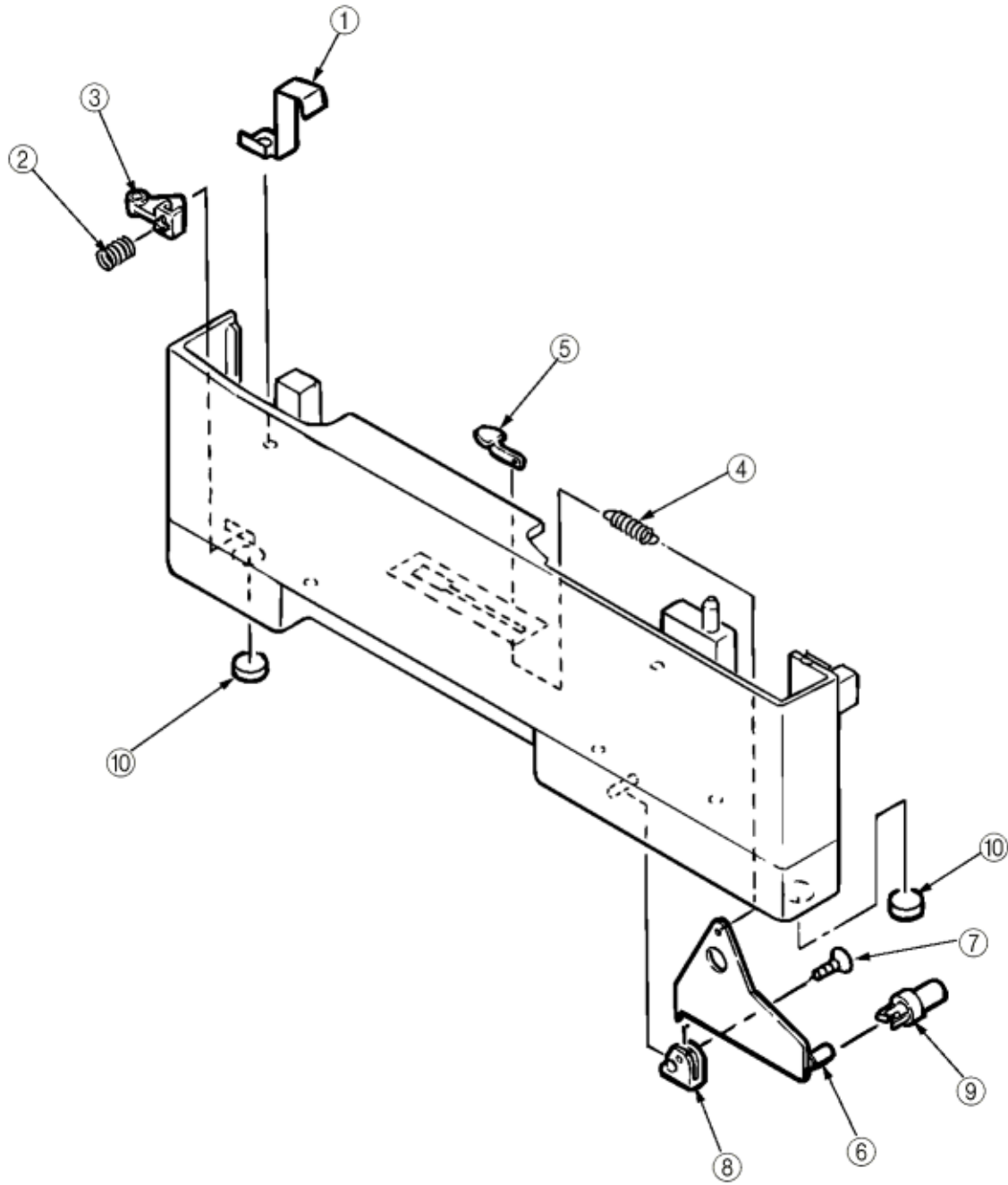

Copyright 1998, Okidata, Division of OKI America, Inc. All rights reserved. See the OKIDATA Business Partner Exchange (BPX) for any updates to this material. (<http://bpx.okidata.com>)



Service Guide OKIPAGE 18/18n
Chapter D Second / Third Paper Feeder Maint (option)

3.3.11 Frame side (R) assy

- (1) Remove the Frame side (R) assy (See section 3.3.5).
- (2) Remove the Plate Earth (BR) (1).
- (3) Take away the Spring (2) to remove the Cassette stopper (3).
- (4) Take away the Spring sheet (4) to remove the Pull block (5). (At this time, Lever link (6) can be removed simultaneously.)
- (5) Unscrew a screw (7) to remove the Link support (8).
- (6) Remove the Roller link (9).
- (7) Remove the Plate earth (10).
- (8) Unscrew a screw (11) to remove the Detector spring (12).
- (9) Unscrew a screw (13) to remove the Board-PXC (14).
- (10) Remove two Rubber foot (15).

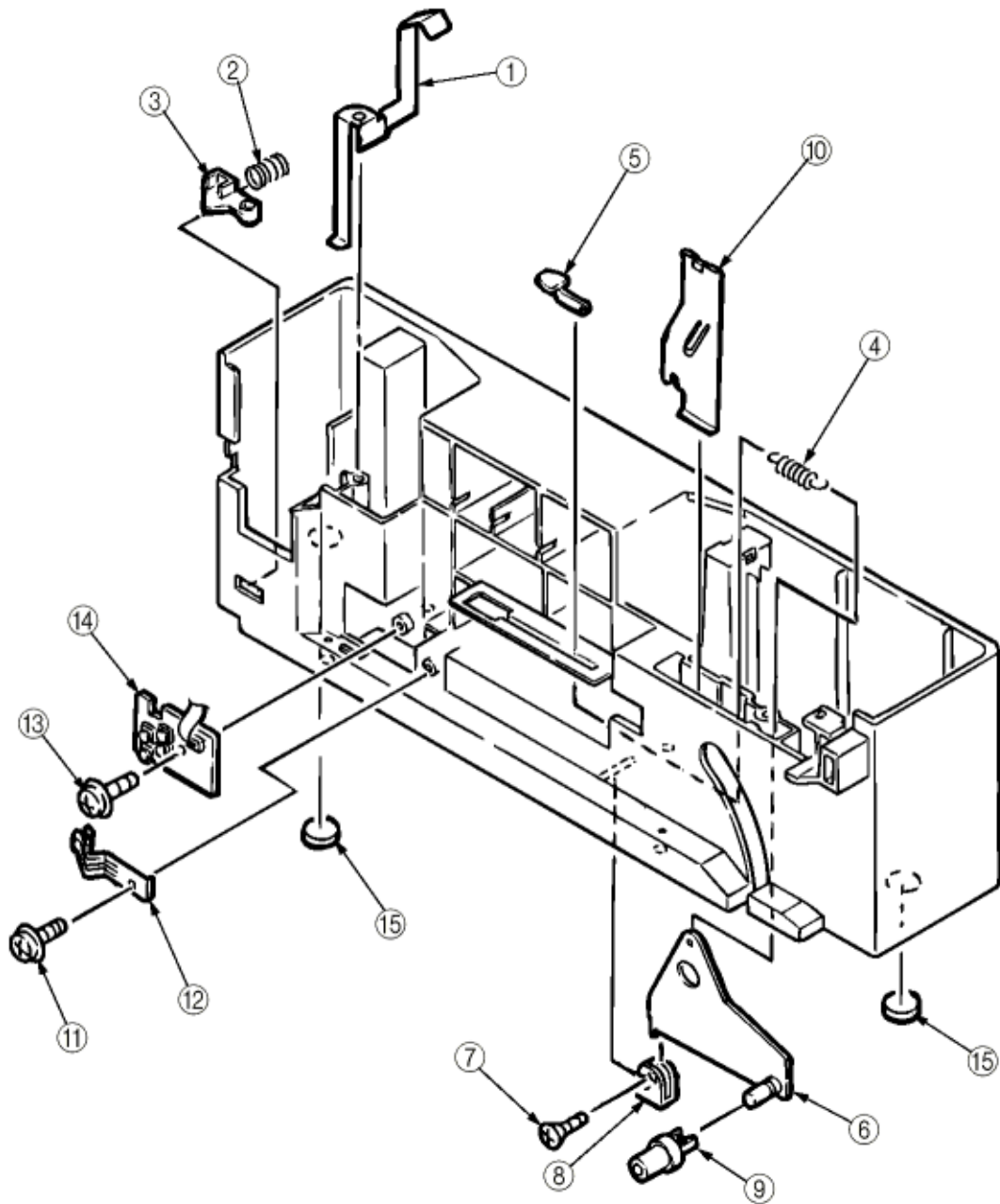

Copyright 1998, Okidata, Division of OKI America, Inc. All rights reserved. See the OKIDATA Business Partner Exchange (BPX) for any updates to this material. (<http://bpx.okidata.com>)



Service Guide OKIPAGE 18/18n
Chapter D Second / Third Paper Feeder Maint (option)

4.0 Troubleshooting

4.1 Precautions Prior to the Troubleshooting

4.2 Preparations for the Troubleshooting

4.3 Troubleshooting Method

Copyright 1998, Okidata, Division of OKI America, Inc. All rights reserved. See the OKIDATA Business Partner Exchange (BPX) for any updates to this material. (<http://bpx.okidata.com>)



Service Guide OKIPAGE 18/18n
Chapter D Second / Third Paper Feeder Maint (option)

4.1 Precautions Prior to the Troubleshooting

- (1) Go through the basic checking items provided in the Operator Guide.
- (2) Obtain detailed information concerning the problem from the user.
- (3) Go through the checking in the conditions similar to that in which the problem occurred.

Copyright 1998, Okidata, Division of OKI America, Inc. All rights reserved. See the OKIDATA Business Partner Exchange (BPX) for any updates to this material. (<http://bpx.okidata.com>)



Service Guide OKIPAGE 18/18n
Chapter D Second / Third Paper Feeder Maint (option)

4.2 Preparations for the Troubleshooting

(1) Display on the Operator panel

The status of the problem is displayed on the LCD (Liquid Crystal Display) on the Operator panel. Go through the appropriate troubleshooting procedures according to the messages displayed on the LCD.

Copyright 1998, Okidata, Division of OKI America, Inc. All rights reserved. See the OKIDATA Business Partner Exchange (BPX) for any updates to this material. (<http://bpx.okidata.com>)



Service Guide OKIPAGE 18/18n

Chapter D Second / Third Paper Feeder Maint (option)

4.3 Troubleshooting Method

When a problem occurs, go through the troubleshooting according to the following procedure.

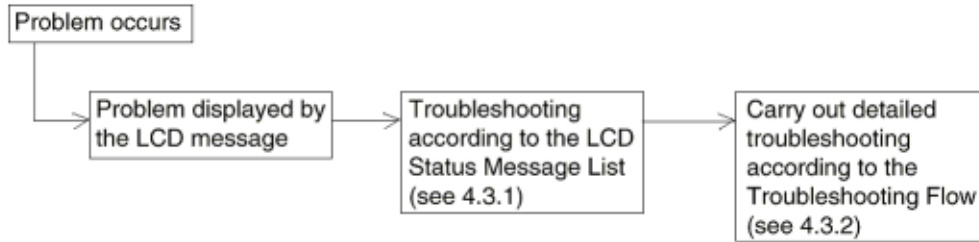



Service Guide OKIPAGE 18/18n
Chapter D Second / Third Paper Feeder Maint (option)

4.3.1 LCD Status Message List

The listing of the statuses and problems displayed in the form of messages on the LCD is provided in Table 4-1.

Classification	LCD Status Message	Description	Recover Method
Jam error	<div style="border: 1px solid black; padding: 2px; width: fit-content;">PAPER INPUT JAM CHECK TRAY *</div> <div style="border: 1px solid black; padding: 2px; width: fit-content; margin-top: 5px;">PAPER FEED JAM CHECK TRAY *</div>	Notifies of occurrence of jam while the paper is being fed from the Second / Third Paper Feeder	<ul style="list-style-type: none"> - Check the paper in the Second / Third Paper Feeder. Carry out the recovery printing by opening the cover, removing jammed paper and closing the cover, and then turning the error display off. - When the problem occurs frequently, go through the Troubleshooting.
Paper size error	<div style="border: 1px solid black; padding: 2px; width: fit-content;">ERROR PAPER SIZE CHECK TRAY *</div>	Notifies of incorrect size paper feeding from the Second / Third Paper Feeder.	<ul style="list-style-type: none"> - Check the paper in the Second / Third Paper Feeder. Also check to see if there was a feeding of multiple sheets. Carry out the recovery printing by opening the cover, and then turning the error display off.
Tray paper Error	<div style="border: 1px solid black; padding: 2px; width: fit-content;">PAPER OUT mmmmmmmm TRAY *</div> <p>mmmmmmmm: Paper size in the tray being selected</p>	Notifies of no paper or paper cassettes state of the Second / Third Paper Feeder.	<ul style="list-style-type: none"> - Load the paper or paper cassette in the Second / Third Paper Feeder.
Interface timeout	<div style="border: 1px solid black; padding: 2px; width: fit-content;">ERROR 81</div>	Notifies of occurrence of interface timeout between the printer and the Second / Third Paper Feeder.	<ul style="list-style-type: none"> - Verify connection of Board - BBB and square-shaped connector. Replace the square-shaped connector if necessary. - Replace Board - BBB.

* : 2 or 3



Service Guide OKIPAGE 18/18n
Chapter D Second / Third Paper Feeder Maint (option)

4.3.2 Troubleshooting Flow

- (JAM error)

Paper Input Jam

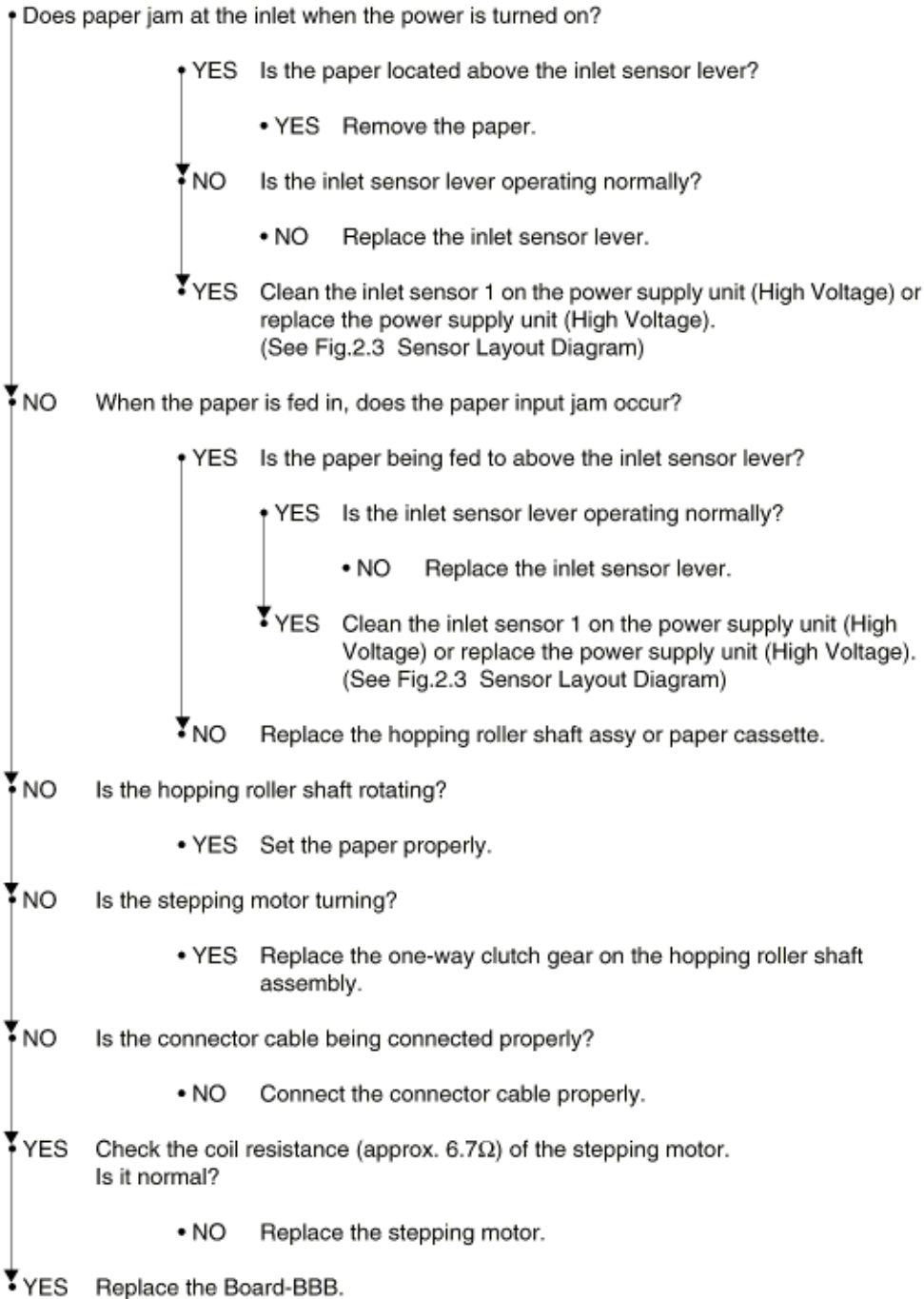



Service Guide OKIPAGE 18/18n
Chapter D Second / Third Paper Feeder Maint (option)

5.0 Connection Diagram

5.1 Interconnection Diagram

5.2 PCB Layout

Copyright 1998, Okidata, Division of OKI America, Inc. All rights reserved. See the OKIDATA Business Partner Exchange (BPX) for any updates to this material. (<http://bpx.okidata.com>)



Service Guide OKIPAGE 18/18n
Chapter D Second / Third Paper Feeder Maint (option)

5.1 Interconnection Diagram

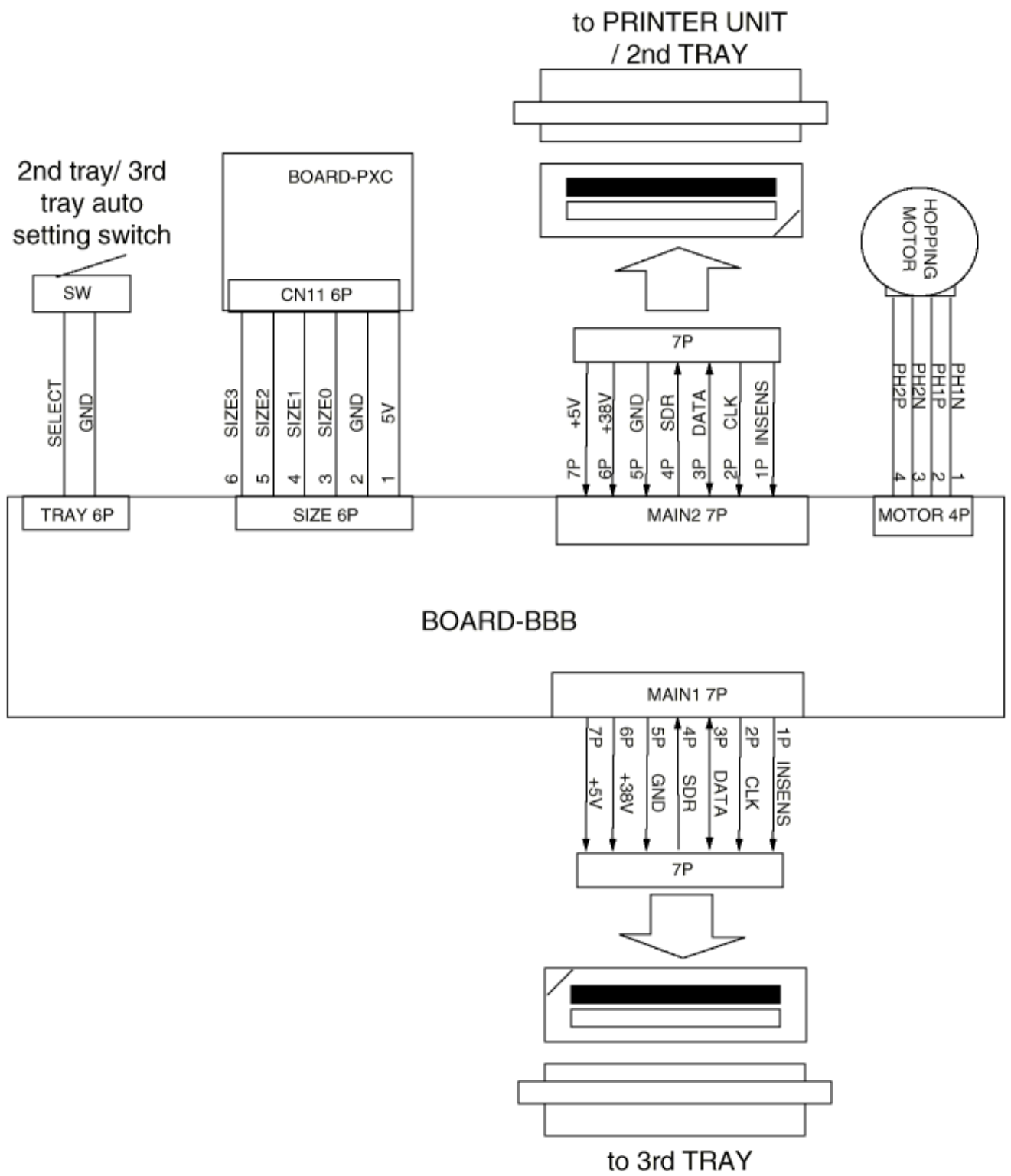

Copyright 1998, Okidata, Division of OKI America, Inc. All rights reserved. See the OKIDATA Business Partner Exchange (BPX) for any updates to this material. (<http://bpx.okidata.com>)

5.2 PCB Layout

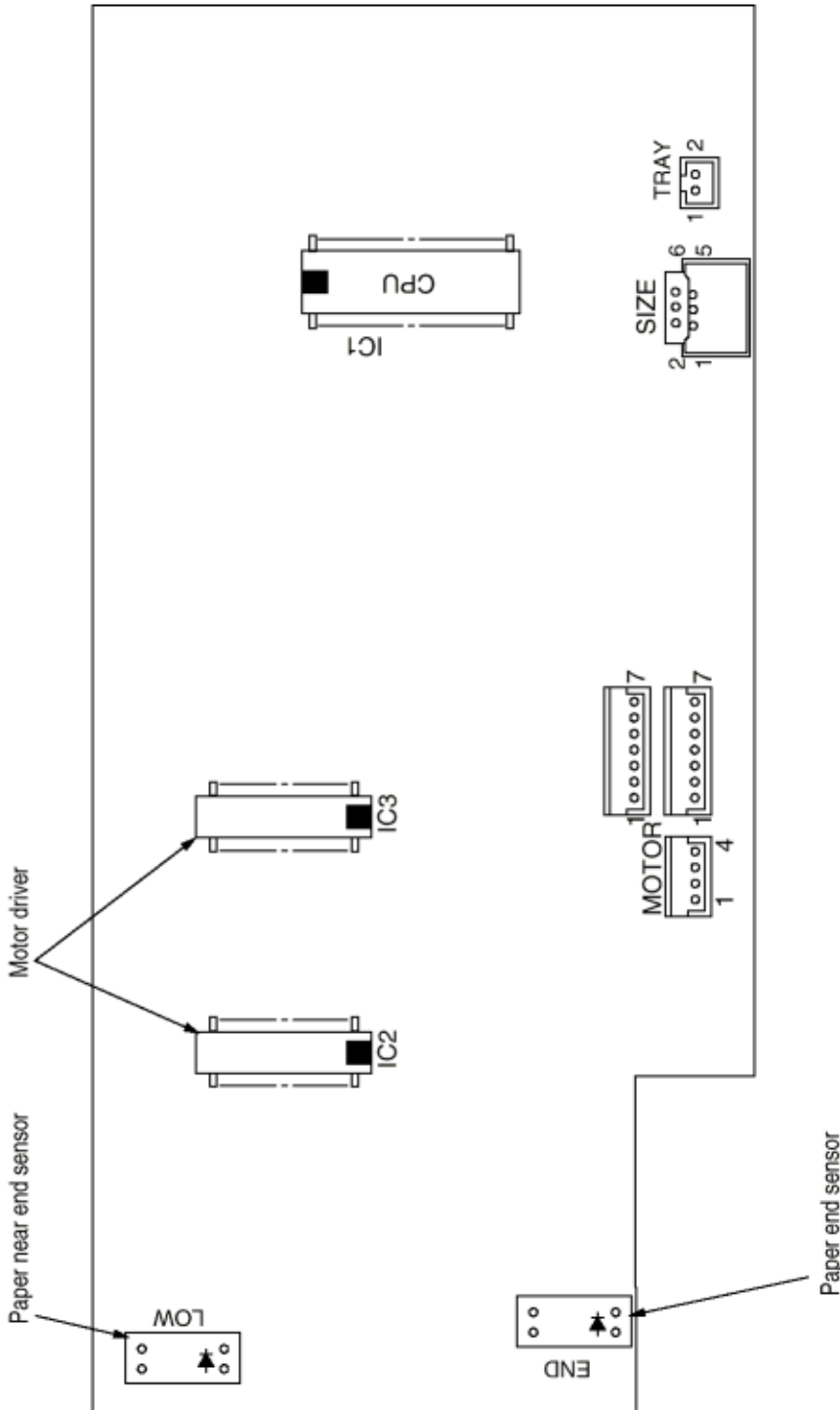

Copyright 1998, Okidata, Division of OKI America, Inc. All rights reserved. See the OKIDATA Business Partner Exchange (BPX) for any updates to this material. (<http://bpx.okidata.com>)



Service Guide OKIPAGE 18/18n
Chapter D Second / Third Paper Feeder Maint (option)

6.0 Parts List

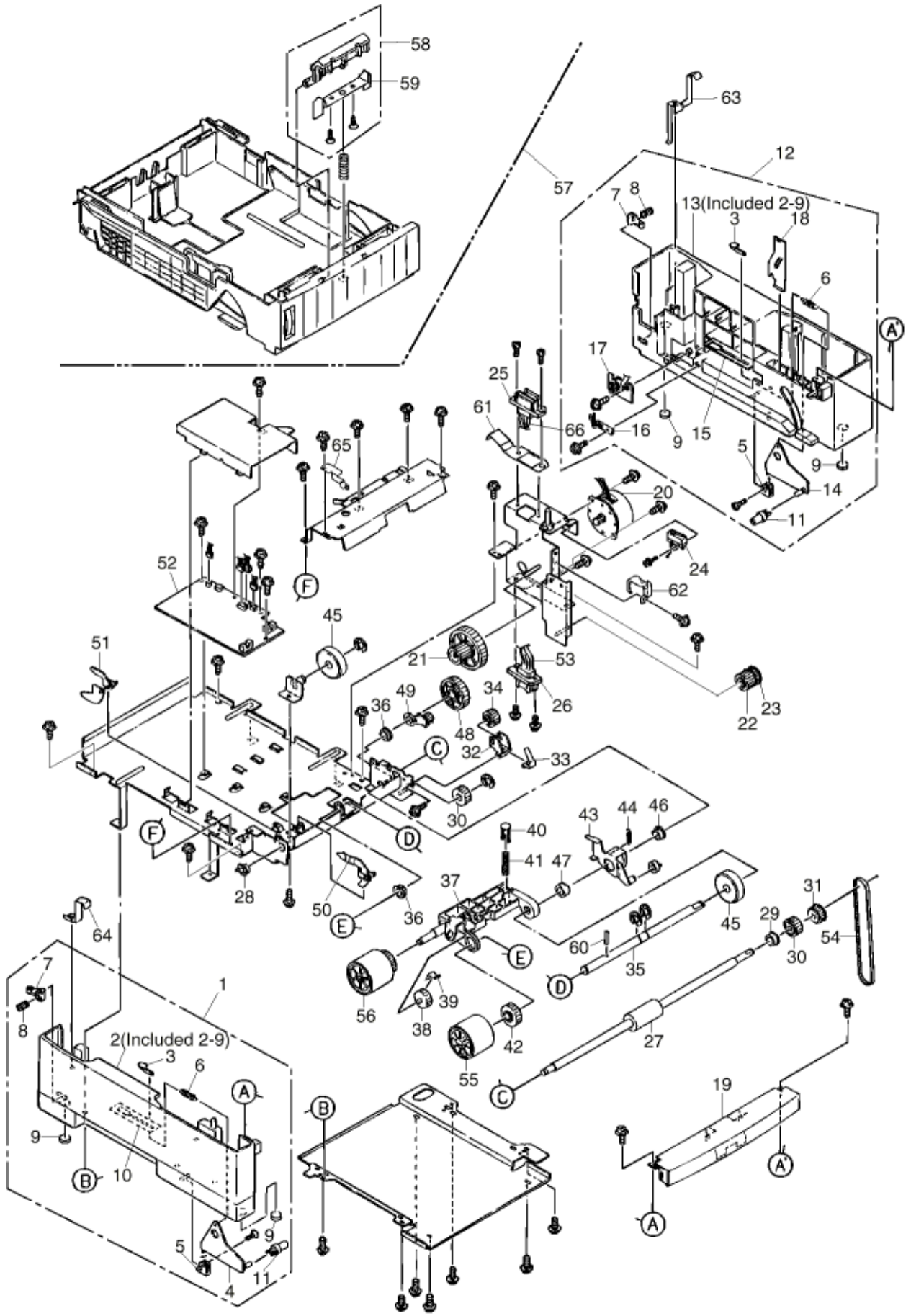

No.	Part No.	Name	Qty	Recommended Qty			Remarks
				50	100	1000	
1	40346701	Frame side (L) assy	1	1	3	6	#
2	40488701	Guide cassette L	1	1	3	6	# For Maintenance
3	51500301	Pull block	2	2	6	12	#
4	40349102	Lever link (caulking)	1	1	3	6	
5	50516801	Link support	2	2	6	12	
6	40607201	Spring - Sheet	2	0	6	12	#
7	50607201	Cassette stopper	2	2	6	12	
8	50928801	Spring	2	0	6	12	
9	50806102	Rubber foot	4	4	12	24	
10	51024701	Guide rail plate L	1	1	3	6	
11	40349701	Roller link	2	2	6	12	#
12	40346801	Frame side (R) assy	1	1	3	6	#
13	40488801	Guide cassette R	1	1	3	6	# For Maintenance
14	40349101	Lever link (Caulking)	1	1	3	6	#
15	51024801	Guide rail plate R	1	1	3	6	
16	50928901	Detector spring	1	1	3	6	
17	40368303	Board - PXC	1	1	3	6	#
18	40433001	Plate earth (R)	1	1	3	6	#
19	40347001	Cover front assy	1	1	3	6	#
20	40366501	Motor	1	1	3	6	#
21	40247001	Gear double	1	1	3	6	#
22	40348301	Pulley idle	1	1	3	6	#
23	40422101	Flang pulley	1	1	3	6	#
24	40444301	Tray switch assy	1	2	6	12	#
25	56731641	Connector (IMSA-9714N-14B)	1	0	3	6	To Printer or 2nd Tray
26	56731640	Connector (IMSA-9714N-14A)	1	0	3	6	To 3rd Tray
27	40247301	Roller feed	1	1	3	6	#
28	51609401	Feeding bearing	1	1	3	6	
29	51607301	Bush	1	1	3	6	
30	40247101	Gear feed	2	2	6	12	#
31	40247201	Pulley feed	1	1	3	6	#
32	40247801	Bracket joint	1	1	3	6	#
33	40433401	Spring joint	1	1	3	6	#
34	40247701	Gear joint	1	1	3	6	#
35	40247501	Shaft hopping	1	1	3	6	#
36	51608901	ADF bearing	2	2	6	12	
37	40433701	Bracket sub roller (caulking)	1	1	3	6	#
38	40317701	Gear planet (z28)	1	1	3	6	#
39	40358101	Plate planet	1	0	3	6	#
40	40367101	Bracket spring (sub)	1	0	3	6	#
41	40607301	Spring sub roller	1	0	3	6	#
42	40317601	Gear z38	1	1	3	6	#
43	40385901	Lever release assy	1	0	3	6	#
44	40363301	Spring release	1	0	3	6	#
45	40442501	Guide roller	2	0	6	12	#
46	51608201	Bearing F	1	0	3	6	
47	40363401	Space hopping shaft	1	0	3	6	#
48	40348401	Gear hopping (2nd)	1	1	3	6	#
49	40348501	Bracket planet assy	1	1	3	6	#
50	40317901	Lever paper end	1	1	3	6	#
51	40318001	Lever paper near end	1	1	3	6	
52	40387101	Board - BBB	1	0	3	6	
53	40375101	connection code - wire	1	0	3	6	To 3rd Tray

54	51305201	Mini pitch belt	1	1	3	6	
55	40371301	Roller assy hopping	1	2	6	12	
56	40313201	Roller assy feed	1	2	6	12	
57	40378401	Case assy cassette	1	1	3	6	
58	40927901	Separator frame assy	1	1	3	6	
59	see #58	PLATE - Damper	1	0	3	6	
60	50608101	Knock Pin	1	1	3	6	
61	40387401	Plate - Earth (FR)	1	1	3	6	
62	40387601	Plate - Earth (Shaft)	1	1	3	6	
63	40387501	Plate - Earth (BR)	1	1	3	6	
64	40387301	Plate - Earth (BL)	1	1	3	6	
65	40432901	Plate - Earth (R)	1	1	3	6	
66	40583601	Core Assy - 2nd Tray	1	0	3	6	To Printer or 2nd Tray

Copyright 1998, Okidata, Division of OKI America, Inc. All rights reserved. See the OKIDATA Business Partner Exchange (BPX) for any updates to this material. (<http://bpx.okidata.com>)



Service Guide OKIPAGE 18/18n Chapter E Multi-Purpose Feeder Maintenance

1.0 Outline

This Handbook is intended for the service personnel and describes the field maintenance methods for Multi Feeder option of the OKIPAGE 18 Series LED Page Printer.

Refer to the USER'S MANUAL for operating instructions.

1.1 Functions

1.2 External View and Component Names

Copyright 1998, Okidata, Division of OKI America, Inc. All rights reserved. See the OKIDATA Business Partner Exchange (BPX) for any updates to this material. (<http://bpx.okidata.com>)



Service Guide OKIPAGE 18/18n

Chapter E Multi-Purpose Feeder Maintenance

1.1 Functions

This Multi Feeder is installed on the front section of the printer, and it supplies paper automatically through the operation of hopping motor, which is driven by signals sent from the printer.

The main functions are the followings:

- Paper that can be used:

Paper type	Paper size	Quantity of paper
Plain paper	A6 (106 x 148 mm) ~ A4	64 - 90 g/m ²
Thick paper, OHP film		64 - 90 g/m ²
Post card, label sheet	Post card - A4-size equivalent	64 - 128 g/m ²
Envelope	C5, DL, COM-10, COM-9, Monarch	64 - 90 g/m ²

* approximately 50 sheets of envelopes can be set at a time.

Copyright 1998, Okidata, Division of OKI America, Inc. All rights reserved. See the OKIDATA Business Partner Exchange (BPX) for any updates to this material. (<http://bpx.okidata.com>)

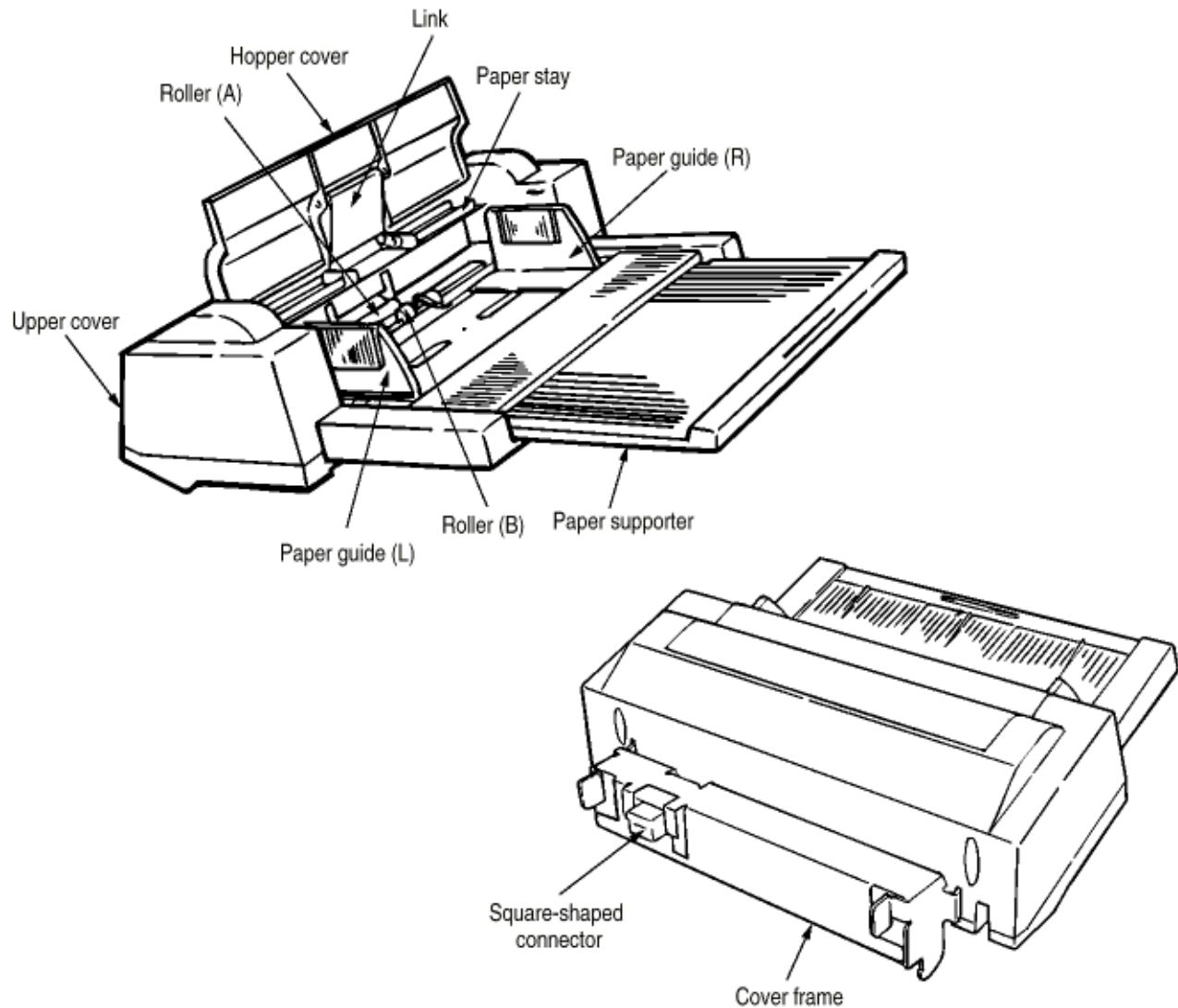
Service Guide OKIPAGE 18/18n
Chapter E Multi-Purpose Feeder Maintenance**1.2 External View and Component Names**



Service Guide OKIPAGE 18/18n
Chapter E Multi-Purpose Feeder Maintenance

2.0 Mechanism Description

2.1 General Mechanism

2.2 Hopper Mechanism

Copyright 1998, Okidata, Division of OKI America, Inc. All rights reserved. See the OKIDATA Business Partner Exchange (BPX) for any updates to this material. (<http://bpx.okidata.com>)



Service Guide OKIPAGE 18/18n

Chapter E Multi-Purpose Feeder Maintenance

2.1 General Mechanism

The sheet (or envelope) at the very bottom of the stack is fed into the printer, one at a time, when the Multi Feeder receives the signal from the printer.

(1) First, the hopping motor rotates in the direction of arrow D. The planet gear F moves to the direction of arrow G, and drives rollers A and B. The roller C is linked to pulley I which is on the same shaft as roller A, and it also turns at the same time as roller A. The paper is fed for a predesignated distance until the leading edge reaches roller C.

(2) Next, the hopping motor rotates in the direction of arrow E. The planet gear F moves to the direction of arrow H, and drives idle gear J. The rotation of idle gear J is transmitted to the gears linked to it, and drives pulley I on the same shaft as roller A, turning roller C to feed the paper into the printer, until it reaches the registration roller of the printer. During this process, a one-way bearing is engaged at pulley I so that the rotation of pulley I is not transmitted to roller A, preventing any feeding of papers by roller A.

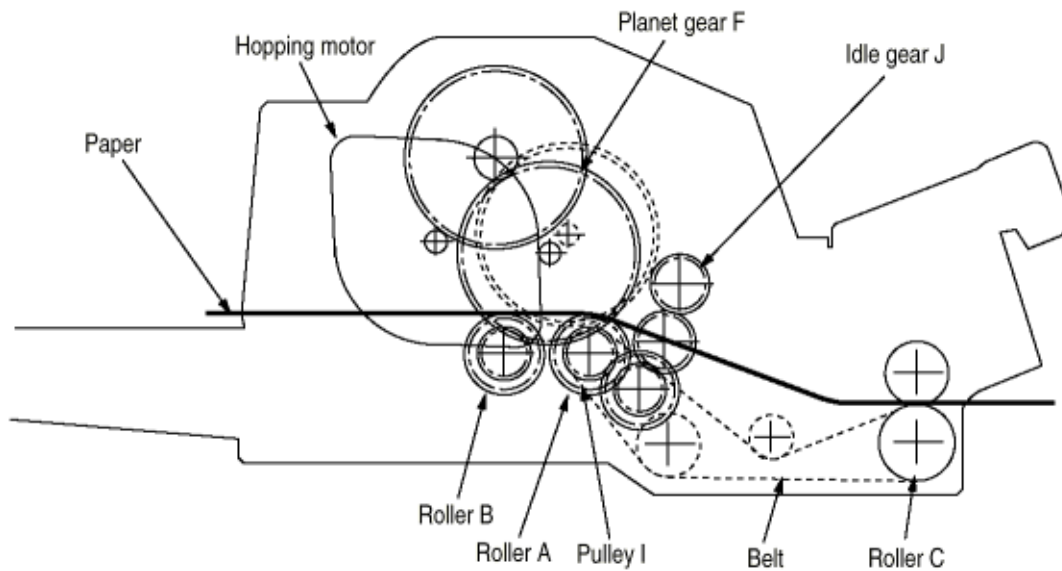

Service Guide OKIPAGE 18/18n

Chapter E Multi-Purpose Feeder Maintenance

2.2 Hopper Mechanism

The hopper automatically feeds the printer with the paper being set, single sheet at a time.

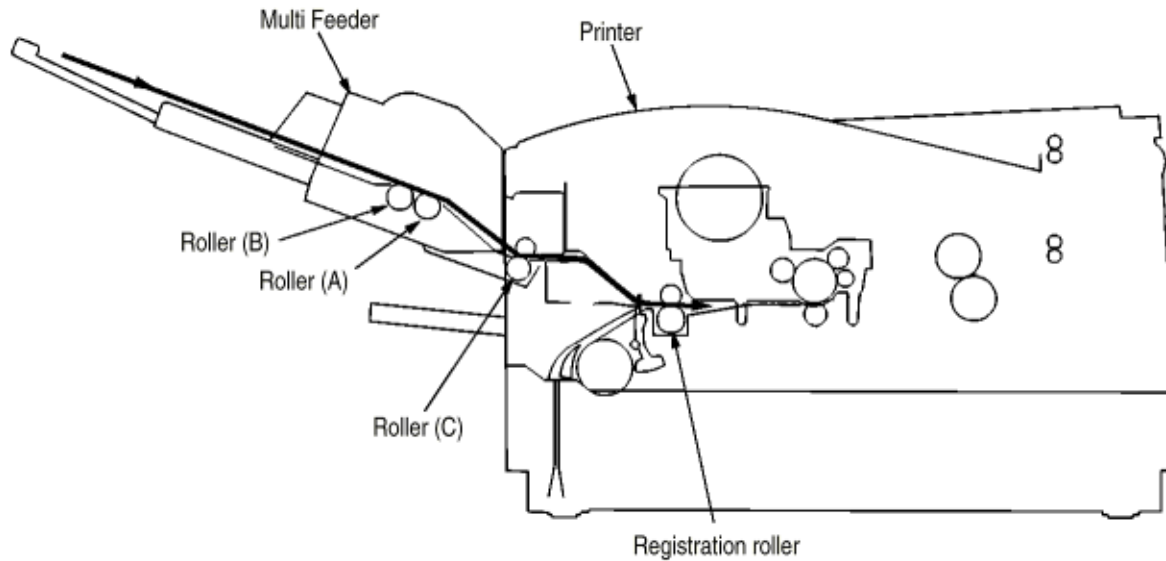



Service Guide OKIPAGE 18/18n

Chapter E Multi-Purpose Feeder Maintenance

3.0 Parts Replacement

This section covers the procedures for the disassembly, reassembly and installations in the field. This section describes the disassembly procedures, and for reassembly procedures, basically proceed with the disassembly procedures in the reverse order.

3.1 Precautions Concerning Parts Replacement

3.2 Parts Layout

3.3 Parts Replacement Methods

Copyright 1998, Okidata, Division of OKI America, Inc. All rights reserved. See the OKIDATA Business Partner Exchange (BPX) for any updates to this material. (<http://bpx.okidata.com>)



Service Guide OKIPAGE 18/18n

Chapter E Multi-Purpose Feeder Maintenance









3.1 Precautions Concerning Parts Replacement

- (1) Parts replacements must be carried out, by first turning the printer power switch off "O" and removing the Multi Feeder from the printer.
- (2) Do not disassemble the Multi Feeder if it is operating normally.
- (3) Establish the extent of disassembly suitable for the purpose of the procedure, and do not disassemble any more than necessary.
- (4) Only specified service tools may be used.
- (5) Disassembly must be carried out according to the prescribed procedures. Parts may be damaged if such procedures are not followed.
- (6) Small parts such as screws and collars can easily be lost, therefore these parts should be temporarily fixed in the original location.
- (7) When handling printed circuit boards, do not use any glove which may generate static electricity.
- (8) Do not place the printed circuit boards directly on the equipment or floor.

[Service Tools]

Table 3-1 shows the tools required for the replacement of printed circuit boards and units in the field.

Table 3-1 Service Tools

No.	Service Tools	Q'ty	Place of use	Remarks
1	 No. 1-100 Philips screwdriver	1	2~2.5 mm screws	
2	 No. 2-100 Philips screwdriver	1	3~5 mm screws	
3	 No. 3-100 screwdriver	1		
4	 No. 5-200 screwdriver	1		
5	 Digital multimeter	1		
6	 Pliers	1		
7	 Handy cleaner	1		
8	 Connector remover OKI P/N: 4PP4076-5395P1	1		



3.2 Parts Layout

This section describes the layout of the main components.

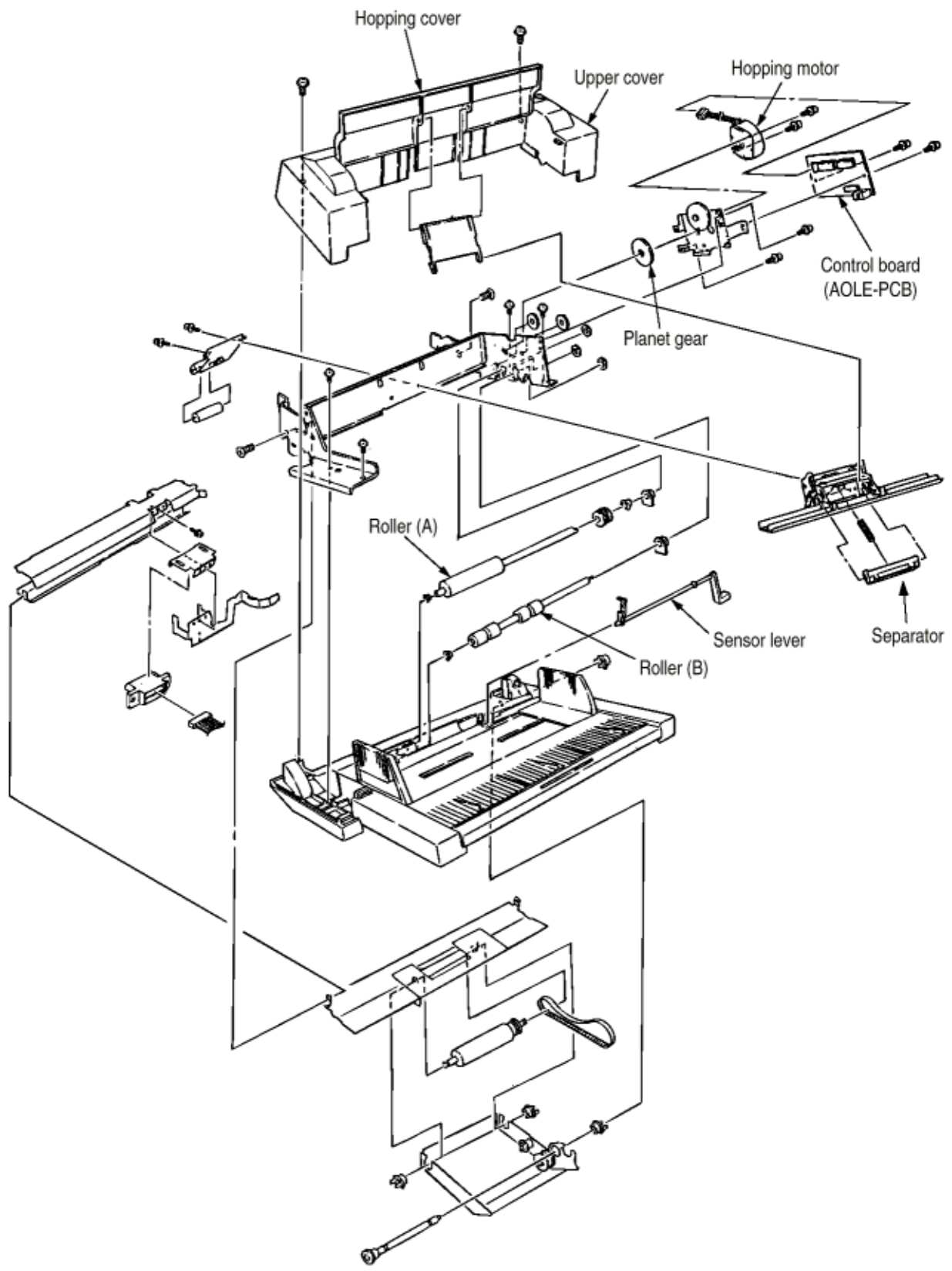

Copyright 1998, Okidata, Division of OKI America, Inc. All rights reserved. See the OKIDATA Business Partner Exchange (BPX) for any updates to this material. (<http://bpx.okidata.com>)



Service Guide OKIPAGE 18/18n
Chapter E Multi-Purpose Feeder Maintenance

3.3 Parts Replacement Methods

This section describes the parts replacement methods for the components listed in the disassembly order diagram below.

Multi Feeder Separator (3.3.1)	AOLE-PCB (3.3.2) Square-shaped connector (3.3.3) Hopping motor (3.3.4) Planet gear (3.3.5) Roller B (3.3.6) Roller A (3.3.7) Mini pitch belt & Feed roller (3.3.8)
---------------------------------------	--



Service Guide OKIPAGE 18/18n

Chapter E Multi-Purpose Feeder Maintenance

3.3.1 Separator

- (1) Turn the printer power off and remove the Multi Feeder.
- (2) Disengage the link and hopper cover.
- (3) Remove two screws (1), disengage two locks of the upper cover (2) using a flat-head screwdriver, and remove the upper cover (2).
- (4) Remove two pan-head screws (3) and remove the cover frame (4).
- (5) Disengage the plate and the frame. (Refer to 3.3.6.)
- (6) Remove two screws (5) and remove the separator assy (6).
- (7) Lift the paper stay (7) and disengage it from the separator bracket (8), then remove the separator 9. The spring (10) comes off at the same time, so be careful not to lose it.

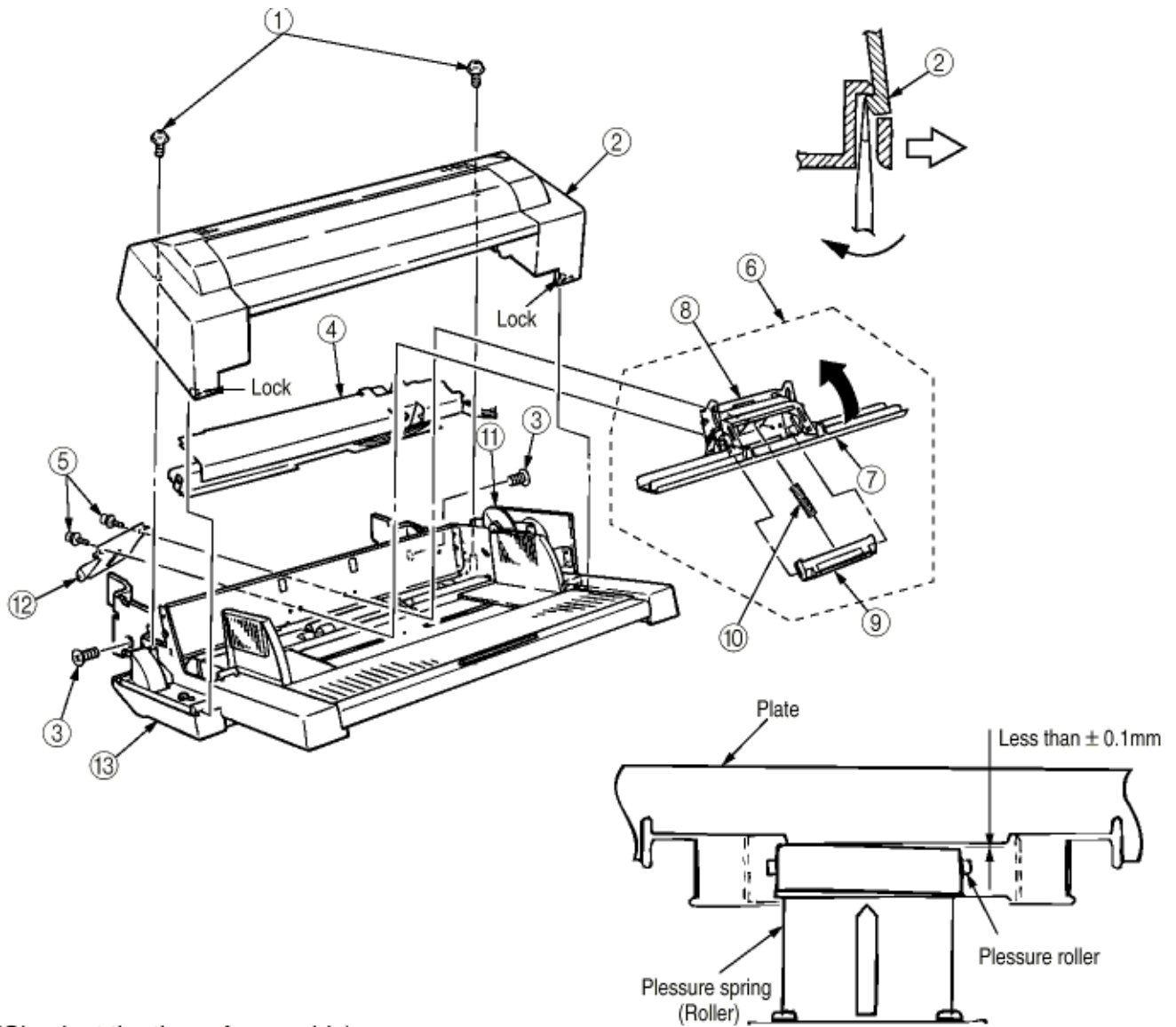

[Check at the time of assembly)



When the secondary stage of idle gear (11) is turned in the A direction after engaging the plate and the frame, the inclination of the pressure roller (12) is less than ± 0.1 mm against the plate (13), as shown in the right figure. When the inclination of the pressure roller exceeds ± 0.1 mm, fine-adjust it by pressing with fingers, as shown in the left figure, with the pressure spring (roller) installed.

3.3.2 AOLE-PCB

- (1) Remove the upper cover (see 3.1.1 (1) to (3)).
- (2) Remove two screws (1) and remove the AOLE-PCB (2).
- (3) Remove the connector (3).
- (4) Remove the connector (4).

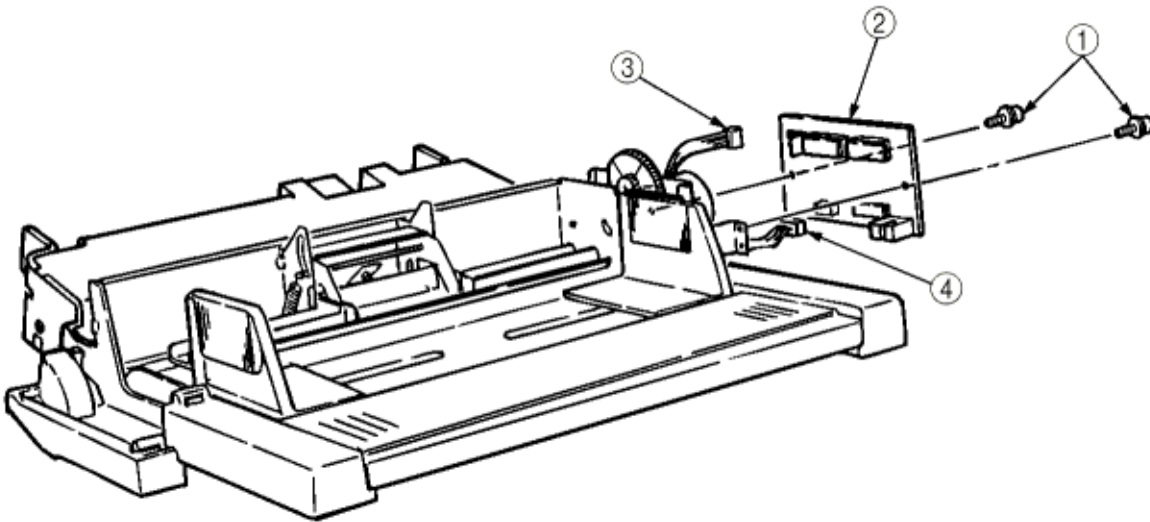

Caution: Be careful to set the sensor plate properly when mounting AOLE-PCB.

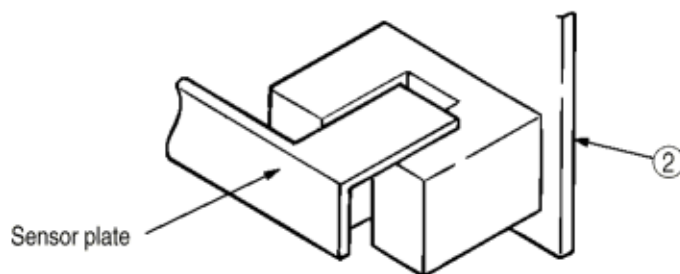

3.3.3 Square-shaped connector

- (1) Remove the upper cover and remove the cover frame (5) (see 3.3.1 (1) to (4)).
- (2) Remove the AOLE-PCB (see 3.3.2).
- (3) Remove the screw (1) and remove the square-shaped connector (2).
- (4) Using the connector remover, remove the nylon cord (3) from the square-shaped connector (2).

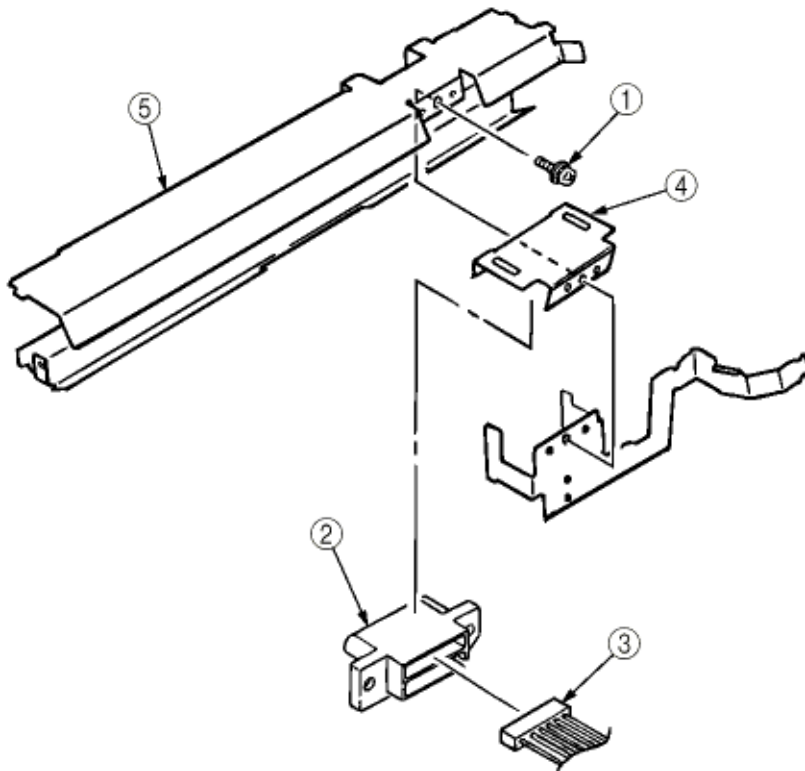

[Confirmation after assembly]

1. The square connector (2) should be horizontal to the cover frame (5).

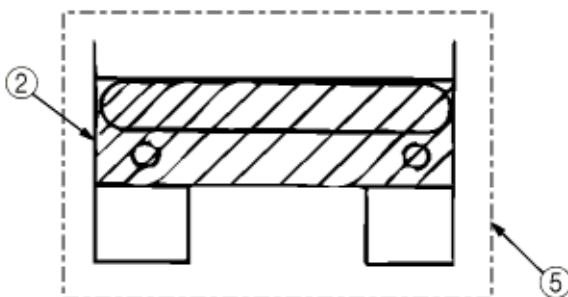

2. The square connector (2) should be hooked on the connector spring (4) and move smoothly.

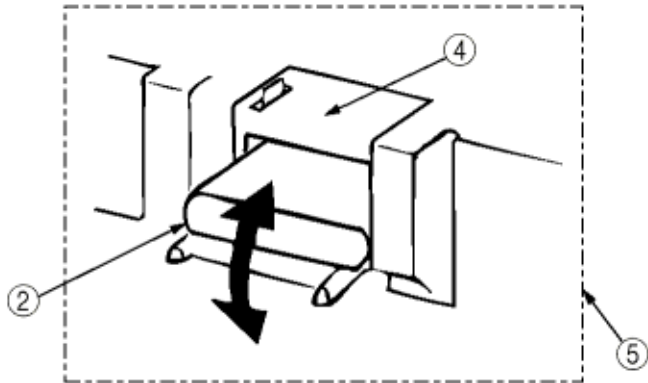

Copyright 1998, Okidata, Division of OKI America, Inc. All rights reserved. See the OKIDATA Business Partner Exchange (BPX) for any updates to this material. (<http://bpx.okidata.com>)

Service Guide OKIPAGE 18/18n

Chapter E Multi-Purpose Feeder Maintenance

3.3.4 Hopping Motor

- (1) Remove the upper cover (see 3.3.1 (1) to (3)).
- (2) Remove the AOLE-PCB. (see 3.3.2).
- (3) Remove two screws (1), then remove the hopping motor (2).

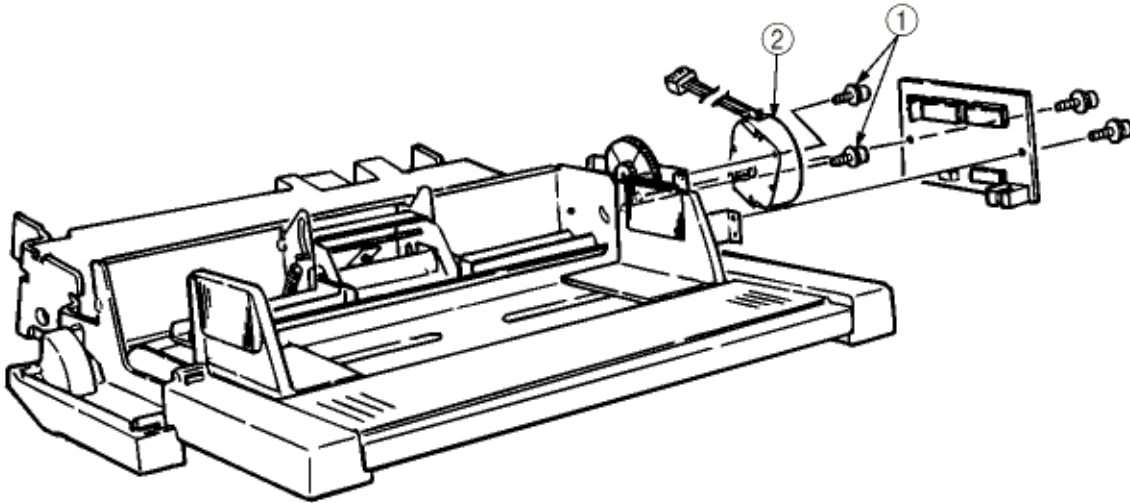

Service Guide OKIPAGE 18/18n

Chapter E Multi-Purpose Feeder Maintenance

3.3.5 Planet gear

- (1) Remove the upper cover (see 3.3.1 (1) to (3)).
- (2) Remove the AOLE-PCB (see 3.3.2).
- (3) Remove two screws (1), then remove the motor bracket assy (2) and the planet gear (3).

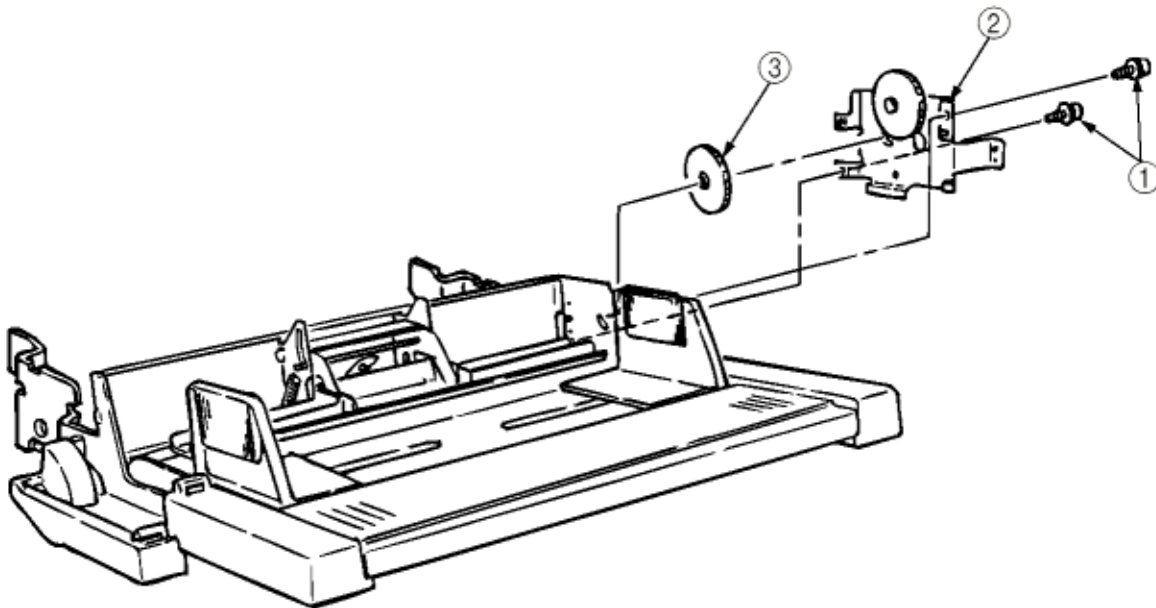



Service Guide OKIPAGE 18/18n

Chapter E Multi-Purpose Feeder Maintenance

3.3.6 Roller B

- (1) Remove the upper cover (see 3.3.1 (1) to (3)).
- (2) Disengage the plate and frame (on both sides).
- (3) Remove the separator assy (see 3.3.1 (1) to (3)).
- (4) Remove the AOLE-PCB (see 3.3.2).
- (5) Remove the motor bracket assy (see 3.3.5).
- (6) Remove the gear (1).
- (7) Shift the roller B (2) to the right, lift it by holding on its left side, and pull it out to the left side. The bearing (3) also comes off at the same time, so be careful not to lose it. Further, pay special attention to make sure that you do not damage the sensor lever (4) while going through this procedure.

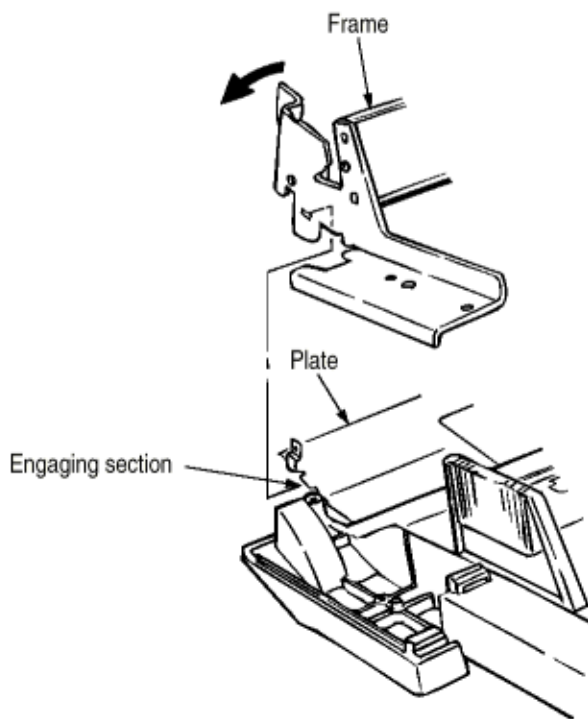
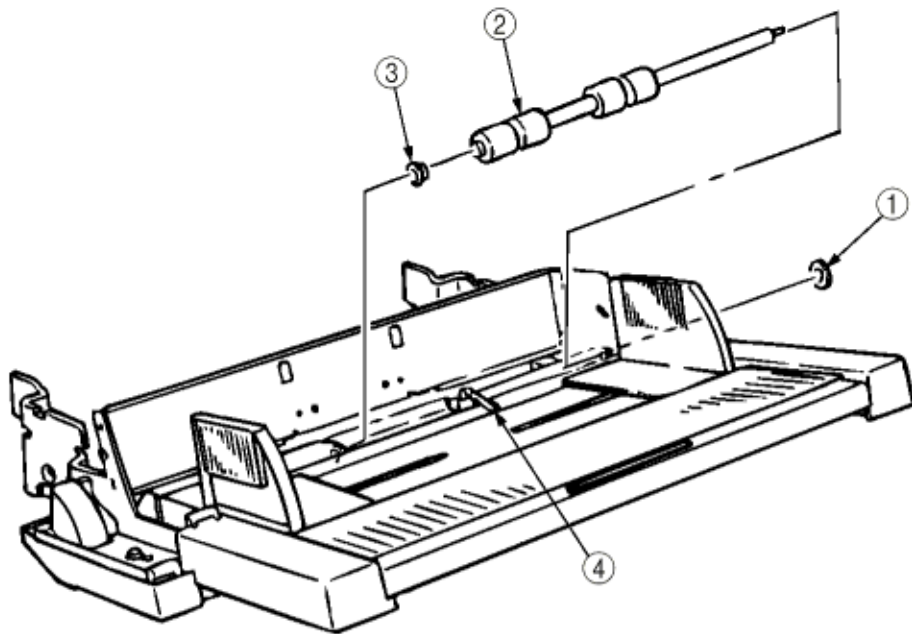



Service Guide OKIPAGE 18/18n
Chapter E Multi-Purpose Feeder Maintenance

3.3.7 Roller A

- (1) Remove the motor bracket assy (see 3.3.5).
- (2) Remove two gears (1) and then another gear (2).
- (3) Disengage the plate (3) and the frame (4).
- (4) Remove four screws (5) and remove the frame (4) (see 3.3.6).
- (5) Move the belt to the right and remove it from the one-way pulley (6).
- (6) Move the carrier roller assembly to the right, and remove it from the shaft (7).
- (7) Move the roller A (8) to the right, lift its left side, and then pull it off to the left. (Be careful not to lose the shaft (7) being removed together).

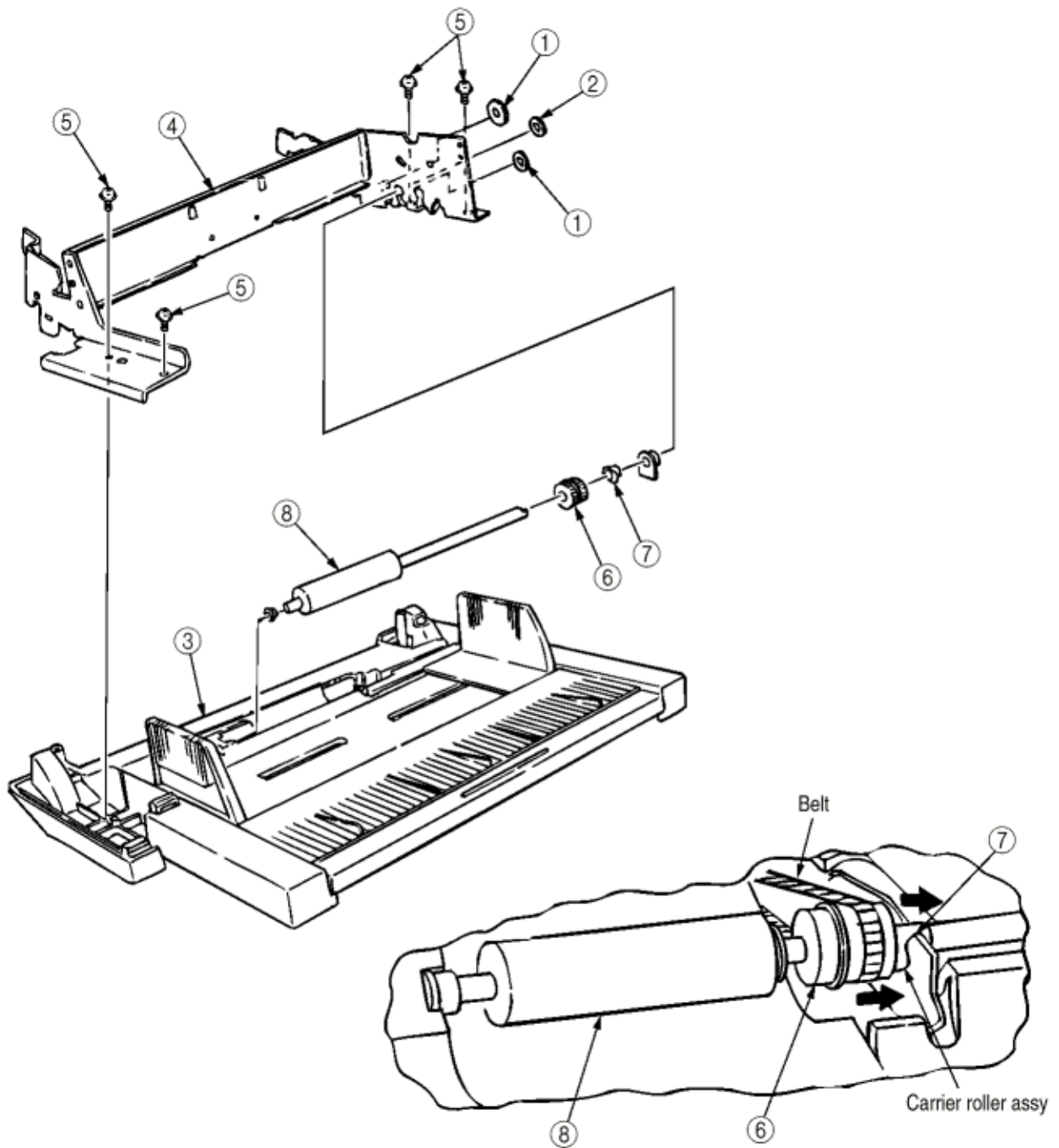

Copyright 1998, Okidata, Division of OKI America, Inc. All rights reserved. See the OKIDATA Business Partner Exchange (BPX) for any updates to this material. (<http://bpx.okidata.com>)



Service Guide OKIPAGE 18/18n
Chapter E Multi-Purpose Feeder Maintenance

3.3.8 Mini pitch belt & Feed roller

- (1) Remove the roller A (see 3.3.7).
- (2) Remove the bearing (1) and remove the feed roller assy (2).
- (3) Remove two bearings (3) and remove the plate (4).
- (4) Remove the mini pitch belt (5) and the feed roller (6).

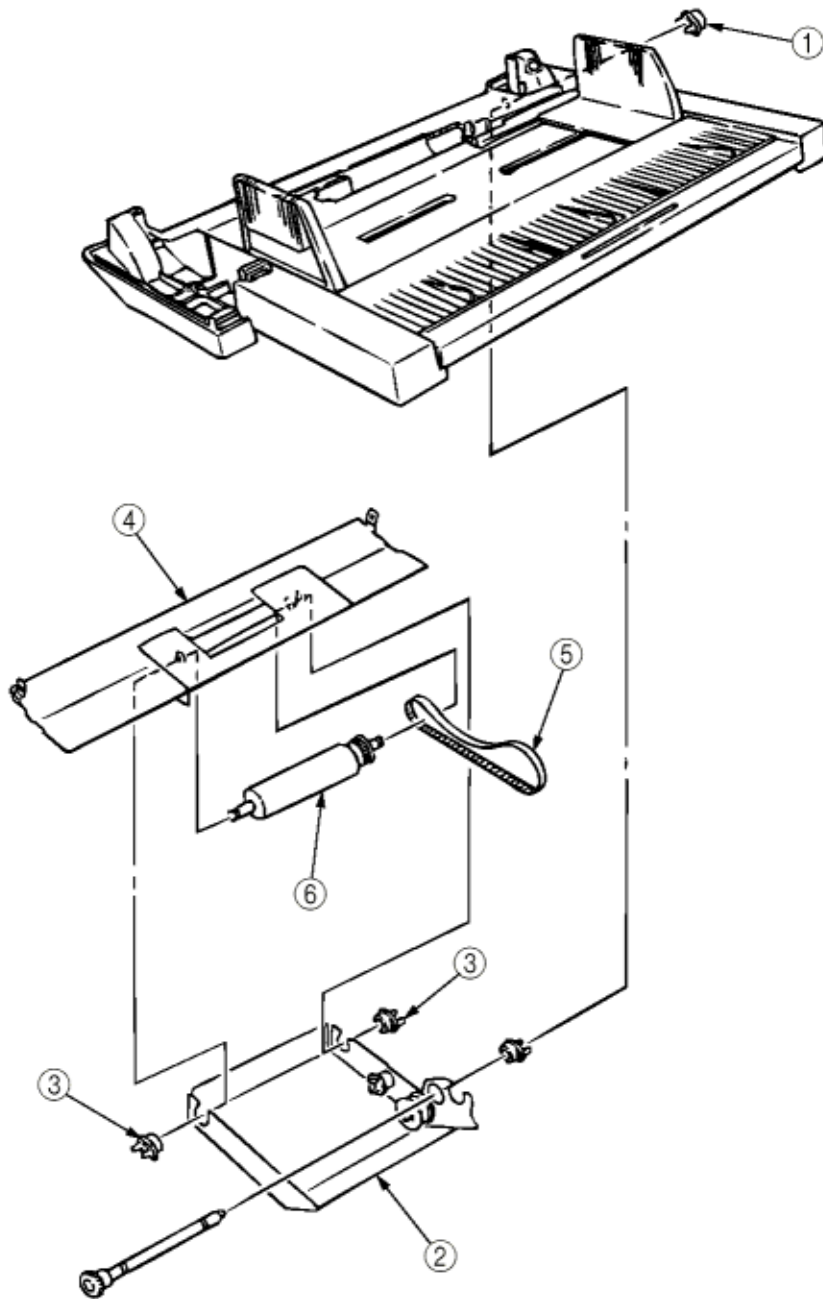

Copyright 1998, Okidata, Division of OKI America, Inc. All rights reserved. See the OKIDATA Business Partner Exchange (BPX) for any updates to this material. (<http://bpx.okidata.com>)



Service Guide OKIPAGE 18/18n
Chapter E Multi-Purpose Feeder Maintenance

4.0 Troubleshooting

Precautions Prior to the Troubleshooting

Preparations for the Troubleshooting

Troubleshooting Method

Copyright 1998, Okidata, Division of OKI America, Inc. All rights reserved. See the OKIDATA Business Partner Exchange (BPX) for any updates to this material. (<http://bpx.okidata.com>)



Service Guide OKIPAGE 18/18n
Chapter E Multi-Purpose Feeder Maintenance

4.1 Precautions Prior to the Troubleshooting

- (1) Go through the basic checking items provided in the Operator Guide.
 - (2) Obtain detailed information concerning the problem from the user.
 - (3) Go through the checking in the conditions similar to that in which the problem occurred.
-

Copyright 1998, Okidata, Division of OKI America, Inc. All rights reserved. See the OKIDATA Business Partner Exchange (BPX) for any updates to this material. (<http://bpx.okidata.com>)



Service Guide OKIPAGE 18/18n

Chapter E Multi-Purpose Feeder Maintenance

4.2 Preparations for the Troubleshooting

(1) Display on the operator panel

The status of the problem is displayed on the LCD (Liquid Crystal Display) on the operator panel. Go through the appropriate troubleshooting procedures according to the messages displayed on the LCD.

Copyright 1998, Okidata, Division of OKI America, Inc. All rights reserved. See the OKIDATA Business Partner Exchange (BPX) for any updates to this material. (<http://bpx.okidata.com>)



Service Guide OKIPAGE 18/18n

Chapter E Multi-Purpose Feeder Maintenance

4.3 Troubleshooting Method

When a problem occurs, go through the troubleshooting according to the following procedure.

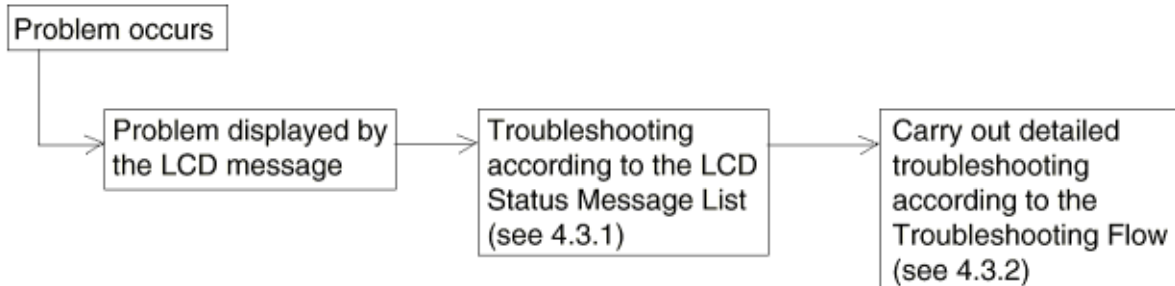

4.3.1 LCD Status Message List

4.3.2 Troubleshooting Flow



Service Guide OKIPAGE 18/18n

Chapter E Multi-Purpose Feeder Maintenance

4.3.1 LCD Status Message List

The listing of the statuses and problems displayed in the form of messages on the LCD is provided in Table 4-1.

Classification	LCD Status Message	Description	Recover Method
Jam Error	<div style="border: 1px solid black; padding: 2px;">PAPER INPUT JAM CHECK FEEDER</div> <div style="border: 1px solid black; padding: 2px; margin-top: 5px;">PAPER FEED JAM CHECK FEEDER</div>	Notifies of occurrence of jam while the paper is being fed from the Multi-Feeder.	<ul style="list-style-type: none">- Check the paper in the Multi-Feeder. Carry out the recover printing by opening the cover, removing jammed paper and closing the cover, and then turning the error display off.- When the problem occurs frequently, go through the Troubleshooting.
Paper size error	<div style="border: 1px solid black; padding: 2px;">ERROR PAPER SIZE CHECK FEEDER</div>	Notifies of incorrect size paper feeding from the Multi-Feeder.	<ul style="list-style-type: none">- Check the paper in the Multi-Feeder. Also check to see if there was a feeding of multiple sheets. Carry out the recovery printing by opening the cover, and then turning the error display off.
Tray paper out	<div style="border: 1px solid black; padding: 2px;">PAPER OUT mmmmmmmm FEEDER</div> <p>mmmmmmmm: Paper size in the tray being selected</p>	Notifies of no paper state of the Multi-Feeder.	<ul style="list-style-type: none">- Load the paper in the Multi-Feeder.
Interface Timeout	<div style="border: 1px solid black; padding: 2px;">PAPER OUT mmmmmmmm FEEDER</div>	Notifies of occurrence of interface timeout between the printer and the Multi-Feeder.	<ul style="list-style-type: none">- Verify connection of AOLE-PCB and square-shaped connector. Replace the square-shaped connector if necessary.- Replace AOLE-PCB.



4.3.2 Troubleshooting Flow

- (JAM error)

Paper Input Jam

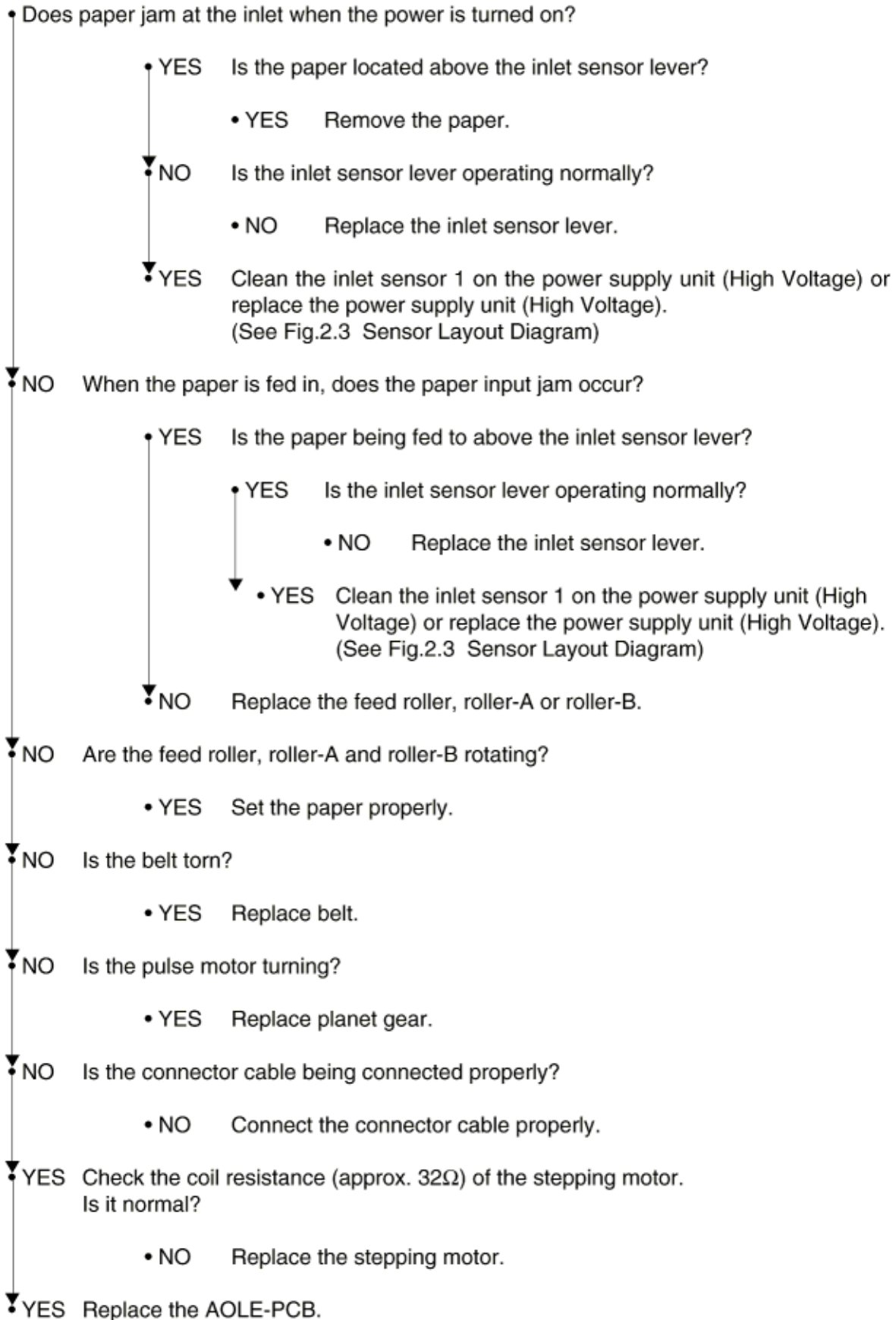

Copyright 1998, Okidata, Division of OKI America, Inc. All rights reserved. See the OKIDATA Business Partner Exchange (BPX) for any updates to this material. (<http://bpx.okidata.com>)



Service Guide OKIPAGE 18/18n
Chapter E Multi-Purpose Feeder Maintenance

5.0 Connection Diagram

5.1 Interconnection Diagram

5.2 PCB Layout

Copyright 1998, Okidata, Division of OKI America, Inc. All rights reserved. See the OKIDATA Business Partner Exchange (BPX) for any updates to this material. (<http://bpx.okidata.com>)

Service Guide OKIPAGE 18/18n Chapter E Multi-Purpose Feeder Maintenance

5.1 Interconnection Diagram

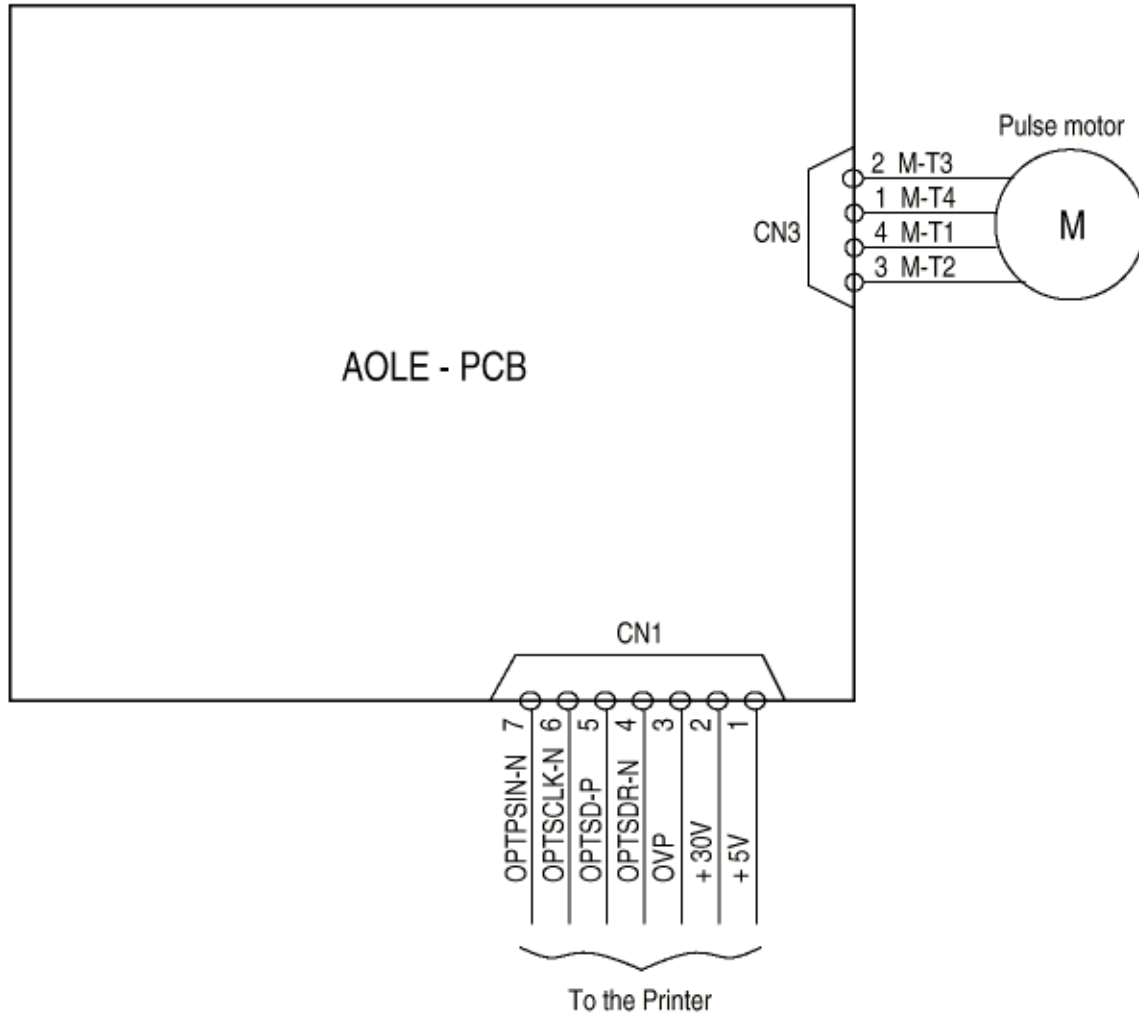

Service Guide OKIPAGE 18/18n Chapter E Multi-Purpose Feeder Maintenance

5.2 PCB Layout

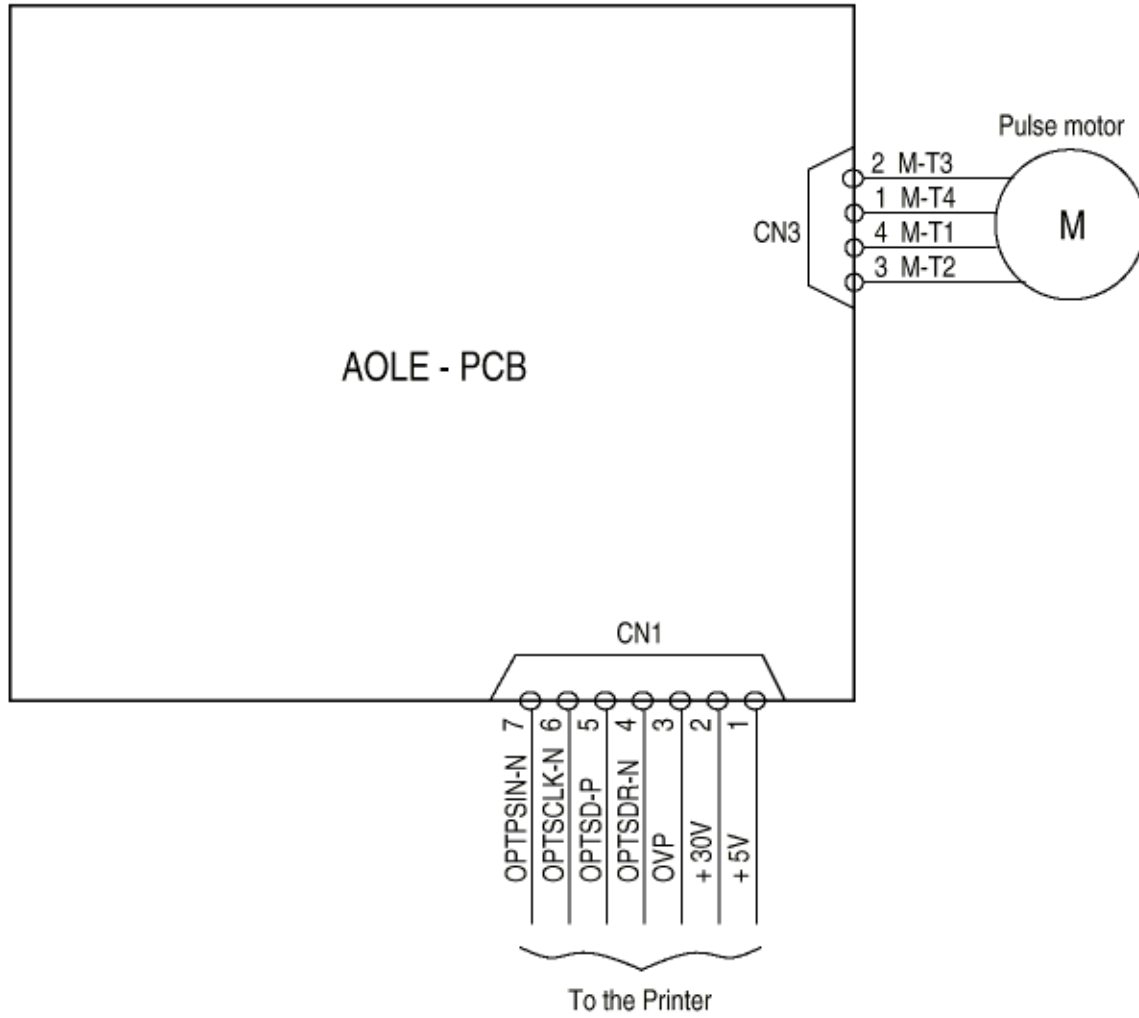

AOLE-PCB

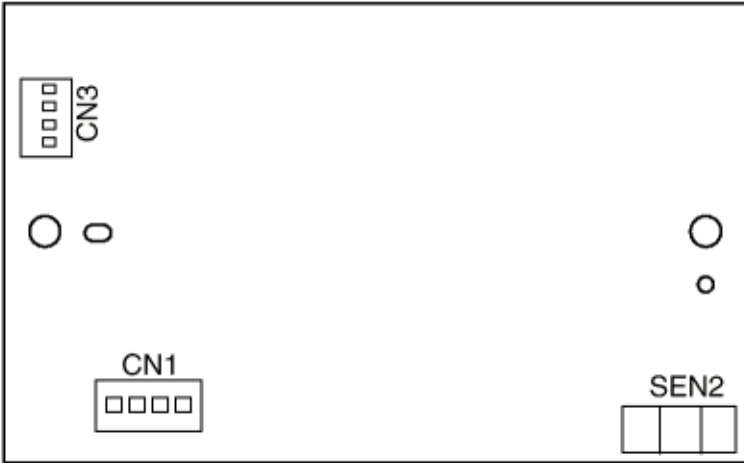

Copyright 1998, Okidata, Division of OKI America, Inc. All rights reserved. See the OKIDATA Business Partner Exchange (BPX) for any updates to this material. (<http://bpx.okidata.com>)



Service Guide OKIPAGE 18/18n
Chapter E Multi-Purpose Feeder Maintenance

6.0 Parts List

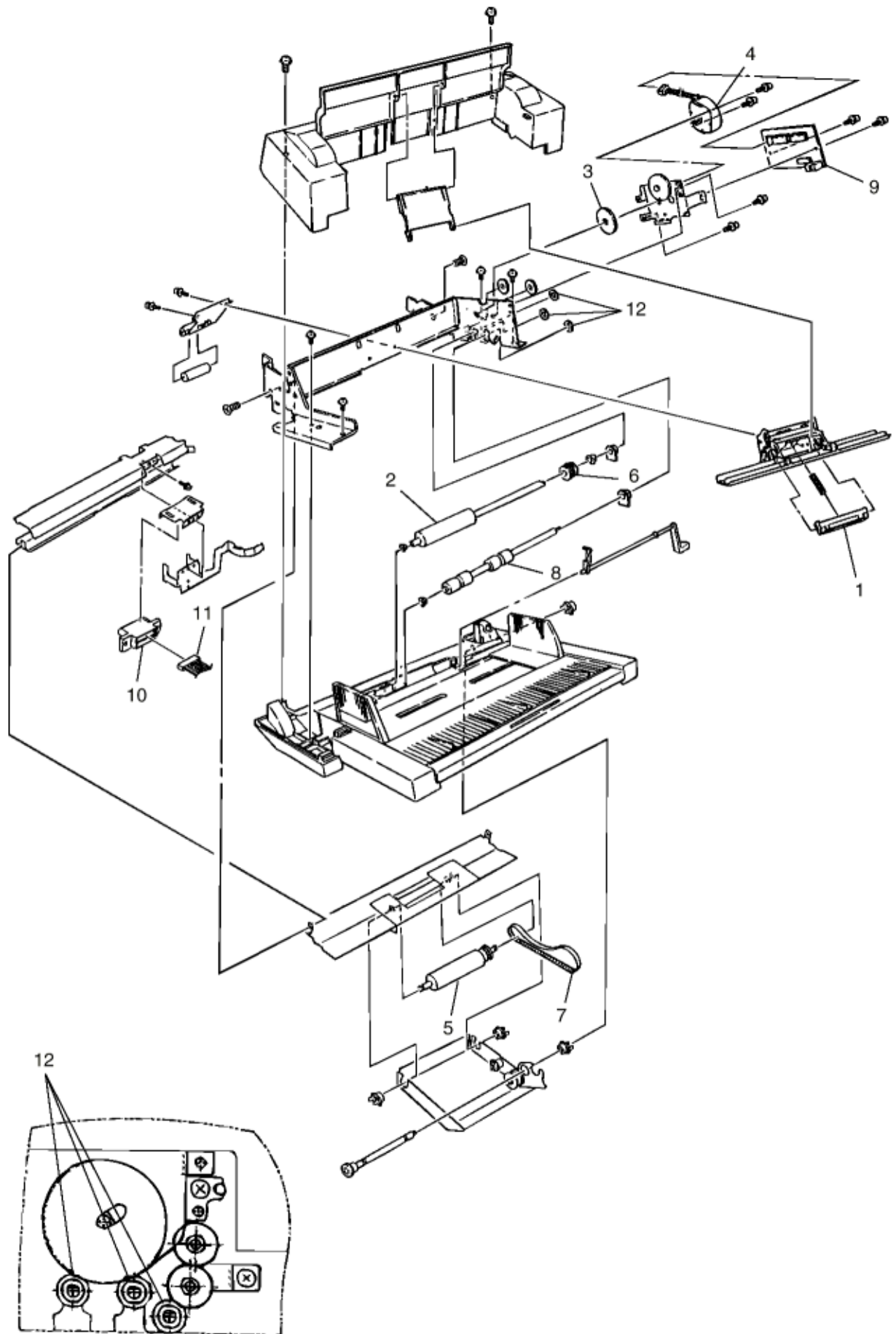

Table 6-1 Multi-Feeder

No.	Part No.	Name	Qty	Recommended Qty			Remarks
				50	100	1000	
1	53344201	Separator	1	1	3	6	
2	53343801	Roller-A	1	1	3	6	
3	51229601	Planet gear	1	1	3	6	
4	56510701	Hopping motor	1	1	3	6	
5	50409701	Roller - C	1	1	3	6	
6	51235701	One-way pulley	1	1	3	6	
7	51304901	Mini pitch belt	1	1	3	6	
8	53343901	Roller - B	1	1	3	6	
9	55077601	AOLE-PCB	1	1	3	6	
10	56731641	Connector (IMSA-9714N-14B)	1	0	3	6	
11	56730804	Nylon connector cord	1	0	3	6	
12	51239301	Stirrer roller gear	3	3	9	18	

Copyright 1998, Okidata, Division of OKI America, Inc. All rights reserved. See the OKIDATA Business Partner Exchange (BPX) for any updates to this material. (<http://bpx.okidata.com>)